



February 20, 2013

Secretary of the Commission
Indiana Utility Regulatory Commission
National City Center
101 West Washington Street, Suite 1500 East
Indianapolis, Indiana 46204

Dear Secretary:

Pursuant to 170 IAC 1-6 ("Rule 6"), the Thirty-Day Administrative Filing Procedures and Guidelines Rules, Indianapolis Power & Light Company ("IPL") submits herewith for approval a Power Purchase Agreement for Qualifying Renewable Energy Power Production Facilities between 5585 LP and IPL dated February 19, 2013 ("Agreement").

Specifically 170 IAC 1-6 Section 3(6) allows for the filing of this contract as a "filing for which the commission has already approved or accepted the procedure for the change." The Commission approved IPL's Rate REP – Renewable Energy Production in its Order dated February 10, 2010 in Cause No. 43623 (Phase I) and ordered (at 62) that "[a]ny long-term contracts between IPL and its customers wishing to sell renewable energy under Rate REP shall be submitted to the Commission for approval utilizing the 30-day filing process."

Rate REP – Renewable Energy Production, the Commission-approved tariff under which the Agreement was entered, was created so that customers may alternatively choose to participate in a renewable energy feed-in rate for generation resources with capacity ratings ranging from 50 kW (20 kW for solar) to 10 MW. Rate REP provides pricing unique to the type of renewable energy produced and allows for long-term contracting. In its Order dated March 7, 2012 in Cause No. 44018, the Commission approved further changes to Rate REP with which this agreement complies.

In support of this 30-day filing IPL is submitting herewith (1) a copy of the Commission-approved Rate REP – Renewable Energy Production, I.U.R.C. No. E-16, 1st Revised No. 124, 124.1, 124.2 and 124.3; (2) a verified statement by the Company affirming that customers have been notified as required under Rule 6, stating in detail the means used for notification, and copies of any written means of notification; (3) a copy of the publisher's affidavit; and (4) a copy of the Power Purchase Agreement. By copy of this letter, the Office of Utility Consumer Counselor is being provided with a copy of this 30-day filing.

Received On: February 20, 2013

IURC 30-DAY Filing No.: 3125

Indiana Utility Regulatory Commission

February 20, 2013

Page 2

IPL appreciates your assistance in processing this request through the Commission's 30-Day Filing procedures. The contact information regarding this filing is as follows:

John E. Haselden, P.E.
Indianapolis Power & Light Company
One Monument Circle
Indianapolis, Indiana 46204
Phone: 317-261-6629
Fax: 317-261-5867
Email: john.haselden@aes.com

Sincerely,

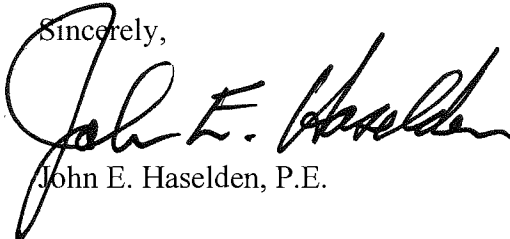

John E. Haselden, P.E.

Enclosures

cc: A. David Stippler, Office of Utility Consumer Counselor – w/enclosures via email

**POWER PURCHASE AGREEMENT
FOR QUALIFYING RENEWABLE ENERGY POWER PRODUCTION FACILITIES**

THIS POWER PURCHASE AGREEMENT FOR QUALIFYING RENEWABLE ENERGY POWER PRODUCTION FACILITIES (“Agreement”) is made and entered into this 19th day of February, 2013 (“Effective Date”), by and between Indianapolis Power & Light Company, an Indiana corporation with its principal office located at One Monument Circle, Indianapolis, Indiana 46204 (“Buyer”), and 5855, LP, an Indiana limited partnership with its principal office located at 338 South Arlington Avenue, Suite 202, Indianapolis, IN 46219 (“Seller”). Buyer and Seller are hereinafter sometimes referred to individually as “Party” or collectively as “Parties”.

WITNESSETH:

WHEREAS, Seller desires to Sell renewable electric power inclusive of all rights to its attendant Environmental Attributes and the Buyer desires to purchase the same and recover such costs for retail ratemaking through the authority granted by the IURC, and

WHEREAS, Seller is installing, or has installed a Facility, to be interconnected with and operated in parallel with Buyer’s electric system, which Facility is more fully described in Exhibit A, attached hereto and incorporated herein by this Agreement, and as follows:

Location: 5855 E. Washington St., Indianapolis, IN 46219

Nameplate Capacity: 77.7 kW (AC)

Estimated Annual Production: 101,560 kWh

Type of Qualifying Technology: Solar Photovoltaic

NOW, THEREFORE, in consideration thereof, Buyer and Seller agree as follows:

1. Definitions.

1.1 In addition to other terms specifically defined elsewhere in the Agreement, where capitalized, the following words and phrases shall be defined as follows:

- (a) “Applicable Law” means, with respect to any Person, any constitutional provision, law, statute, rule, regulation, ordinance, treaty, order, decree, judgment, decision, certificate, holding, injunction, registration, license, franchise, permit, authorization, guideline, Governmental Approval, consent or requirement of any Governmental Authority having jurisdiction over such Person or its property, enforceable at law or in equity, including the interpretation and administration thereof by such Governmental Authority.

- (b) “Assignment” has the meaning set forth in Section 11.
- (c) “Bankrupt” means with respect to any entity, such entity (i) files a petition or otherwise commences, authorizes or acquiesces in the commencement of a proceeding or cause of action under any bankruptcy, insolvency, reorganization or similar law, or has any such petition filed or commenced against it, (ii) makes an assignment or any general arrangement for the benefit of creditors, (iii) otherwise becomes bankrupt or insolvent (however evidenced), (iv) has a liquidator, administrator, receiver, trustee, conservator or similar official appointed with respect to it or any substantial portion of its property or assets, or (v) is generally unable to pay its debts as they fall due.
- (d) “Business Day” means any day other than Saturday, Sunday or any other day on which banking institutions in Indiana are required or authorized by Applicable Law to be closed for business.
- (e) “Commercial Operation Date” means the date on which testing in accordance with such methods, acts, guidelines, standards and criteria reasonably accepted or followed by the majority of photovoltaic system integrators in the United States indicate that the System is capable of generating electric energy for four (4) continuous hours, using such instruments and meters as have been installed for such purposes, and the interconnection to the Buyer’s electric grid and all review and approvals have been provided by the applicable utility and the State of Indiana.
- (f) “Commercially Reasonable Efforts” means, with respect to any action required to be made, attempted or taken by a Party under this Agreement, the level of effort in light of the facts known to such Party at the time a decision is made that: (a) can reasonably be expected to accomplish the desired action at a reasonable cost; (b) is consistent with Good Electric Industry Practices; and (c) takes into consideration the amount of advance notice required to take such action, the duration and type of action and the competitive environment in which such action occurs.
- (g) “Delivery Point” means the point at the point of interconnection as defined in the Interconnection Agreement.
- (h) “Environmental Attributes” have the meaning set forth in Rate REP of the Rates and Charges.
- (i) “Facility” means the Qualifying Renewable Energy Power Production Facility described in Exhibit A.
- (j) “Financing Party” means as applicable (i) any person (or its agent) from whom Seller leases the Facility or (ii) any person (or its agent) who has made or will make a loan to or otherwise provide capital to Seller with respect to the Facility.

- (k) "Force Majeure" means any cause or event not reasonably within the control of the Party claiming Force Majeure, including, but not limited to, the following: acts of God, strikes, lockouts, or other industrial disturbances; acts of public enemies; orders or permits or the absence of the necessary orders or permits of any kind which have been properly applied for from the government of the United States, the State of Indiana, any political subdivision or municipal subdivision or any of their departments, agencies or officials, or any civil or military authority; unavailability of material used in connection with the construction and operation of the Facility; extraordinary delay in transportation; unforeseen soil conditions; equipment, material, supplies, labor or machinery shortages; epidemics; landslides; lightning; earthquakes; fires; hurricanes; tornadoes; storms; floods; washouts; drought; arrest; war; civil disturbances; explosions; breakage or accident to machinery, transmission lines, pipes or canals; partial or entire failure of utilities; breach of contract by any supplier, contractor, subcontractor, laborer or materialman; sabotage; injunction; blight; famine; blockade; or quarantine.
- (l) "Good Electric Industry Practices" means the practices, methods, standards and acts engaged in or approved by a significant portion of the independent electric power generation industry pertaining to solar photovoltaic energy facilities of the type, similar size and location to the Facility that, at a particular time, in the exercise of reasonable judgment, in light of the facts that are known, or reasonably should have been known, at the time a decision was made, would have been expected to accomplish the desired result in a manner consistent with law, regulation, permits, codes, standards, equipment manufacturer's recommendations, reliability, safety, environmental protection, economy, and expedition. For purposes of this Agreement, Good Electric Industry Practices is not intended to be limited to the optimum practice, method, standard or act to the exclusion of all others, but rather to those practices, methods, standards and acts generally acceptable or approved by a significant portion of the independent electric power generation industry for solar energy facilities in the relevant region, during the relevant period, as described in the immediate preceding sentence.
- (m) "Governmental Approval" means any approval, consent, franchise, permit, certificate, resolution, concession, license, or authorization issued by or on behalf of any applicable Governmental Authority.
- (n) "Governmental Authority" means any federal, state, regional, county, town, city, or municipal government, whether domestic or foreign, or any department, agency, bureau, or other administrative, regulatory or judicial body of any such government.
- (o) "IURC" means the Indiana Utility Regulatory Commission.

- (p) “Losses” means all losses, liabilities, claims, demands, suits, causes of action, judgments, awards, damages, cleanup and remedial obligations, interest, fines, fees, penalties, costs and expenses (including all reasonable attorneys’ fees and other costs and expenses incurred in defending any such claims or other matters or in asserting or enforcing any indemnity obligation).
- (q) “Person” means an individual, partnership, corporation, limited liability company, business trust, joint stock company, trust, unincorporated association, joint venture, firm, or other entity, or a Governmental Authority.
- (r) “Rates and Charges” means Buyer’s I.U.R.C. No. E-16 tariff on file with the IURC, as amended from time to time, or its successor.
- (s) “Sale” or “Sell” has the meaning of the word Sale set forth in Rate REP of the Rates and Charges.
- (t) “Stated Rate” means a rate per annum equal to the lesser of (a) the “prime rate” (as reported in The Wall Street Journal) plus one percent (1%) and (b) the maximum rate allowed by Applicable Law.
- (u) “System Emergency” means a condition on the Buyer's system which is liable to result in imminent significant disruption of service to Customers or in substantial deviation from normal service standards or which is imminently liable to endanger life or property.
- (v) “Term” has the meaning set forth in Section 10.1

2. Purchase.

Buyer agrees to purchase from Seller and Seller agrees to Sell to Buyer all of the energy, capacity and Environmental Attributes produced by the Facility during the Term of this Agreement except in the event of a Force Majeure or the Facility being disconnected or isolated from Seller’s system pursuant to the Interconnection Agreement. Energy required by the Seller to operate the Facility may be purchased from the Buyer pursuant to its then effective IURC Rates and Charges and shall not be addressed by this Agreement.

3. Tariff.

This Agreement is entered into subject to the terms of Buyer’s Rate REP as set forth in the Rates and Charges which are incorporated herein by reference.

4. Interconnection.

4.1 Interconnection Agreement. Seller and Buyer have entered into an Interconnection Agreement providing for the interconnection of the Facility to Buyer’s electrical system, a copy of which is attached hereto as Exhibit A.

4.2 Facility Operation Consistent with Interconnection Agreement. Any changes in Facility operations that necessitate changes in Buyer's operations must be approved prior to implementation and Seller must pay for any required improvements to Buyer's system. The Seller shall install, operate, and maintain in good order such relays, locks and seals, breakers, automatic synchronizer, and other control and protective apparatus as shall be designated by the Buyer for operation parallel to its system consistent with the Interconnection Agreement. The Seller shall bear full responsibility for the installation and safe operation of this equipment. Breakers capable of isolating the Facility from the Buyer shall at all times be immediately accessible to the Buyer. The Buyer may isolate or disconnect the Facility, and shall have no obligation to purchase energy or capacity from the Facility at its own discretion if the Buyer reasonably believes continued parallel operation with the Facility creates or contributes to a System Emergency, causes damage to Buyer's system or to Buyer's customers connected to its system or for other reasons stated in Section 4 of the Interconnection Agreement. Seller agrees that, without the prior written permission from Buyer, no changes shall be made to the configuration of the Facility, as that configuration is described in Exhibit A, and no relay or other control or protection settings specified in Exhibit A shall be set, reset, adjusted or tampered with, except to the extent necessary to verify that the Facility complies with Buyer approved settings. In the event Seller changes the configuration of the Facility without Seller's prior, written consent, Buyer may suspend purchases from the Facility without obligation to pay for any energy, capacity or Environmental Attributes during the suspension until Seller demonstrates to Buyer the Facility's configuration is consistent with Exhibit A.

4.3 Metering of Energy. To properly record numbers of kilowatt-hours for, respectively, purchase and Sale, the following configurations shall be the basis for metering:

- (a) Where such measurement is appropriate for measurement of energy, the circuit shall include at minimum one monodirectional meter between, at one side, the Buyer's system and, on the other side, the load and a bidirectional meter between, at one side, the Buyer's system and on the other side, the Facility and any load associated with it;
- (b) Where such measurement is appropriate for measurement of energy, the circuit shall include a monodirectional meter between the on-site load and the Buyer and, in a series arrangement, two monodirectional meters between the Facility and the Buyer's system;
- (c) The meter measuring purchases by the Buyer shall be of a design to record time periods, and shall be capable of electronically transmitting instantaneous readings; or
- (d) Other metering arrangements shall be the subject of negotiations between the Buyer and the Seller.

5. IURC JURISDICTION

5.1 Buyer is subject to the jurisdiction of the IURC. The Buyer shall seek approval of this Agreement via the IURC's 30-day administrative filing process to recognize the costs of

power purchased pursuant to this Agreement for retail ratemaking purposes pursuant to Ind. Code § 8-1-8.8-1 et. seq. This Agreement will be void if the IURC does not approve the recovery of costs imposed by the Agreement on Buyer through retail rates.

6. WHOLESALE POWER SALES

Seller represents that it has or will obtain prior to making wholesale power sales the necessary authority to make wholesale sales of power to Buyer pursuant to the Federal Power Act or other applicable law prior to the Commercial Operation Date.

7. PRICE AND PAYMENT

7.1 Rates For Purchase. The rate the Buyer will pay the Seller for energy and capacity generated by the Facility shall be \$0.24 per kilowatt hour during the Term of this Agreement. In consideration of the compensation, which is in excess of the avoided costs of traditional generation alternatives, IPL will retain all Environmental Attributes associated with the production of renewable energy by the Facility. The Buyer need not purchase or sell at a time of System Emergency or if the Facility is isolated or disconnected from Buyer's electric system pursuant to the Interconnection Agreement.

7.2 Title and Risk of Loss. Title and risk of loss to the energy shall pass from Seller to Buyer at the Delivery Point. Seller warrants that it will deliver to Buyer the energy and Environmental Attributes free and clear of all liens, security interests, claims and encumbrances or any interest therein or thereto by any person arising prior to the Delivery Point.

7.3 Billing. Buyer will read Seller's electric meter to determine the quantity of energy produced by the Facility each month. Buyer will remit payment and an invoice for energy purchased to Seller within two weeks after reading the meter.

7.4 Metering Devices. Buyer shall arrange to test the meter at least once per calendar year. Seller at its own expense, may require that Buyer initiate testing and inspection of the meter. Buyer shall permit a representative of Seller to witness and verify such inspections and tests. Buyer shall provide Seller with copies of any periodic or special inspection or testing reports relating to the meter. Buyer shall notify Seller within forty-eight (48) hours of Buyer receiving actual notice of any inaccuracy or defect in a meter. Buyer shall cause the meter to be adjusted, replaced, and/or recalibrated as near as practicable to a condition of zero (0) error at the expense of Buyer. Seller shall maintain, at its own expense, a back-up metering device which shall be inspected and tested at least annually at Seller's expense. Upon request by Buyer, the Seller shall perform additional inspections or tests of its back-up meter and shall permit a qualified representative of the requesting Party to inspect or witness the testing of such back-up meter. The actual expense of any requested additional inspection or testing of the back-up meter shall be borne by the Buyer. If either meter fails to register or is found upon testing to be inaccurate by more than a quarter of one percent (0.25%) the meter shall be readjusted. If such an inaccuracy is found with respect to the meter for which the reading was used for billing purposes, an adjustment shall be made correcting all measurements by the inaccurate or defective metering device, for both the amount of the inaccuracy and the period of the inaccuracy, in the following manner:

- (a) In the event that the meter is found to be defective or inaccurate and an adjustment factor for the meter cannot be reliably calculated, the Parties shall use the measurements from Seller's back-up meter.
- (b) If the back-up meter is not functioning or found to be inaccurate pursuant to the terms of this Section, the Parties shall use production data from Buyer's or Seller's computer monitoring system for the period of the inaccuracy and adjust that amount for historic line losses.
- (c) In the event that Seller's computer monitoring system is found to be materially inaccurate or is unavailable, the Parties shall look at relevant solar photovoltaic data and estimate what production would have been for the period for which inaccurate measurements were made.
- (d) In the event that the Parties cannot agree on the actual period during which the inaccurate measurements were made, the period during which the measurements are to be adjusted shall be the shorter of: (i) the last one-half (1/2) of the period from the last previous test of the meter to the test that found the meter to be defective or inaccurate; or (ii) the one hundred eighty (180) day period immediately preceding the test that found the meter to be defective or inaccurate.
- (e) To the extent that the adjustment period overlaps with a period of deliveries for which payment has already been made to Seller by Buyer, Buyer shall use the corrected measurements as determined in accordance with this Section to recalculate the amount due for the period of the inaccuracy and shall subtract the previous payments by Buyer for such period from such recalculated amount. If the difference is a positive number, the difference shall be paid by Buyer to Seller; if the difference is a negative number, that difference shall be paid by Seller to Buyer, or at Buyer's discretion such difference may take the form of an offset to payments due Seller by Buyer. Payment of such difference by the owing Party shall be made not later than thirty (30) days after the owing Party receives notice of the amount due, unless Buyer elects payment via an offset.

7.5 Disputed Payments. If a bona fide dispute arises with respect to any invoice or Buyer payment, Buyer shall not be deemed in default under the Agreement and the Parties shall not suspend the performance of their respective obligations hereunder, including payment of undisputed amounts owed hereunder. A Party may, in good faith, dispute the correctness of any invoice or any adjustment to an invoice, rendered under this Agreement or adjust any invoice for an arithmetic or computational error within twelve (12) months of the date of the invoice, or adjustment to an invoice, was rendered. In the event an invoice or portion thereof, or any other claim or adjustment arising hereunder, Buyer shall pay the undisputed portion of the invoice. Upon resolution of the dispute, any required payment shall be made within two business days of such resolution. Inadvertent overpayment shall be returned upon request or deducted by the Buyer from subsequent payments. Any dispute with respect to an invoice is waived unless the

other Party is notified in writing within twelve months after the invoice is rendered or any specific adjustment to the invoice is made. If an amount disputed by Buyer is subsequently deemed to have been due pursuant to the applicable invoice, interest shall accrue at the Stated Rate on such amount from the date becoming past due under such invoice until the date paid.

7.6 Netting. If Seller has failed to pay any amount due to Buyer under any other agreement between the parties (the "Indebtedness"), Buyer may net such Indebtedness of any payments owed to Seller under this Agreement.

7.7 Governmental Charges. Seller shall pay or cause to be paid all taxes imposed by any Governmental Authority ("Governmental Charges") on or with respect to the energy arising prior to the Delivery Point. Buyer shall pay or cause to be paid all Governmental Charges with respect to the energy at and from the Delivery Point (other than ad valorem, franchise or income taxes which are related to the sale of the energy and are, therefore, the responsibility of the Seller).

8. REPRESENTATIONS AND WARRANTIES

8.1 Representations and Warranties Relating to Agreement Validity. In addition to any other representations and warranties contained in the Agreement, each Party represents and warrants to the other as of the Effective Date that:

- (a) it is duly organized and validly existing and in good standing in the jurisdiction of its organization;
- (b) it has the full right and authority to enter into, execute, deliver, and perform its obligations under the Agreement;
- (c) it has taken all requisite corporate or other action to approve the execution, delivery, and performance of the Agreement;
- (d) the Agreement constitutes its legal, valid and binding obligation enforceable against such Party in accordance with its terms, except as may be limited by applicable bankruptcy, insolvency, reorganization, moratorium, and other similar laws now or hereafter in effect relating to creditors' rights generally;
- (e) there is no litigation, action, proceeding or investigation pending or, to the best of its knowledge, threatened before any court or other Governmental Authority by, against, affecting or involving any of its business or assets that could reasonably be expected to adversely affect its ability to carry out the transactions contemplated herein;
- (f) its execution and performance of the Agreement and the transactions contemplated hereby do not constitute a breach of any term or provision of, or a default under, (i) any contract or agreement to which it is a party or by which its property is bound, (ii) its organizational documents, or (iii) any Applicable Laws;

- (g) it is an entity with the legal capacity to sue and to be sued, and does not have immunity under any Applicable Law from any legal action, suit or proceeding brought in connection with the performance or enforcement of its obligations under the Agreement, or collection of damages for any breach thereof; and
- (h) it has all the rights required to enter into the Agreement and perform its obligations hereunder without the consent of any third party, except for such third party consents that have already been obtained and that are in full force and effect, except to the extent approval of the IURC is required for the Buyer to take actions under this Agreement.

9. RELEASE AND INDEMNIFICATION.

9.1 Each Party (the "Indemnifying Party") shall release, indemnify and hold harmless the other Party from and against all claims, liability, damages and expenses, including attorney's fees, based on any injury to any person, including the loss of life, or damage to any property, including the loss of use thereof, arising out of, resulting from, or connected with, or that may be alleged to have arisen out of, resulted from, or connected with, an act or omission by the Indemnifying Party, its employees, agents, representatives, successors or assigns in the construction, ownership, operation or maintenance of the Indemnifying Party's facilities used in connection with this Agreement. Upon written request of the Party seeking relief under this Section 9, the Indemnifying Party shall defend any suit asserting a claim covered by this Section 9. If a Party is required to bring an action to enforce its rights under this Section 9, either as a separate action or in connection with another action, and said rights are upheld, the Indemnifying Party shall reimburse such Party for all expenses, including attorney's fees, incurred in connection with such action.

9.2 If an Indemnified Party determines that it is entitled to defense and indemnification under this Section 9, such Indemnified Party shall promptly notify the Indemnifying Party in writing of the Losses, and provide all reasonably necessary or useful information, and authority to settle and/or defend the Losses. Defense shall be provided by legal counsel of the Indemnified Party's choosing. No settlement that would impose costs or expense upon the Indemnified Party shall be made without such party's prior written consent.

10. TERM AND TERMINATION

10.1 Effective Term. This Agreement shall become effective after execution by both Parties and approval by the IURC pursuant to its 30-day filing procedure and shall continue in effect until terminated in accordance with the provisions of this Agreement. The Term of this Agreement shall be 15 years commencing with the date energy is first produced and transmitted to the Buyer.

10.2 Termination Resulting From Government Action. Buyer may terminate this Agreement if a non-appealable final act by a Governmental Authority with jurisdiction over Buyer renders the costs of power purchased hereunder unrecoverable from Buyer's retail customers; provided that during any appeal of such Governmental Authority action, Buyer will

not be required to incur any costs for the purchase of power from the Seller that are unrecoverable through retail rates. Termination by Buyer shall be effective immediately upon the costs becoming unrecoverable from Buyer's retail customers which shall occur automatically. Buyer will provide Seller written notice within five (5) Business Days of the effective date of the governmental action. In the event of a termination, Buyer shall have no further obligations to Seller and Seller shall have no claim for damages against Buyer for Losses. Buyer agrees to make available to Seller non-confidential information reasonably required by Seller in the event it chooses to defend the rate recovery of all costs associated with the purchase of electricity, capacity or Environmental Attributes under this Agreement; provided that Seller shall not make statements or imply in such defense that IPL is more than neutral as to its outcome.

10.3 Termination of Interconnection Agreement. This Agreement shall terminate if the Interconnection Agreement terminates and such termination is not a result of a default by either Party or if Seller provides notice prior to interconnection of the facilities that it will not interconnect the facilities; provided, however, that nothing herein shall relieve Seller of any costs incurred by IPL prior to receipt of such notice. In the event of such a termination, neither Party shall be entitled to recover Losses from each other.

10.4 Seller Defaults and Buyer Remedies.

(a) Seller Defaults. The following events shall be defaults with respect to Seller (each, a "Seller Default"):

- (i) A Bankruptcy Event shall have occurred with respect to Seller;
- (ii) Seller's default of the Interconnection Agreement resulting in termination of the Interconnection Agreement;
- (iii) Seller fails to pay Buyer any undisputed amount owed under the Agreement within thirty (30) days after receipt of notice from Buyer of such past due amount;
- (iv) If the representations and warranties and other statements made by Seller hereunder misrepresent a material fact as of the Effective Date, and such misrepresentation has a material adverse effect and such effect is not cured within thirty (30) days from the earlier of (a) notice from the Buyer and (b) the discovery or determination by Seller of the misrepresentation; provided, that if Seller commences an action to cure such misrepresentation within such thirty (30) day period, and thereafter proceeds with all due diligence to cure such failure, the cure period shall extend for an additional thirty (30) days; and
- (v) Any of the following shall constitute an Event of Default upon occurrence but shall be subject to cure within ninety (90) days after the date of written notice from Buyer to Seller, provided that if such failure is not capable of being cured within the ninety (90)

day period, then the cure period will be extended for an additional reasonable period of time, not to exceed one hundred twenty (120) days so long as Seller is exercising reasonable diligence to cure such failure:

- (1) The Environmental Attributes generated by the Facility cannot be certified as renewable for Buyer's use;
- (2) Seller's failure to comply with any material obligation under this Agreement which would result in a material adverse impact on Buyer;
- (3) The Sale by Seller to a third party, or diversion by Seller for any use, of energy committed or Environmental Attributes to Buyer by Seller;
- (4) Seller fails to generate energy from the Facility in parallel with Buyer's electric system within twelve (12) months after completion of the interconnection provided for by this Agreement;
- (5) The Facility is removed from the Seller's premise; or
- (6) There is no production for a 12-month period.

(b) Financing Party's Right to Cure Default of Seller. Seller shall provide Buyer with a notice identifying any Financing Party and providing appropriate contact information for the Financing Party. Following receipt of such notice, Buyer shall provide notice of any Seller Default to the Financing Party concurrently with the provision of such notice to Seller. The Financing Parties shall have the right, but not the obligation, to pay all sums due under the Agreement and to perform any other act, duty or obligation required of Seller thereunder or cause to be cured any default of Seller thereunder in the time and manner provided by the terms of the Agreement if the Financing Parties send a written notice to Buyer prior to the end of any cure period indicating the Financing Parties' intention to cure. Nothing herein requires a Financing Party to cure any default of Seller under the Agreement or (unless and until such Financing Party has succeeded to Seller's interests under this Agreement) to perform any act, duty or obligation of Seller under the Agreement, but Buyer hereby gives the Financing Parties the option to do so.

(c) Buyer's Remedies. If a Seller Default described in Section 10.4(a) has occurred and is continuing, in addition to all rights and remedies expressly provided herein, and subject to Section 10.9, Buyer may terminate the Agreement; provided that no such termination or exercise of remedies may occur unless and until written notice of Seller Default has been delivered by Buyer to each Financing Party, and such Seller Default has not been cured within thirty (30) days of delivery of such notice or a Financing Party has failed to commence and pursue a cure within such thirty (30) day period if a longer cure period is needed. Upon a Seller

default, the Seller shall pay to the Buyer as liquidated damages the net present value (calculated using a discount rate of seven percent) of the difference, if positive, between (i) the amount that Buyer pays to a third party if it chooses to secure a replacement power purchase agreement for renewable energy using Commercially Reasonable Efforts for the energy that would have been delivered by Seller hereunder during the remainder of the Term (absent termination of this Agreement and based on an assumption as to the amount of energy calculated using Commercially Reasonable projections based on historical performance of the Facility), and (ii) the amount that Buyer would have been required to pay to Seller pursuant to this Agreement for such energy provided that in the event Buyer is unable to purchase replacement electric energy that includes Environmental Attributes, then the net amount described in clause (i) shall also include the then-current amount of the Environmental Attributes (on a per MWh basis) for each MWh of such energy that Buyer was unable to purchase. Such damages constitute liquidated damages, and not penalties, in lieu of Buyer's actual damages resulting from the early termination of the Agreement. Seller further acknowledges that Buyer's actual damages may be impractical and difficult to accurately ascertain, and in accordance with Seller's rights and obligations under the Agreement, the specified damages constitutes fair and reasonable damages to be borne by Seller in lieu of Buyer's actual damages.

10.5 Buyer Defaults and Seller's Remedies.

- (a) Buyer Default. The following events shall be defaults with respect to Buyer (each, a "Buyer Default"):
- (i) A Bankruptcy Event shall have occurred with respect to Buyer;
 - (ii) Buyer's default of the Interconnection Agreement resulting in termination of the Interconnection Agreement;
 - (iii) Buyer fails to pay Seller any undisputed amount owed under the Agreement within thirty (30) days after receipt of notice from Seller of such past due amount which failure is not remedied by Buyer within ten (10) days after the date of written notice from Seller to Buyer of such failure;
 - (iv) Buyer breaches any material term of the Agreement if (A) such breach can be cured within thirty (30) days after Seller's notice of such breach and Buyer fails to so cure, or (B) Buyer fails to commence and pursue said cure within such thirty (30) day period if a longer cure period is needed
 - (v) If the representations and warranties and other statements made by Buyer hereunder misrepresent a material fact as of the Effective Date, and such misrepresentation has a material adverse effect and such effect is not cured within thirty (30) days from the earlier of (a) notice from the Seller and (b) the discovery or determination by Buyer of the misrepresentation; provided, that if Buyer commences an action to cure such misrepresentation within such thirty (30) day

period, and thereafter proceeds with all due diligence to cure such failure, the cure period shall extend for an additional thirty (30) days; and

- (vi) Buyer supports before a Governmental Authority, directly or indirectly, any cancellation of this Agreement or a change in any law or rule or any other mechanism solely designed to disallow the recovery of any costs associated with the Buyer's purchase of electricity, capacity or Environmental Attributes under this Agreement through its retail rates.

(b) Seller's Remedies. If a Buyer Default described in Section 10.5(a) has occurred and is continuing, and subject to Section 10.9, Seller may terminate the Agreement and upon such termination, Seller shall be entitled to receive from Buyer the net present value (calculated using a discount rate of seven percent) of the difference, if positive, between: (i) the rate for purchase in Section 7.1 multiplied by the amount of energy that would have been delivered by Seller hereunder during the remainder of the Term (absent termination of this Agreement and based on an assumption as to the amount of energy calculated using Commercially Reasonable projections based on historical performance of the Facility), less (ii) the net amount, if any, payable to Seller by a third party pursuant to any replacement power purchase agreement that Seller using Commercially Reasonable Efforts enters into for the sale of the energy and less (iii) the net salvage value of any portion of the Facility that Seller transfers or reasonably could transfer if Seller cannot sell its energy to a third party and (iv) if Seller does not enter into a replacement power purchase agreement for the sale of energy from the Facility, less the net present value (calculated using a discount rate of seven percent) of avoided operation and maintenance expenses, agreed to be \$0.01 per kWh, multiplied by the amount of energy that would have been delivered by Seller hereunder during the remainder of the Term (absent termination of this Agreement and based on an assumption as to the amount of energy calculated using Commercially Reasonable projections based on historical performance of the Facility). Such damages constitute liquidated damages, and not penalties, in lieu of Seller's actual damages resulting from the early termination of the Agreement. Buyer further acknowledges that Seller's actual damages may be impractical and difficult to accurately ascertain, and in accordance with Buyer's rights and obligations under the Agreement, the specified damages constitutes fair and reasonable damages to be borne by Buyer in lieu of Seller's actual damages.

10.6 Duty to Mitigate. Each Party agrees that it has a duty to mitigate damages and covenants that it will use Commercially Reasonable Efforts to minimize any damages it may incur as a result of the other Party's performance or non-performance of the Agreement.

10.7 Cooperation in Calculation of Damages. Each Party shall cooperate with the other Party in providing such access, information and data as the other Party may reasonably request as necessary and appropriate in the calculation of damages as provided for under this Agreement.

10.8 Injunctive Relief. Either Party shall be entitled to pursue any equitable remedy available to it as a result of a breach of any material obligation of the other Party under this Agreement.

10.9 Waiver and Exclusion of Other Damages. The Parties confirm that the express remedies and measures of damages provided in this Agreement satisfy the essential purposes hereof. If no remedy or measure of damages is expressly herein provided, the obligor's liability shall be limited to direct, actual damages only. NEITHER PARTY SHALL BE LIABLE TO THE OTHER PARTY FOR CONSEQUENTIAL, INCIDENTAL, PUNITIVE, EXEMPLARY OR INDIRECT DAMAGES, LOST PROFITS, RECAPTURE OF INVESTMENT TAX CREDITS, RECAPTURE OF TREASURY GRANTS IN LIEU OF INVESTMENT TAX CREDITS, RECAPTURE OF NEW MARKETS TAX CREDITS, RECAPTURE OF OTHER FEDERAL OR STATE TAX OR FINANCIAL INCENTIVES OR OTHER BUSINESS INTERRUPTION DAMAGES BY STATUTE, IN TORT OR CONTRACT (EXCEPT TO THE EXTENT EXPRESSLY PROVIDED HEREIN); PROVIDED, THAT IF EITHER PARTY IS HELD LIABLE TO A THIRD PARTY FOR SUCH DAMAGES AND THE PARTY HELD LIABLE FOR SUCH DAMAGES IS ENTITLED TO INDEMNIFICATION THEREFORE FROM THE OTHER PARTY HERETO, THE INDEMNIFYING PARTY SHALL BE LIABLE FOR, AND OBLIGATED TO REIMBURSE THE INDEMNIFIED PARTY FOR, SUCH DAMAGES. Any amounts which are expressly provided herein to be payable shall be treated as direct damages and shall not fall within the exclusion in the preceding sentence. To the extent any damages required to be paid hereunder are liquidated, the Parties acknowledge that the damages are difficult or impossible to determine, that otherwise obtaining an adequate remedy is inconvenient, and that the liquidated damages constitute a reasonable approximation of the harm or loss.

11. ASSIGNMENT.

11.1 Assignment by Seller. Seller shall not sell, transfer or assign (collectively, an "Assignment") the Facility or Seller's rights or obligations under the Agreement or any interest therein, without the prior written consent of Buyer, which shall not be unreasonably withheld, conditioned or delayed; provided, however, that, without the prior consent of Buyer, Seller may (i) assign the Agreement to an Affiliate of Seller so long as Seller remains fully liable for all obligations under this Agreement in the event of any nonperformance on the part of such assignee and *further provided,* that Seller provides assurances and executes documents required by Buyer regarding Seller's continued liability for all of Seller's obligations under this Agreement in the event of any nonperformance on the part of such assignee; and (ii) assign the Agreement to one or more Financing Parties as collateral security in connection with any financing of the Facility (including, without limitation, pursuant to a sale-leaseback or partnership flip transaction). Any assignment by Seller without any required prior written consent of Buyer shall not release Seller of its obligations hereunder. Seller shall notify Buyer, of any such assignment no later than thirty (30) days after the assignment.

11.2 Acknowledgment of Collateral Assignment. Buyer acknowledges that Seller will be financing the installation of the Facility through one or more Financing Parties and that Seller may sell or assign the Facility or may secure Seller's obligations by, among other collateral, a pledge or collateral assignment of the Agreement and a first security interest in the Facility. To facilitate Seller's obtaining of financing for installation of the Facility, in the event that Seller identifies a Financing Party in a subsequent notice to Buyer, then Buyer hereby:

- (a) Agrees to negotiate in good faith to enter into a Consent and Agreement with such Financing Party in substantially the form attached hereto as Exhibit B.
- (b) Agrees to make commercially reasonable efforts to provide such other consents to assignments, certifications, representations, information or other documents as may be requested by Seller or the Financing Party in connection with the financing of the Facility; provided, that in responding to any such request, Buyer shall have no obligation to provide any consent, or enter into any agreement, that materially adversely affects any of Buyer's rights, benefits, risks or obligations under this Agreement.

Seller shall reimburse, or shall cause the Financing Party to reimburse, Buyer for the expenses (including the reasonable fees and expenses of counsel) incurred by Buyer directly in the preparation, negotiation, execution or delivery of any documents requested by Seller or the Financing Party, and provided by Buyer, pursuant to this Section 11.2.

In no event shall any debt secured by Seller in connection with the Facility provide recourse against Buyer or in any way imply that Buyer is responsible for or acts as a primary obligor, surety, or guarantor of such debt.

11.3 Assignment by Buyer. Buyer shall not assign the Agreement or any interest therein, without Seller's prior written consent, which consent shall not be unreasonably withheld, conditioned or delayed; provided, however, that, without the prior consent of Seller, Buyer may assign the Agreement to an Affiliate of Buyer so long as Buyer remains fully liable for all obligations under this Agreement in the event of any nonperformance on the part of such assignee and further provided, that Buyer provides assurances and executes documents required by Seller regarding Buyer's continued liability for all of Buyer's obligations under this Agreement in the event of any nonperformance on the part of such assignee. Any assignment by Buyer without the prior written consent of Seller shall not release Buyer of its obligations hereunder.

12. CONFIDENTIALITY

12.1 Confidentiality Obligation. If any Party provides confidential information, including business plans, strategies, financial information, proprietary, patented, licensed, copyrighted or trademarked information, and/or technical information regarding the financing, design, operation and maintenance of the Facility or of Company's business ("Confidential Information") to the others or, if in the course of performing under the Agreement or negotiating the Agreement a Party learns Confidential Information regarding the facilities or plans of the others, the receiving Party shall (a) protect the Confidential Information from disclosure to third parties with the same degree of care accorded its own confidential and proprietary information, and (b) refrain from using such Confidential Information, except in the negotiation and performance of the Agreement. A Party may provide such Confidential Information to individuals on a need to know basis (provided and on condition that such potential assignees be bound by a written agreement restricting use and disclosure of Confidential Information) (collectively, "Permitted Recipients"). Each such recipient of Confidential Information shall be

informed by the Party disclosing Confidential Information of its confidential nature and shall be directed to treat such information confidentially and shall agree to abide by these provisions. In any event, each Party shall be liable (with respect to the other Party) for any breach of this provision by any entity to whom that Party improperly discloses Confidential Information. The terms of the Agreement (but not its execution or existence) shall be considered Confidential Information for purposes of this Section 12.1, except as set forth in Section 12.2. All Confidential Information shall remain the property of the disclosing Party and shall be returned to the disclosing Party or destroyed after the receiving Party's need for it has expired or upon the request of the disclosing Party.

12.2 Permitted Disclosures. Notwithstanding any other provision herein, neither Party shall be required to hold confidential any information that:

- (a) becomes publicly available other than through the receiving Party;
- (b) is required to be disclosed by a Governmental Authority, under Applicable Law or pursuant to a validly issued subpoena or required filing, or is disclosed to a Governmental Authority pursuant to an order protecting such information from public disclosure and after a receiving Party promptly notifies the disclosing Party of such disclosure;
- (c) is disclosed to a party in a proceeding before a Governmental Authority not a competitor of another Party pursuant to a non-disclosure agreement prohibiting dissemination beyond such party and limiting its use to such proceeding;
- (d) is independently developed by the receiving Party; or
- (e) becomes available to the receiving Party without restriction from a third party under no obligation of confidentiality.

12.3 Goodwill and Publicity. No Party shall use the name, trade name, service mark, or trademark of another Party in any promotional or advertising material without the prior written consent of such other Party. The Parties shall coordinate and cooperate with each other when making public announcements related to the execution and existence of the Agreement, and each Party shall have the right to promptly review, comment upon, and approve any publicity materials, press releases, or other public statements by the other Parties that refer to, or that describe any aspect of, the Agreement; provided that no such publicity releases or other public statements (except for filings or other statements or releases as may be required by Applicable Law) shall be made by any Party without the prior written consent of the other Party. At no time will any Party acquire any rights whatsoever to any trademark, trade name, service mark, logo or other intellectual property right belonging to the other Parties.

12.4 Enforcement of Confidentiality Obligation. Each Party agrees that the disclosing Party would be irreparably injured by a breach of this Section 12 by the receiving Party or its Permitted Recipients or other Person to whom the receiving Party discloses Confidential Information of the disclosing Party and that the disclosing Party may be entitled to equitable relief, including injunctive relief and specific performance, in the event of any breach of the

provisions of this Section 12. To the fullest extent permitted by Applicable Law, such remedies shall not be deemed to be the exclusive remedies for a breach of this Section 12, but shall be in addition to all other rights remedies available at law or in equity.

13. FORCE MAJEURE.

If either Party is rendered wholly or partly unable to perform its obligations under this Agreement because of Force Majeure, both Parties shall be excused from whatever obligations under this Agreement are affected by the Force Majeure (other than the obligation to pay money) and shall not be liable or responsible for any delay in the performance of, or the inability to perform, any such obligations for so long as the Force Majeure continues. The Party suffering an occurrence of Force Majeure shall, as soon as is reasonably possible after such occurrence, give the other Party written notice describing the particulars of the occurrence and shall use commercially reasonable efforts to remedy its inability to perform; provided, however, that the settlement of any strike, walkout, lockout or other labor dispute shall be entirely within the discretion of the Party involved in such labor dispute.

14. DISPUTES.

In the event of a dispute between the Parties arising out of or relating to this Agreement, such dispute shall be submitted within twenty (20) days of written notice, to a management panel composed of representatives of the respective Parties for informal dispute resolution or settlement prior to the institution of any other dispute resolution process. Should the informal dispute resolution process described herein be unsuccessful, the Parties agree that no written or oral representations made during the course of the attempted dispute resolution shall constitute a Party admission or waiver and that each Party may pursue any other legal or equitable remedy it may have available to it. The Parties agree that the existence of any dispute or the institution of any dispute resolution process (either formal or informal) shall not delay the performance of each Party's undisputed responsibilities under this Agreement.

15. MISCELLANEOUS

15.1 Termination of Any Applicable Existing Agreement. From and after the date when service commences under this Agreement, this Agreement shall supersede any oral and/or written agreement or understanding between Buyer and Seller concerning the service covered by this Agreement and any such agreement or understanding shall be deemed to be terminated as of the date service commences under this Agreement.

15.2 Forward Contract. The Parties acknowledge and agree that this Agreement and the transactions contemplated by this Agreement constitute a "forward contract" within the meaning of the United States Bankruptcy Code and that Seller is a "forward contract merchant" within the meaning of the United States Bankruptcy Code.

15.3 Notices. Except as otherwise provided in this Agreement, any notice, request, consent, demand, or statement which is contemplated to be made upon either Party hereto by the other Party hereto under any of the provisions of this Agreement, shall be in writing and sent by certified mail with a return receipt requested or via overnight courier with tracking capability to the address set forth below:

If notice or other transmittal (other than payment of invoices) is to Buyer:

Indianapolis Power & Light Company
One Monument Circle
Indianapolis, IN 46204
Attention: Director, Regulatory Affairs

With a copy to:

Indianapolis Power & Light Company
One Monument Circle
Indianapolis, IN 46204
Attention: Office of the General Counsel

If notice or other transmittal is to Seller:

5855, LP
338 South Arlington Avenue, Suite 202
Indianapolis, IN 46219

Attention: Margaret Banning

With a copy to:

Irvington Partners
13099 Parkside Dr.
Fishers, IN 46038
Attention: Tom Peck

15.4 Governing Law. THIS AGREEMENT AND THE RIGHTS AND DUTIES OF THE PARTIES HEREUNDER SHALL BE GOVERNED BY AND CONSTRUED, ENFORCED AND PERFORMED IN ACCORDANCE WITH THE LAWS OF THE STATE OF INDIANA, WITHOUT REGARD TO PRINCIPLES OF CONFLICTS OF LAW. EACH PARTY WAIVES ITS RESPECTIVE RIGHT TO ANY JURY TRIAL WITH RESPECT TO ANY LITIGATION ARISING UNDER OR IN CONNECTION WITH THIS AGREEMENT.

15.5 Compliance with Laws. Each Party shall at all times comply with all applicable laws, except for any non-compliance which, individually or in the aggregate, could not reasonably be expected to have a material adverse effect on the business or financial condition of the Party or its ability to fulfill its commitments hereunder. As applicable, each Party shall give all required notices, shall procure and maintain all necessary governmental permits, licenses, and inspections necessary for performance of this Agreement, and shall pay its respective charges and fees in connection therewith.

15.6 Limited Effect of Waiver. The failure of Seller or Buyer to enforce any of the provisions of the Agreement, or the waiver thereof, shall not be construed as a general waiver or relinquishment on its part of any such provision, in any other instance or of any other provision in any instance.

15.7 Severability. If any term, covenant or condition in the Agreement shall, to any extent, be invalid or unenforceable in any respect under Applicable Law, the remainder of the Agreement shall not be affected thereby, and each term, covenant or condition of the Agreement shall be valid and enforceable to the fullest extent permitted by Applicable Law and, if appropriate, such invalid or unenforceable provision shall be modified or replaced to give effect to the underlying intent of the Parties and to the intended economic benefits of the Parties.

15.8 Relation of the Parties. The relationship between Seller and Buyer shall not be that of partners, agents, or joint ventures for one another, and nothing contained in the Agreement shall be deemed to constitute a partnership or agency agreement between them for any purposes, including federal income tax purposes. Seller and Buyer, in performing any of their obligations hereunder, shall be independent contractors or independent parties and shall discharge their contractual obligations at their own risk.

15.9 Integration; Exhibits. The Agreement, together with the Exhibits attached thereto and hereto, constitute the entire agreement and understanding between Parties with respect to the subject matter thereof and supersedes all prior agreements relating to the subject matter hereof, which are of no further force or effect. The Exhibits attached thereto and hereto are integral parts hereof and are made a part of the Agreement by reference.

15.10 Amendments. The Agreement may only be amended, modified or supplemented by an instrument in writing executed by duly authorized representatives of Seller and Buyer.

15.11 Audit. Each Party has the right, at its sole expense and during normal working hours, to examine the records of the other Party to the extent reasonably necessary to verify the accuracy of any statement, charge or computation made pursuant to this Agreement. If requested, a Party shall provide to the other Party statements evidencing the quantity of energy delivered at the Delivery Point. If any such examination reveals any inaccuracy in any statement, the necessary adjustments in such statement and the payments thereof will be made promptly.

15.12 Fines and Penalties. Each Party shall pay when due all fees, fines, penalties or costs incurred by that Party or its agents, employees or contractors for noncompliance by that Party, its employees, or subcontractors with any provision of this Agreement, or any contractual obligation, permit or requirements of law except for such fines, penalties and costs that are being actively contested in good faith and with due diligence by that Party and for which adequate financial reserves have been set aside to pay such fines, penalties or costs in the event of an adverse determination.

15.13 Disclaimer of Third Party Beneficiary Rights. In executing this Agreement, Buyer does not, nor should it be construed to, extend its credit or financial support for the benefit of any third parties lending money to or having other transactions with Seller. Nothing in this

Agreement shall be construed to create any duty to, or standard of care with reference to, or any liability to, any person not a party to this Agreement.

15.14 Employees. Each Party shall be solely liable for the payment of all wages, taxes, and other costs related to the employment of persons to perform its obligations under this Agreement, including all federal, state, and local income, social security, payroll, and employment taxes and statutorily mandated workers' compensation coverage. None of the persons employed by either Party shall be considered employees of the other Party for any purpose; nor shall either Party represent to any person that he or she is or shall become an employee of the other Party.

IN WITNESS WHEREOF, the Parties have executed this Agreement, effective as of the Effective Date first above written.

Indianapolis Power & Light Company
("Buyer")

By: William H. Henley

Printed: William H. Henley

Title: VP Corporate Affairs

Execution Date: 2/19/13

5855, LP
("Seller")

By: Margaret Lawrence Banning

Printed: Margaret Lawrence Banning

Title: Executive Director of the Sole Member
of the General Partner

Execution Date: 8 Feb 2013

Received On: February 20, 2013
IURC 30-DAY Filing No.: 3125
Indiana Utility Regulatory Commission

EXHIBIT A

INTERCONNECTION AGREEMENT AMONG THE PARTIES



**INTERCONNECTION AGREEMENT
FOR LEVEL 2 - 2MW OR LESS OR LEVEL 3 - ALL OTHER FACILITIES**

THIS INTERCONNECTION AGREEMENT ("Agreement") is made and entered into this 18th day of February 2013, by and between **Indianapolis Power & Light Company** ("Buyer") and **5855, LP** ("Seller"). Buyer and Seller are hereinafter sometimes referred to individually as "Party" or collectively as "Parties".

WITNESSETH:

WHEREAS, Seller is installing, or has installed, generation equipment, controls, and protective relays and equipment ("Generation Facilities") on Customer's property used to interconnect and operate in parallel with Buyer's electric system, which Generation Facilities are more fully described in Exhibit A, attached hereto and incorporated herein by this Agreement, and as follows:

Location: **5855 E. Washington Street, Indianapolis, IN 46219**

Generator Size and Type: **77.7 kW - Solar**

NOW, THEREFORE, in consideration thereof, Seller and Buyer agree as follows:

1. Application. It is understood and agreed that this Agreement applies only to the operation of the Generation Facilities described above and on Exhibit A.

2. Interconnection. Buyer agrees to allow Seller to interconnect and operate the Generation Facilities in parallel with Buyer's electric system in accordance with any operating procedures or other conditions specified in Exhibit A. By this Agreement, or by inspection, if any, or by non-rejection, or by approval, or in any other way, Buyer does not give any warranty, express or implied, as to the adequacy, safety, compliance with applicable codes or requirements, or as to any other characteristics, of the Generation Facilities. The Generation Facilities installed shall comply with, and Seller represents and warrants their compliance with: (a) the National Electrical Code and the National Electrical Safety Code, as each may be revised from time to time; (b) Buyer's rules and regulations, including Buyer's General Terms and Conditions for Electric Service as contained in Buyer's Retail Electric Tariff and as each may be revised from time to time with the approval of the Indiana Utility Regulatory Commission ("Commission"); and (c) all other applicable local, state, and federal codes and laws, as the same may be in effect from time to time.

Seller shall install, operate, and maintain, at Seller's sole cost and expense, the Generation Facilities in accordance with the manufacturer's suggested practices for safe, efficient and reliable operation of the Generation Facilities in parallel with Buyer's electric system. Customer and Seller shall bear full responsibility for the installation, maintenance and safe operation of the Generation Facilities. Customer and Seller shall be responsible for protecting, at Seller's sole cost and expense, the Generation Facilities from any condition or disturbance on Buyer's electric system, including, but not limited to, voltage sags or swells, system faults, outages, loss of a single phase of supply, equipment failures, and lightning or switching surges.

Seller agree that, without the prior written permission from Buyer, no changes shall be made to the configuration of the Generation Facilities, as that configuration is described in Exhibit A, and no relay or other control or protection settings specified in Exhibit A shall be set, reset, adjusted or tampered with, except to the extent necessary to verify that the Generation Facilities comply with Buyer approved settings.

3. Operation by Seller. Seller shall not operate the Generation Facilities in such a manner as to cause undue fluctuations in voltage, intermittent load characteristics or otherwise interfere with the operation of Buyer's electric system. At all times when the Generation Facilities are being operated in parallel with Buyer's electric system, Seller shall so operate the Generation Facilities in such a manner that no disturbance will be produced thereby to the service rendered by Buyer to any of Buyer's other customers or to any electric system interconnected with Buyer's electric system. Seller understands and agrees that the interconnection and operation of the Generation Facilities pursuant to this Agreement is secondary to, and shall not interfere with, Buyer's ability to meet its primary responsibility of furnishing reasonably adequate service to its customers.

The control equipment for the Generation Facilities shall immediately, completely, and automatically disconnect and isolate the Generation Facilities from Buyer's electric system in the event of a fault on Buyer's electric system, a fault on the Generating Facilities' electric system, or loss of a source or sources on Buyer's electric system. The automatic disconnecting device included in such control equipment shall not be capable of reclosing until after service is restored on Buyer's electric system. Seller represents and warrants to Buyer that the control equipment complies with the foregoing requirements. Additionally, if the fault is on the Generating Facilities' electric system, such automatic disconnecting device shall not be reclosed until after the fault is isolated from the Generating Facilities' electric system. Upon Buyer's request, Seller shall promptly notify Buyer whenever such automatic disconnecting devices operate.

4. Access by Buyer. Upon reasonable advance notice to Seller, Buyer shall have access at reasonable times to the Generation Facilities whether before, during or after the time the Generation Facilities first produce energy, to perform reasonable on-site inspections to verify that the installation and operation of the Generation Facilities comply with the requirements of this Agreement and to verify the proper installation and continuing safe operation of the Generation Facilities. Buyer shall also have, at all times, immediate access to breakers or any other equipment that will isolate the Generation Facilities from Buyer's electric system. The cost of such inspection(s) shall be at Buyer's expense; however, Buyer shall not be responsible for any other cost Seller may incur as a result of such inspection(s). Buyer shall have the right and authority to temporarily disconnect the Generation Facilities at Buyer's sole discretion if Buyer believes that: (a) for scheduled outages upon reasonable notice; (b) for unscheduled outages or emergency conditions; (c) if Buyer determines that continued operation of the Generation Facilities is a safety hazard to Buyer's personnel or to the general public; (d) continued interconnection and parallel operation of the Generation Facilities with Buyer's electric system creates or contributes (or will create or contribute) to a system emergency on either Buyer's or Customer's electric system; (e) the Generation Facilities are not in compliance with the requirements of this Agreement, and the non-compliance adversely affects the safety, reliability or power quality of Buyer's electric system; (f) in the event the interconnection equipment used by the Generation Facilities is de-listed by the nationally recognized testing laboratory that provided the listing at the time the interconnection was approved and the Buyer determines that the continued operation has the potential to cause a safety, reliability or power quality problem or (g) the Generation Facilities interfere with the operation of Buyer's electric system. In non-emergency situations, Buyer shall give Seller reasonable notice prior to isolating the Generating Facilities.

5. Rates and Other Charges. This Agreement does not constitute an agreement by Buyer to purchase or wheel power produced by the Generation Facilities, or to furnish any backup, supplemental or other power or services associated with the Generation Facilities, and this Agreement does not address any charges for excess facilities that may be installed by Buyer in connection with interconnection of the Generation Facilities. It is understood that if Seller desires an agreement whereby Buyer wheels power, or purchases energy and/or capacity, produced by the Generation Facilities, or furnishes any backup, supplemental or other power or services

associated with the Generation Facilities, then Buyer may enter into another mutually acceptable separate agreement with Customer or Seller detailing the charges, terms and conditions of such purchase or wheeling, or such backup, supplemental or other power or services. It is also understood that if any such excess facilities are required, including any additional metering equipment as determined by Buyer, in order for the Generation Facilities to interconnect with and operate in parallel with Buyer's electric system, then Seller shall enter into an Excess Facilities Agreement with Buyer in accordance with Buyer's Standard Contract Rider No. 4 contained in Buyer's Retail Electric Tariff, which rider details the charges and terms of such excess facilities, as the same may be revised from time to time with the approval of the Commission.

6. Insurance. The Seller shall procure and keep in force during all periods of parallel operation of the Generation Facilities with Buyer's electric system, the following insurance to protect the interests of Buyer under this Agreement, with insurance carriers acceptable to Buyer, and in amounts not less than the following:

Coverage	Limits
Comprehensive General Liability	\$5,000,000.00
Contractual Liability	\$5,000,000.00
Bodily Injury	\$5,000,000.00
Property Damage	\$5,000,000.00

Seller shall deliver a CERTIFICATE OF INSURANCE verifying the required coverage to:

Attention: Mr. Bruce Smith
Address One Monument Circle Indianapolis IN, 46204

at least fifteen (15) days prior to any interconnection of the Generation Facilities with Buyer's electric system, and thereafter as requested by Buyer.

If the Seller is sufficiently creditworthy, as determined by Buyer, then, in lieu of obtaining all or part of the above-specified required insurance coverage from insurance carriers acceptable to Buyer, Seller may self insure all or part of such required insurance coverage provided that Seller agrees to defend Buyer and to provide on a self insurance basis insurance benefits to Buyer, all to the same extent as would have been provided under this Agreement pursuant to the above insurance provisions of this Section 6. By utilizing self insurance to provide all or part of the above-specified required insurance, Seller shall be deemed to have agreed to the provisions of the previous sentence of this Section 6.

7. Commission Rules. Each Party agrees that the interconnection of the Generating Facilities is exempt from the requirements of 170 IAC 4-4.3-1, *et seq.* to the fullest extent permitted by 170 IAC 4-4.3-3(b).

8. Indemnification. Each Party (the "Indemnifying Party") shall indemnify and hold harmless the other Party from and against all claims, liability, damages and expenses, including attorney's fees, based on any injury to any person, including the loss of life, or damage to any property, including the loss of use thereof, arising out of, resulting from, or connected with, or that may be alleged to have arisen out of, resulted from, or connected with, an act or omission by the Indemnifying Party, its employees, agents, representatives, successors or assigns in the construction, ownership, operation or maintenance of the Indemnifying Party's facilities used in connection with this Agreement. In addition, no Party is the agent or representative of any other Party under this Agreement. Upon written request of the Party seeking relief under this Section 8, the Indemnifying Party shall defend any suit asserting a claim covered by this Section 8. If a

Party is required to bring an action to enforce its rights under this Section 8, either as a separate action or in connection with another action, and said rights are upheld, the Indemnifying Party shall reimburse such Party for all reasonable expenses, including attorney's fees, incurred in connection with such action.

9. **Term.** This Agreement shall become effective when executed by all Parties and shall continue in effect for a period of thirty (30) years (the "Initial Term"). After the Initial Term, this Agreement shall renew for one (1) year periods unless a Party serves notice on all other Parties giving notice of its intent not to renew at least sixty (60) days prior to the expiration of the then current term.

10. **Termination.**

a. Seller Defaults. The following events shall be defaults with respect to Seller (each a "Seller Default"):

- i Seller fails to generate energy from the Generation Facilities in parallel with Buyer's electric system within twelve (12) months after completion of the interconnection provided for by this Agreement;
- ii Seller fails to pay when due any amounts owing to Buyer or Host Facility under the Agreement or fails to indemnify another party;
- iii Seller fails, within sixty (60) days of written notice provided by Buyer, to take corrective action to bring the Generation Facilities' interconnection in compliance with the terms of the Agreement; or

b. Seller breaches any material term of the Agreement if (A) such breach can be cured within thirty (30) days after Buyer's notice of such breach and Seller fails to so cure or (B) Seller fails to commence and pursue said cure within such thirty (30) day period if a longer cure period is needed.

c. Buyer Defaults. Buyer shall commit a default (an "Buyer Default") if it breaches any material term of the Agreement if such breach can be cured within thirty (30) days after Seller's or Host Facility's notice of such breach and Company fails to so cure or (B) ~~Seller~~ fails to commence and pursue said cure within such thirty (30) day period if a longer cure period is needed.

Buyer
mclB

d. Termination. The Agreement may terminate prior to the expiration of the Initial Term or any subsequent term at the earliest date that one of the following events occur:

- i. In the event of a Seller Default or a Buyer Default and the default is continuing, the non-defaulting party may terminate the Agreement;
- ii. The Parties mutually agree in writing to terminate the Agreement; or
- iii. In the event operation of the Generation Facilities becomes illegal or impracticable as the consequence of the application of any statute, law or governmental rule or regulation or compliance with such regulation requires Buyer to incur costs and the Seller or Host Facility are unwilling to reimburse Buyer for such cost.

e. Permanent Disconnection. In the event the Agreement is terminated, Buyer shall have the right to disconnects the Generation Facilities or direct the Seller to disconnect the Generation Facilities.

11. Termination of Any Applicable Existing Agreement. From and after the date when service commences under this Agreement, this Agreement shall supersede any prior oral and/or written agreement or understanding between Buyer and Seller concerning the service covered by this Agreement and any such agreement or understanding shall be deemed to be terminated as of the date service commences under this Agreement.

12. Force Majeure. For purposes of this Agreement, the term "Force Majeure" means any cause or event not reasonably within the control of the Party claiming Force Majeure, including, but not limited to, the following: acts of God, strikes, lockouts, or other industrial disturbances; acts of public enemies; orders or permits or the absence of the necessary orders or permits of any kind which have been properly applied for from the government of the United States, the State of Indiana, any political subdivision or municipal subdivision or any of their departments, agencies or officials, or any civil or military authority; unavailability of a fuel or resource used in connection with the generation of electricity; extraordinary delay in transportation; unforeseen soil conditions; equipment, material, supplies, labor or machinery shortages; epidemics; landslides; lightning; earthquakes; fires; hurricanes; tornadoes; storms; floods; washouts; drought; arrest; war; civil disturbances; explosions; breakage or accident to machinery, transmission lines, pipes or canals; partial or entire failure of utilities; breach of contract by any supplier, contractor, subcontractor, laborer or material man; sabotage; injunction; blight; famine; blockade; or quarantine.

If any Party is rendered wholly or partly unable to perform its obligations under this Agreement because of Force Majeure, all Parties shall be excused from whatever obligations under this Agreement are affected by the Force Majeure (other than the obligation to pay money) and shall not be liable or responsible for any delay in the performance of, or the inability to perform, any such obligations for so long as the Force Majeure continues. The Party suffering an occurrence of Force Majeure shall, as soon as is reasonably possible after such occurrence, give the other Parties written notice describing the particulars of the occurrence and shall use commercially reasonable efforts to remedy its inability to perform; provided, however, that the settlement of any strike, walkout, lockout or other labor dispute shall be entirely within the discretion of the Party involved in such labor dispute.

13. Limitation of Liability. BUYER'S TOTAL LIABILITY TO THE SELLER FOR ALL CLAIMS OR SUITS OF ANY KIND, WHETHER BASED UPON CONTRACT, TORT (INCLUDING NEGLIGENCE), WARRANTY, STRICT LIABILITY OR OTHERWISE, FOR ANY LOSSES, DAMAGES, COSTS OR EXPENSES OF ANY KIND WHATSOEVER ARISING OUT OF, RESULTING FROM, OR RELATED TO THE PERFORMANCE OR BREACH OF THIS CONTRACT SHALL, UNDER NO CIRCUMSTANCES, EXCEED THE FINAL COST OF ANY INTERCONNECTION FACILITIES PAID FOR BY THE CUSTOMER-GENERATOR. BUYER SHALL NOT, UNDER ANY CIRCUMSTANCES, BE LIABLE FOR ANY SPECIAL, INDIRECT, INCIDENTAL, PUNITIVE, OR CONSEQUENTIAL LOSSES, DAMAGES, COSTS, OR EXPENSES WHATSOEVER (INCLUDING, BUT NOT LIMITED TO, LOST OR REDUCED PROFITS, REVENUES, EFFICIENCY, PRODUCTIVITY, BONDING CAPACITY, OR BUSINESS OPPORTUNITIES, OR INCREASED OR EXTENDED OVERHEAD, OPERATING, MAINTENANCE OR DEPRECIATION COSTS AND EXPENSES).

14. Dispute Resolution. In the event of a dispute between the Parties arising out of or relating to this Agreement, such dispute shall be submitted within twenty (20) days of written notice, to a management panel composed of representatives of the respective Parties for informal dispute resolution or settlement prior to the institution of any other dispute resolution process. Should the informal dispute resolution process described herein be unsuccessful, the Parties agree that no written or oral representations made during the course of the attempted dispute resolution shall constitute a Party admission or waiver and that each Party may pursue any other legal or equitable remedy it may have available to it. The Parties agree that the existence of any

dispute or the institution of any dispute resolution process (either formal or informal) shall not delay the performance of each Party's undisputed responsibilities under this Agreement.

15. Notices. Except with respect to the notice of access required by paragraph 4, which notice shall be orally or in writing, at Buyer's election, or as otherwise provided in this Agreement, any notice, request, consent, demand, or statement which is contemplated to be made upon any Party hereto by any other Party hereto under any of the provisions of this Agreement, shall be in writing and sent by certified mail to all other Parties with a return receipt requested or via overnight courier with tracking capability to the address set forth below:

If notice or other transmittal (other than payment of invoices) is to Company:

Indianapolis Power & Light Company
One Monument Circle
Indianapolis, IN 46204
Attention: Director, Regulatory Affairs
Telephone: (317) 261-6713

With a copy to:

Indianapolis Power & Light Company
One Monument Circle
Indianapolis, IN 46204
Attention: Office of the General Counsel
Telephone: (317) 261-8337

If notice or other transmittal is to Seller:

Irvington Development Organization
P.O. Box 19714
Indianapolis, IN 46219
Attention: Margaret Banning
Telephone: 317-260-0669

With a copy to:

Irvington Partners
13099 Parkside Dr.
Fishers, IN 46038
Attention: Tom Peck

16. Assignment. No Party shall assign, sublet or otherwise transfer its rights or obligations under this Agreement, or any portion thereof, without the prior written consent of the other Parties, and any attempted assignment, subletting or transfer without such written consent shall be of no force or effect, which consent cannot be unreasonably withheld. As to any permitted assignment: (a) reasonable prior notice of any such assignment shall be given to the other Parties; and (b) any assignee shall expressly assume the assignor's obligations hereunder, unless otherwise agreed to by the other Parties in writing.

17. Commission Jurisdiction and Buyer Rules. Buyer is subject to the jurisdiction of the Commission. To the extent that Commission approval of this Agreement may be required now or in the future, this Agreement and Buyer's commitments hereunder are subject to such approval.

18. Non-Waiver. None of the provisions of this Agreement shall be considered waived by a Party unless such waiver is given in writing. The failure of a Party to insist in any one or more instances upon strict performance of any of the provisions of this Agreement or to take advantage of any of its rights hereunder shall not be construed as a waiver of any such provisions or the relinquishment of any such rights for the future, but the same shall continue and remain in full force and effect.

19. Governing Law. THIS CONSENT SHALL IN ALL RESPECTS BE GOVERNED BY, AND CONSTRUED IN ACCORDANCE WITH, THE LAWS OF THE STATE OF INDIANA, INCLUDING ALL MATTERS OF CONSTRUCTION, VALIDITY AND PERFORMANCE.

20. Amendment and Modification. This Agreement can only be amended or modified by a writing signed by both Parties.

21. Survival Rights. This Agreement shall continue in effect after termination to the extent necessary to allow or require either Party to fulfill its rights or obligation that arose under this Agreement.

22. No Third Party Beneficiaries. This Agreement is not intended to and does not create rights, remedies, or benefits of any character whatsoever in favor of any persons, corporation, associations, or entities other than the Parties, and the obligations herein assumed are solely for the use and benefit of the Parties, their successors in interest and, where permitted, their assigns.

23. Entire Agreement. This Agreement contains the entire Agreement and understanding between the Parties, their agents, and employees as to the subject matter of this Agreement. Each Party also represents that in entering into this Agreement, it has not relied on any promise, inducement, representation, warranty, agreement or other statement not set forth in this Agreement.

IN WITNESS WHEREOF, the Parties have executed this Agreement, effective as of the date first above written.

Indianapolis Power & Light Company

By: Barry J. Bentley

Date: 2/18/2013

Name: Barry J. Bentley

Title: Sr. Vice President Customer Operations

5855, LP

"Seller"

By: Margaret Lawrence Banning

Date: 7 February 2013

Name: Margaret Lawrence Banning

Title: Executive Director of the Sole Member of the General Partner

EXHIBIT A

Generation Facilities Description

The generation facility for Irving Green located at 5855 East Washington Street consists of a main 77.7kW AC application value and 325 NuSun Solar NS250P-6M panels. Finalizing the interconnection agreement and qualification for Rate REP is dependent upon the Seller (customer) providing evidence of site control.

There will be one Fronius 33.3 kW Inverter and one Fronius 44.4kW Inverter both of which are 208 volt three phase 60 Hz for a total inverter generator capacity of 77.7kW and a value of 77.7kW generation capacity as listed on the September 6, 2012 application.

The two three phase Inverters are connected to a neutral deriving transformer as shown on drawing E2. This transformer will connect to a new 1000KVA 208-120/208 wye wye padmout transformer connected to the circuit feeding pole/pad FIN number 478/545-A Prospect #3 switching section 5790 as of November 27, 2012. The panel DPH will be connected to the existing service by others at existing BUYER (IPL) transformer through a revenue grade BUYER (IPL)supplied meter attached to Seller(customer) supplied disconnects on each side of the meter operated by BUYER (IPL)and maintained by the Seller(customer). The meter disconnects as shown in drawing E2 shall be supplied and maintained by the Seller(customer) and operated by BUYER (IPL)meter personnel solely as a safety measure for BUYER (IPL) meter field personnel. The meter and associated disconnects shall be mounted on an outside wall at normal working height having access from the public right of way. The electrical contractor must meet with the BUYER (IPL) meter layout technician to finalize meter installation plans and location. BUYER (IPL) requires this installation to comply with the national electric code and Seller(customer) will be responsible for that requirement.

Points of Interconnection, Disconnect and Ownership

The points of interconnection, disconnect and ownership shall be the first disconnect switch in the circuit going in the direction to the Seller(customer) from the BUYER (IPL)13.2 kV transformer number, identified in Exhibit 1A drawing E2 located on the Seller(customer)'s premise.

Interconnection Facilities shall Constructed by Producer or Owner including Revenue Metering Equipment

Revenue Metering - The Seller(customer shall install the following equipment in accordance with BUYER (IPL) specifications.

Meter base and disconnect on each side of the meter.

Meter Cabinet - 1 Cabinet for mounting revenue meter

Seller(customer) shall install all required conduit, cables electrical equipment required for this installation.

BUYER (IPL) shall provide and install the following revenue meter

One revenue meter to monitor the inverter.

The Seller(customer) shall be responsible for all metering and connection costs. Seller(customer) or Producer shall provide a deposit to Buyer (IPL) for the total estimated cost prior to Buyer (IPL) commencing installation.

Estimated Costs for the interconnection will include

SOLAR METER COSTS			
	\$726.09	\$726.09	CT Cabinet
3X	\$85.75	\$257.25	Current Transformers
	\$220.00	\$220.00	Meter
		\$1203.34	Total Meter Costs

Operating Conditions –

The Emergency Contact is _____. The building owner for the property is _____ managed by _____ management whose contact person is _____.

The installation shall operate as governed by the IEEE 1547 standard.

The distributed resource (DR) shall operate the point of common coupling at 1.0 power factor (PF unity). The DR shall be notified of any changes needed to the power factor (PF) scheduled based on testing and operating experience after commissioning.

The Seller (customer) shall notify Buyer (IPL) prior to operating the distributed generation and request a witnessing test as dictated by IEEE 1547 section 5.4 with procedures detailed in

footnote 19 stating that the test procedures are commonly provided by the equipment manufacturer(s). The Seller (customer) should have a written test procedure prior to the test which should contain check-off boxes for all actions taken during the test. Seller (customer) shall provide Buyer (IPL) a copy of the test procedure at the conclusion of the test

The Seller (customer) shall compensate Buyer (IPL) for labor and materials needed for maintenance of equipment required after interconnection. Standard labor and overtime rates shall apply for work performed. Routine work shall be scheduled at least a month in advance or performed at emergency overtime rates pending availability of crews and equipment.

Attachments

Exhibit 1A Interconnection Application dated September 6, 2012

Exhibit 1B Certificate of Liability Insurance

Exhibit 1C Drawings PV100, PV101, PV102, PV103

Exhibit 1D Drawing E1

Exhibit 1E Drawing E2

Exhibit 1F Operation Description

Exhibit 1G Interconnection Standard

Exhibit

1A Interconnection Application dated September 6, 2012



SEP 06 2012 11:07

Application For Interconnection
Level 2**- 2MW or Less

Application Date: 9/4/2012

Applicant Information (Please use the tab key between fields.)

Customer (Applicant) Name: Irvington Partners
Applicant Address: 5855 East Washington St.
City/State/Zip Code: Indianapolis, IN 46219
Contact Person: Tom Peck
Email Address: tpeck@meyer-najem.com Phone: 317-813-6233

Generation Site Information

Service (Site) Address: 5855 East Washington St.
City/State/Zip Code: Indianapolis, IN 46219
Phone Number: N/A Lat/Long: 39° 46'N 86° 03'W
Map-Pole Number: Meter No: N/A - New Construction

Developer Information

Project Developer Name: Johnson Melloh Solutions Email Address:
btitus@johnsonmelloh.com
Project Developer Address: 5925 Stockberger Place, Indianapolis, IN 46241 Phone: 317-244-5993

Please provide names and contact information for other Contractor and Engineering firms involved in the design and installation of the general facilities:

Wetzel Electrical Engineering
Michael Wetzel, PE
317-862-5137

Interconnection Information

Total Generating Capacity Output of Customer Facility (AC Power and Voltage): 77.7kW AC 208V

Type of Generator: Inverter-Based Synchronous Induction

Power Source: Solar Wind Diesel-fueled Reciprocating Engine
 Gas-Fueled Reciprocating Engine Gas Turbine Microturbine
 Other (Specify)

Is the Equipment "Certified" * as defined by 170 Indiana Administrative Code ("IAC") 4-4.3-5
 Yes No

* Certified as defined in 170 IAC 4-4.3-5
** Level 2 as defined in 170 IAC 4-4.3-4(a)



Application For Interconnection

Level 2**.. 2MW or Less

Indicate all possible operating modes for this generator facility:

- Emergency / Standby – Operated when Indianapolis Power & Light Company service is not available. Paralleling is for short durations.
- Peak Shaving -- Operated during peak demand periods. Paralleling is for extended times.
- Base Load Power – Operated continuously at a predetermined output. Paralleling is continuous.
- Cogeneration – Operated primarily to produce thermal energy. Paralleling is extended or continuous.
- Renewable non-dispatched – Operated in response to an available renewable resource such as solar or wind. Paralleling is for extended times.
- Other – Describe:

Indicate the intended use of power generated from the proposed facility, subject to all applicable regulatory approvals.

- Sale of power to IPL by Rate CGS.
- Sale of power to IPL by Rate REP.
- Net Metering
- Internal Usage only
- Demand Response Resource
- Other - Explain

Level of Interconnection Review Requested:

- Level 2** for nameplate rating 2MW or less

For this application to be considered complete, adequate documentation and information must be submitted that will allow Indianapolis Power & Light Company ("IPL") to determine the impact of the generation facilities on IPL's electric system and to confirm compliance by Customer with the provisions of 170 IAC 4-4.3 and IPL's requirements. Typically this should include the following for Level 2 applications:

1. Single-line diagram of the customer's system showing all electrical equipment from the generator to the point of interconnection with IPL's distribution system, including generators, transformers, switchgear, switches, breakers, fuses, voltage transformers, and current transformers.
2. Control drawings for relays and breakers.
3. Site Plans showing the physical location of major equipment.

* Certified as defined in 170 IAC 4-4.3-5

** Level 2 as defined in 170 IAC 4-4.3-4(a)



Application For Interconnection

Level 2**- 2MW or Less

4. Relevant ratings of equipment. Transformer information should include capacity ratings, voltage ratings, winding arrangements, and impedance.
5. If protective relays are used, settings applicable to the interconnection protection. If programmable relays are used, a description of how the relay is programmed to operate as applicable to interconnection protection.
6. For Certified* equipment, documentation confirming that a nationally recognized testing and certification laboratory has listed the equipment.
7. A description of how the generator system will be operated including all modes of operation.
8. For inverters, the manufacturer name, model number, and AC power rating, Operating manual or link to manufacture's web site containing such manual.
9. For synchronous generators, manufacturer and model number, nameplate ratings, and impedance data (X_d , X'_d , & X''_d).
10. For induction generators, manufacturer and model number, nameplate ratings, and locked rotor current.

This application is subject to further consideration and study by IPL and the possible need for additional documentation and information from Customer.

Fees

Level 2 Initial Review \$50 plus, \$1/kW of nameplate capacity.
Additional Review¹ Non-binding, good faith cost estimate provided to customer.

¹ Additional Review may be elected by the customer for the case where the facility failed to meet one or more of the applicable requirements and the Initial Review indicated that additional review may enable the Company to approve the application with minor modifications. The applicant cost to conduct the Additional Review is in addition to the initial Review Fee. Actual costs will be billed or credited to the applicant following completion of the Additional review and minor modifications.

Insurance Requirements

The Applicant shall provide evidence of homeowners, commercial or other insurance that provides coverage in the amount of at least \$2 million for Comprehensive General Liability and Contractual Liability.

Evidence of Insurance coverage provided with Application

Reference Documents

170 IAC Customer generator interconnection standards are located at the following web site. <http://www.in.gov/legislative/iac/101700/A00040.PDF> ?

Submittal of Fees, Application and Documentation

Fees - Payment for the Initial Review shall be sent to IPL Distributed Generation Interconnections, Attn: Sonya Kunkel, 1230 W Morris St., Indianapolis, IN 46221. Please make checks payable to Indianapolis Power & Light Co. and include the customer's name and address on the check.

* Certified as defined in 170 IAC 4-4.3-5

** Level 2 as defined in 170 IAC 4-4.3-4(a)

07-08-2011

Exhibit 1C Drawings PV100, PV101, PV102, PV103

Solar Array for IRVING GREEN

5855 East Washington Street
 Indianapolis, IN



VICINITY MAP
 No Scale

DRAWING INDEX

- PV100 Title Sheet
- PV101 Plans and Details
- PV102 DC Side Riser Diagram
- PV103 Product Data Sheets

- E1 AC Side Electrical Plan
- E2 AC Side Electrical Diagram

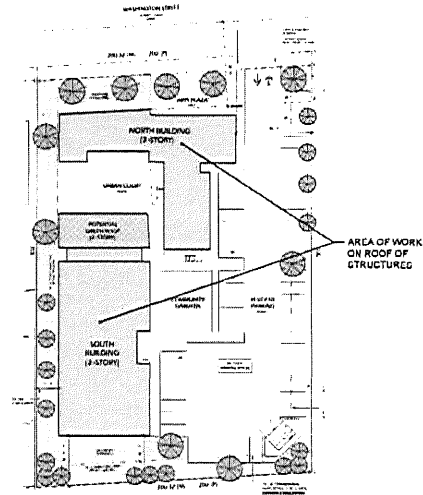

SITE PLAN
 1" = 10'



5925 Stockberger Place
 Indianapolis, IN 46241
 317-244-5993

Project No: DG00-1000-0202
 Design For: MFIRG
 Drawn By: TMK

Date	Description
ASB-G	ISSUED FOR INTERCONNECTION

These drawings and specifications, and all parts hereof, are not valid unless signed and sealed by the Engineer. They shall be used only for the project and for the purpose for which they were prepared. They are to be returned to the Engineer upon completion of the project. They are to be kept in a safe place and not to be loaned, copied, or otherwise used without the written consent of the Engineer.



Solar Array for
IRVING GREEN
 5855 East Washington Street
 Indianapolis, Indiana

TITLE SHEET

PV100

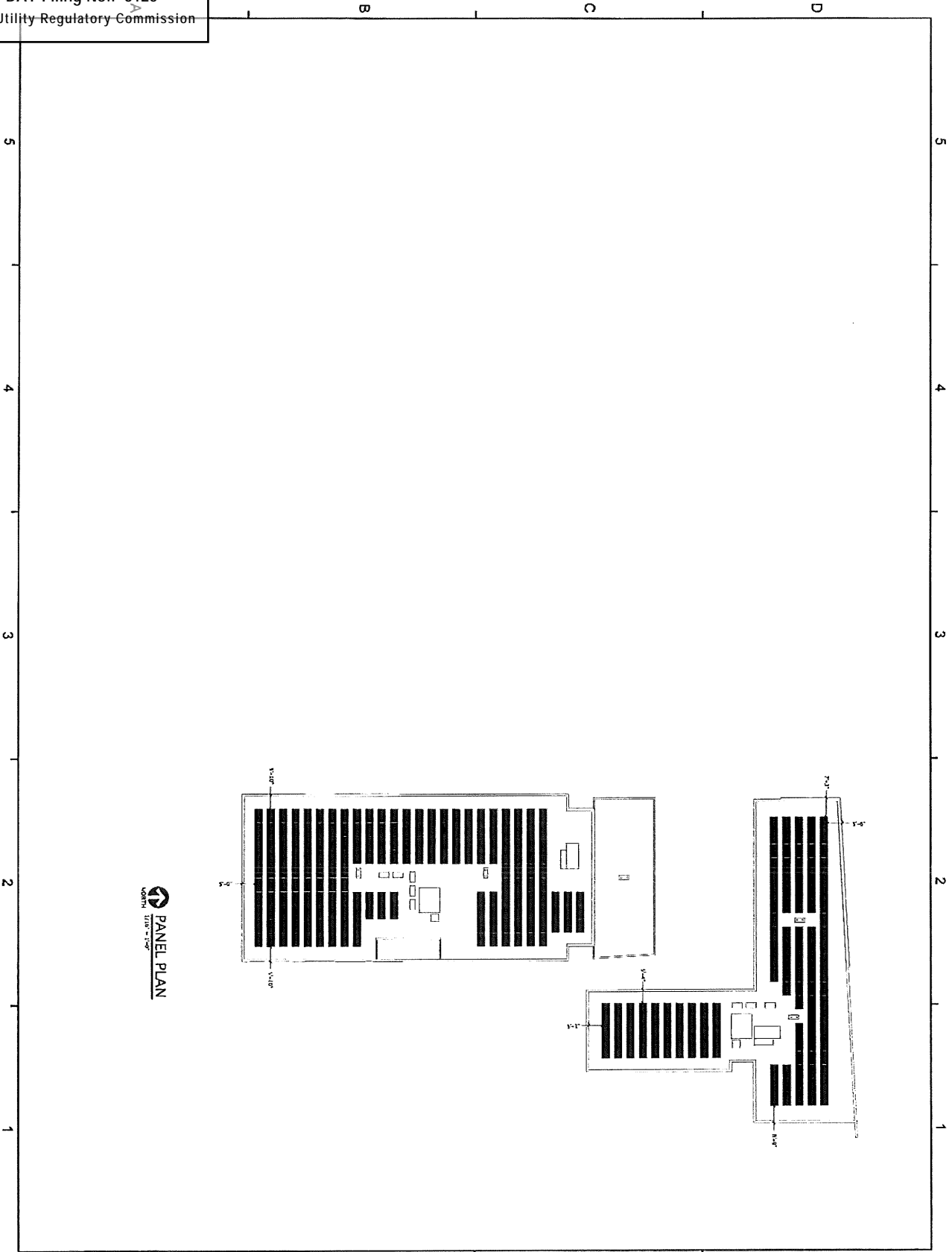

PV101

Plan and
 Details

Solar Array for
IRVING GREEN
 5855 East Washington Street
 Indianapolis, Indiana

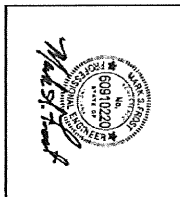

Project No: 0500-1008-002
 Design by: JES/BC
 Drawn by: TJK
 Date: _____
 Scale: _____
 THIS DRAWING IS THE PROPERTY OF THE ENGINEER. IT IS TO BE USED ONLY FOR THE PROJECT AND SITE SPECIFICALLY IDENTIFIED HEREON. IT IS NOT TO BE REPRODUCED OR TRANSMITTED IN ANY FORM OR BY ANY MEANS, ELECTRONIC OR MECHANICAL, INCLUDING PHOTOCOPYING, RECORDING, OR BY ANY INFORMATION STORAGE AND RETRIEVAL SYSTEM, WITHOUT THE WRITTEN PERMISSION OF THE ENGINEER.

FORNBERG ENGINEERS
 5925 Stockbarger Place
 Indianapolis, IN 46241
 317-244-5993

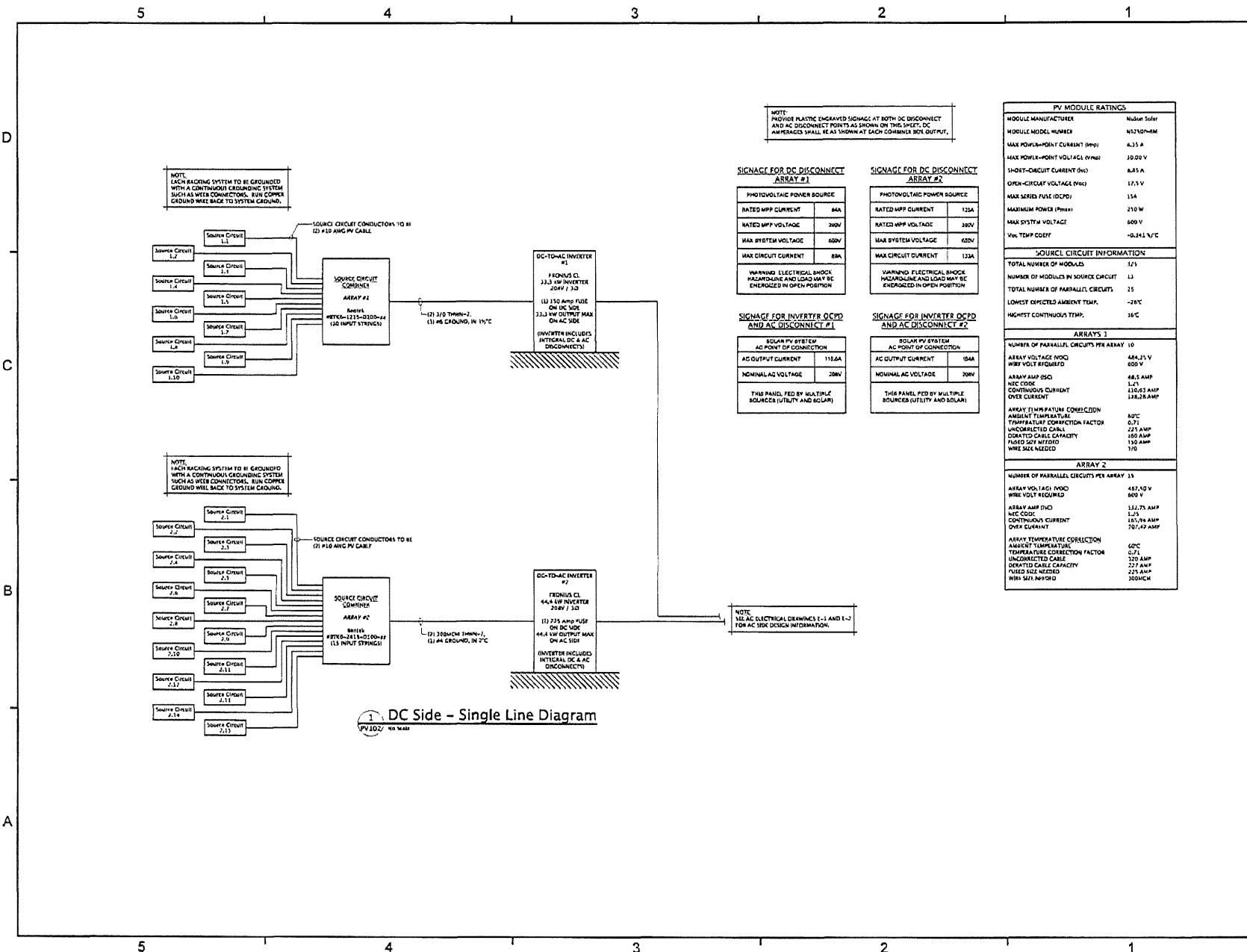

SIGNAGE FOR DC DISCONNECT ARRAY #1

PHOTOVOLTAIC POWER SOURCE	84A
RATED MPP CURRENT	84A
RATED MPP VOLTAGE	300V
MAX SYSTEM VOLTAGE	600V
MAX CIRCUIT CURRENT	84A

SIGNAGE FOR DC DISCONNECT ARRAY #2

PHOTOVOLTAIC POWER SOURCE	123A
RATED MPP CURRENT	123A
RATED MPP VOLTAGE	300V
MAX SYSTEM VOLTAGE	600V
MAX CIRCUIT CURRENT	123A

SIGNAGE FOR INVERTER OCPD AND AC DISCONNECT #1

SOLAR PV SYSTEM AC POINT OF CONNECTION	113.6A
AC OUTPUT CURRENT	113.6A
NOMINAL AC VOLTAGE	208V

SIGNAGE FOR INVERTER OCPD AND AC DISCONNECT #2

SOLAR PV SYSTEM AC POINT OF CONNECTION	154A
AC OUTPUT CURRENT	154A
NOMINAL AC VOLTAGE	208V

PV MODULE RATINGS

MODULE MANUFACTURER	Module Solar
MODULE MODEL NUMBER	M52V0-6MM
MAX POWER-POINT CURRENT (Imp)	4.35 A
MAX POWER-POINT VOLTAGE (Vmp)	30.00 V
SHORT-CIRCUIT CURRENT (Isc)	6.81 A
OPEN-CIRCUIT VOLTAGE (Voc)	17.1 V
MAX SERIES FUSE (DC/DC)	15A
MAXIMUM POWER (Pmax)	210 W
MAX SYSTEM VOLTAGE	600 V
Voc TEMP COEFF	-0.241 %/°C

SOURCE CIRCUIT INFORMATION

TOTAL NUMBER OF MODULES	30
NUMBER OF MODULES IN SOURCE CIRCUIT	10
TOTAL NUMBER OF PARALLEL CIRCUITS	25
LOWEST EXPECTED AMBIENT TEMP.	-20°C
HIGHEST CONTINUOUS TEMP.	35°C

ARRAYS 1

NUMBER OF PARALLEL CIRCUITS PER ARRAY	10
ARRAY VOLTAGE (Voc)	482.1 V
WIRE VOLT REQUIRED	600 V
ARRAY AMP (Isc)	48.1 AMP
NCC CODE	L-2
CONTINUOUS CURRENT OVER CURRENT	148.28 AMP
ARRAY TEMPERATURE CORRECTION	0.71
AMBIENT TEMPERATURE	60°C
TEMPERATURE CORRECTION FACTOR	0.71
UNCONNECTED CABLE	225 AMP
DERATED CABLE CAPACITY	180 AMP
FUSED SIZE NEEDED	150 AMP
WIRE SIZE NEEDED	110

ARRAY 2

NUMBER OF PARALLEL CIRCUITS PER ARRAY	13
ARRAY VOLTAGE (Voc)	482.1 V
WIRE VOLT REQUIRED	600 V
ARRAY AMP (Isc)	53.73 AMP
NCC CODE	L-2
CONTINUOUS CURRENT OVER CURRENT	167.98 AMP
ARRAY TEMPERATURE CORRECTION	0.71
AMBIENT TEMPERATURE	60°C
TEMPERATURE CORRECTION FACTOR	0.71
UNCONNECTED CABLE	320 AMP
DERATED CABLE CAPACITY	227 AMP
FUSED SIZE NEEDED	225 AMP
WIRE SIZE NEEDED	100MCM

JOHNSON MELLAN SOLUTIONS
 5925 Stockberger Place
 Indianapolis, IN 46241
 317-244-5993

Project No: 0200-1000-0202
 Design By: MFRG
 Drawn By: TMK

Date	Description
03/15/12	ISSUED FOR INTERCONNECTION

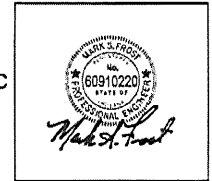

Solar Array for
IRVING GREEN
 5855 East Washington Street
 Indianapolis, Indiana

DC Side Diagrams

PV102

Exhibit 1 D Drawing E1

5 4 3 2 1

COMPLETE INSTALLATION SHALL COMPLY WITH NEC, IEEE/ANSI AND RELATED NEC SECTIONS. E.C. SHALL BE HIGHLY FAMILIAR WITH THESE SECTIONS. NOT LIMITED TO LABELING ALL EQUIPMENT, CIRCUITING, BONDING, ETC.

CONNECT/CARRY INVERTER GROUND TO DISCONNECT AND TO AC SYSTEM GROUND CONDUIT SIZE #8

INVERTER DATA	
DESCRIPTION	
FRONIUS USA LLC	CL 33.3 DELTA
CONTINUOUS OUTPUT POWER	33.3 KW
MAXIMUM DC INPUT VOLTAGE	800
DC MP NOMINAL CURRENT	80.8 A
AC NOMINAL VOLTAGE	208 V
AC OPERATING RANGE	183-239
AC FREQUENCY RANGE	59.3-60.5 HZ
AC MAXIMUM CONTINUOUS CURRENT	82.4 A
HARMONIC DISTORTION (KTHD)	<3
POWER FACTOR	> .99
MOUNTING	PAD MOUNT
WEIGHT	861 LBS.
ISOLATION PROTECTION	YES
DIMENSIONS	43.5"W X 78.6"H X 31.4"D
DISCONNECTS	AC & DC DISCONNECTS

INVERTER DATA	
DESCRIPTION	
FRONIUS USA LLC	CL 44.4 DELTA
CONTINUOUS OUTPUT POWER	44.4 KW
MAXIMUM DC INPUT VOLTAGE	800
DC MP NOMINAL CURRENT	121.1 A
AC NOMINAL VOLTAGE	208 V
AC OPERATING RANGE	183-239
AC FREQUENCY RANGE	59.3-60.5 HZ
AC MAXIMUM CONTINUOUS CURRENT	123.2 A
HARMONIC DISTORTION (KTHD)	<3
POWER FACTOR	> .99
MOUNTING	PAD MOUNT
WEIGHT	721 LBS.
ISOLATION PROTECTION	YES
DIMENSIONS	43.5"W X 78.6"H X 31.4"D
DISCONNECTS	AC & DC DISCONNECTS

SPECIFICATIONS

1. ALL WORK SHALL BE DONE IN STRICT ACCORDANCE WITH ALL LOCAL COUNTY AND STATE CODES, APPLICABLE LAWS, RULES AND REGULATIONS GOVERNING THE INSTALLATION OF THE ELECTRICAL SYSTEM. THE OWNER SHALL OBTAIN AND PAY ALL PERMITS, LICENSES AND INSPECTION FEES AS REQUIRED FOR THE INSTALLATION OF ALL ELECTRICAL WORK.
2. ALL MATERIAL AND INSTALLATION SHALL BE FIRST-CLASS IN EVERY RESPECT. INSTALLATION SHALL BE DONE IN A SUBSTANTIAL AND WORKMANLIKE MANNER.
3. ALL EQUIPMENT SHALL BE UL APPROVED.
4. A GREEN GROUND WIRE SHALL BE USED IN ALL CONDUIT.
5. ALL WIRING SHALL BE IN ACCORDANCE WITH THE LATEST NEC.

WASHINGTON STREET

GENERAL NOTES

SEE SINGLE LINE DIAGRAM SHEET E2

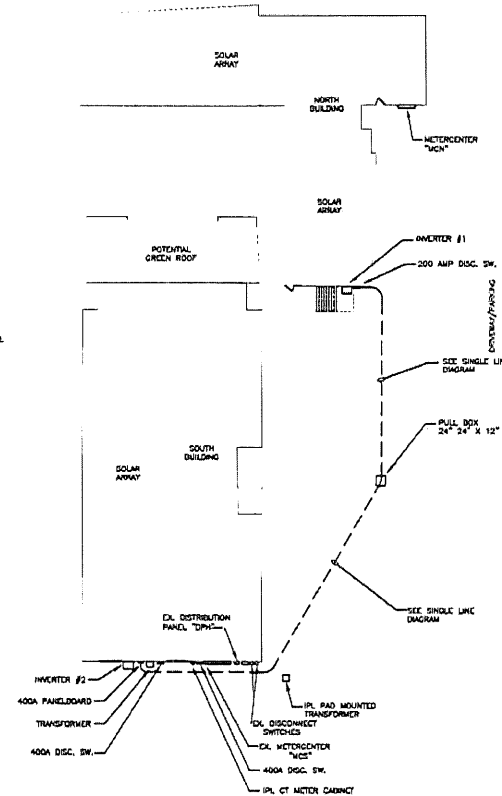
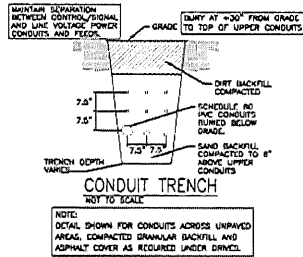

ELECTRICAL SITE PLAN
SCALE 1" = 20'



5 4 3 2 1



5925 Stockberger Place
 Indianapolis, IN 46241
 317-244-5993

Placed On: _____
 Project Date: _____
 Prepared By: _____
 Revision Date: _____

Please printing and distribution, use of this drawing on any other project without the approval of the engineer is prohibited. Please do not use this drawing for any other project without the approval of the engineer. Project of work shall not be undertaken without the approval of the engineer.



Solar Array for
5855 East Washington St.
 5855 E. Washington St.
 Indianapolis, Indiana 46219

ELECTRICAL SITE PLAN

E1

Exhibit 1E Drawing E2

5 4 3 2 1

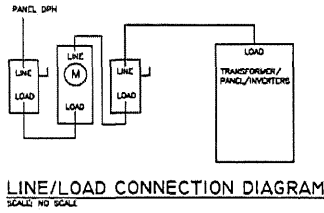

COMPLETE INSTALLATION SHALL COMPLY WITH NEC 910 AND RELATED NEC SECTIONS. E.C. SHALL BE HIGHLY FAMILIAR WITH THIS SECTION. NOT LIMITED TO LANDING ALL EQUIPMENT, GROUNDING, BONDING, ETC.

CONNECT/CARRY INVERTER GROUND TO DISCONNECT AND TO AC SYSTEM GROUND CONDUCTOR SIZE #8.

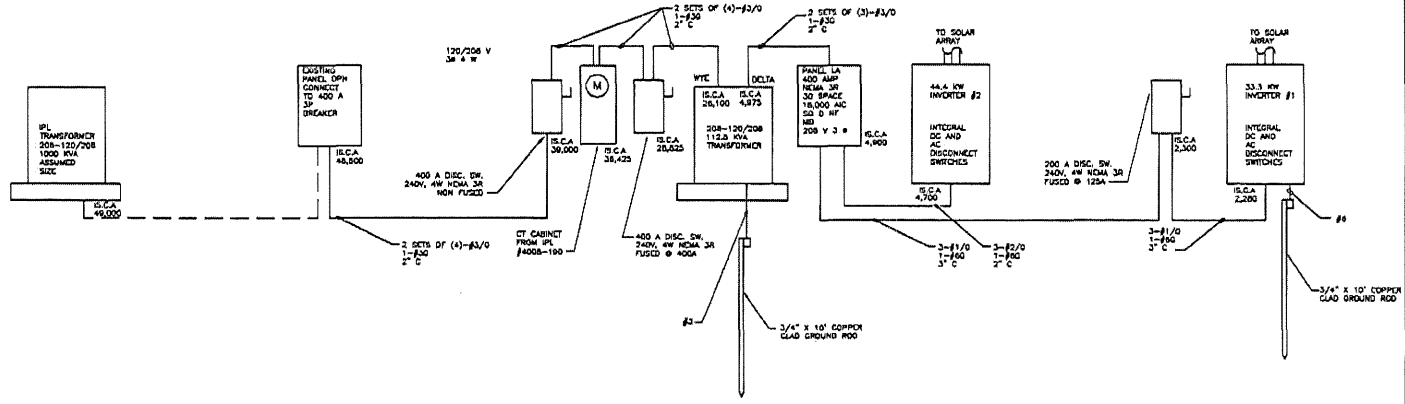

PANEL SCHEDULE		DESIGNATION LA	LOCATION EQUIP RACK	MAINS	400A M.B.
Ckt No	CIRCUIT DESCRIPTION	WIRE	VOLTAGE	PHASE	SURFACE
1	INVERTER #1	AS SHOWN	120	3	RECESSED
3	INVERTER #2	AS SHOWN	120	3	RECESSED
7	BLANK				
9					
11					
13					
15					
17					
19					
21					
23					
25					
27					
29					
		25.9	25.8	25.0	
		77.7 KW			

SINGLE LINE DIAGRAM
 SCALE: NO SCALE

5 4 3 2 1

ROBINSON DESIGN SOLUTIONS
 5925 Stockberger Place
 Indianapolis, IN 46241
 317-244-5993

Project No. _____
 Project Date _____
 Projected _____
 Revision Date _____

These drawings are the property of Robinson Design Solutions. They shall be used only for the project and site specified on these drawings. They shall not be used for any other project without the written permission of Robinson Design Solutions.

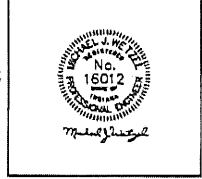

Solar Array for
5855 East Washington St.
 5855 E. Washington St.
 Indianapolis, Indiana 46219

ELECTRICAL WIRING DIAGRAM

E2

September 4, 2012

Indianapolis Power and Light
Attn: Ron Cooper
1230 W. Morris Street
Indianapolis, Indiana 46221

Irving Green 77.7kW Solar Array
5855 East Washington Street
Indianapolis, IN 46219

Description of Operation:

Mark III Management will ultimately be responsible for the inverters operation. Contact Chuck Pechette at Mark III Management (317) 863-3133 (M3M). IPL shall contact M3M for inverter switching operations, if needed. There will be 7 day a week operation and maintenance of the equipment, as needed. Since the solar equipment can only operate during daylight, 24-hour a day operation and maintenance will not be necessary. The equipment will be monitored remotely (internet based), but will only be manually operated on-site.

If there is a fire call, the first step is to call 911. If safe (away from fire hazard), the second step should be to flip the inverter AC breaker at the Solar Electrical Panel. By doing this, it will eliminate the grid AC power to the inverter, which in turn automatically shuts down the inverter, per its UL 1741 listing. However, an alternative to flipping the breaker is to open one of the AC disconnects located on either side of the revenue meter on the outside of the building. This will create the same effect of shutting down the inverter via its loss of grid AC power. The inverter itself contains both integrated AC and DC disconnects for additional disconnecting means.

Normal daily startup and shutdown of the system is fully automatic. Any intentional shut downs will be performed manually by first opening the DC disconnect on the inverter, and then the AC disconnect on the inverter. To restart after intentional shut down, the AC disconnect shall be closed first, followed by the DC disconnect. Remote operation will not be a feature of this system.

Sincerely,

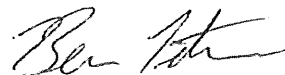

Ben Titus
Project Manager
Johnson Melloh Solutions



ALL RENEWABLE ENERGY GENERATORS LESS THAN 500KVA WITH SECONDARY 208V Y OR 480V Y INTERCONNECTIONS MUST HAVE AN IPL CONTROLLED MANUAL DISCONNECT, METER POINT AND CUSTOMER CONTROLLED DISCONNECT BREAKER.

SEE ELECTRIC SERVICE AND METER MANUAL SECTION 175

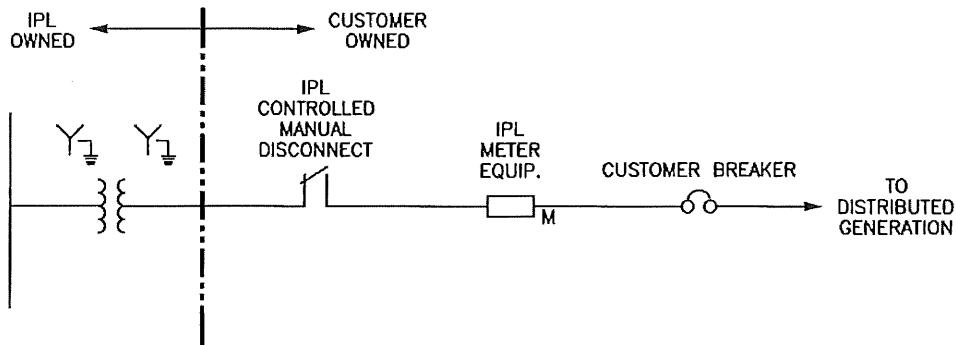

UNDERGROUND/OVERHEAD SINGLE LINE DIAGRAM

NOTES:

1. ANY DISTRIBUTED GENERATION INTERCONNECTION GREATER THAN 1500KVA MUST BE CONNECTED AT PRIMARY VOLTAGE LEVEL.
2. NO DISTRIBUTED GENERATION INTERCONNECTION SHALL BE MADE TO DELTA CONNECTED SECONDARY TRANSFORMER CONFIGURATIONS.
3. THE TRANSFORMER, ASSOCIATED LINES AND COMMUNICATIONS DEVICES, SPECIFICALLY FOR SOLAR GENERATION, WILL BE LEASED TO THE CUSTOMER.

**208V OR 480V 3-PHASE
SECONDARY DISTRIBUTION
INTERCONNECTION ONE-LINE
LESS THAN 500KVA**

EXHIBIT B

CONSENT AND AGREEMENT FOR THE BENEFIT OF THE FINANCING PARTIES

This CONSENT AND AGREEMENT FOR THE BENEFIT OF THE FINANCING PARTIES, (this "Consent") dated _____, 201_, is by and among Indianapolis Power & Light Company, an Indiana corporation ("Company"), _____ ("Financing Party") _____ and a _____ ("Seller").

Reference is made to the Power Purchase Agreement for Qualifying Renewable Energy Production Facilities dated [____], 2013 (the "Agreement"). Capitalized terms used herein but not defined herein shall have the meanings set forth in the Agreement.

RECITALS

A. Seller has entered into that certain [Financing Agreement] dated as of _____, 201_ (the "Financing Agreement") by and among Seller and the financial institutions party thereto (the "Financing Parties") pursuant to which the Financing Parties have agreed to make certain credit facilities available to Seller;

B. As security for the "Obligations" as such term is defined in the Financing Agreement and excluding for the avoidance of doubt any obligations with respect to any other power project other than the Facility (the "Secured Obligations"), Seller will enter into a Security Agreement ("Security Agreement") pursuant to which Seller will assign all of its right, title and interest in, to and under the Agreement to the Financing Parties. The Security Agreement and any other related agreements, security documents and financing documents are referred to hereinafter as the "Financing Documents."

NOW THEREFORE, in consideration of the foregoing, and for other good and valuable consideration, the receipt and adequacy of which are hereby acknowledged, and intending to be legally bound, the parties hereto hereby agree as follows:

1. Consent to Collateral Assignment. Company consents to the assignment by Seller to one or more Financing Parties that has provided financing of the Facility, of Seller's right, title and interest in and to the Agreement (the "Assigned Rights") as security for the performance of the Secured Obligations. Company further consents to the subsequent transfer of the Assigned Rights to any person in connection with the exercise by the Financing Party of its rights and remedies under the Financing Documents following the occurrence of an event of default thereunder (any person to whom an assignment may be made pursuant to this Section (a), a "Transferee").

2. Rights Upon Event of Default under Financing Documents. Company hereby acknowledges and agrees, notwithstanding anything to the contrary contained in the Agreement, that none of the following shall constitute, as between Company and the Financing Party, a default by the Seller under the Agreement or shall result in a termination thereof, so long as all the duties and obligations of the Seller are being performed in accordance with the terms thereof:

- a. the assignment of the Agreement to the Financing Party or to a Transferee;

- b. the Financing Party's or Transferee's actions to foreclose its security interest in the Agreement or any other assets of the Seller, including the Facility, and to take possession of and operate the Facility or any portion thereof and to perform all obligations to be performed by the Seller under the Agreement; and
- c. the Financing Party's or Transferee's acquisition of the Agreement or any other assets of the Seller, including the Facility, by an assignment as authorized under the Financing Documents following the occurrence of an event of default thereunder and the subsequent assignment or transfer of the Agreement or any other assets of the Seller, including the Facility, to a third party in connection with any sale of the Facility, pursuant to the terms of this Consent, provided that each such person or Transferee, pays all amounts due and owing to Company and assumes and agrees to perform all of the Seller's obligations under the Agreement, both prospective and accrued, including the obligation to cure any then existing defaults capable of cure by performance or the payment of money damages, subject to the terms and conditions of the Agreement. The Financing Party shall provide Company with prior written notice of any assignment of the Agreement permitted by Section 2(a).

3. Notices of Default. Company shall deliver to the Financing Parties, concurrently with delivery to Seller, a copy of each notice of Seller Default, if any, given by Company under the Agreement, inclusive of a reasonable description of Seller Default, if any. No such notice will be effective absent delivery to the Financing Parties. Absent a Seller Default, Company will not mutually agree with Seller to terminate the Agreement without the written consent of the Financing Parties.

4. Right to Cure. Company will not exercise any right to terminate or suspend the Agreement unless it shall have given the Financing Party prior written notice by sending notice to the Financing Party (at the addresses provided to Company by Seller within one hundred-twenty (120) days after the Effective Date, as defined in the General Terms and Conditions of the Power Purchase Agreement) of its intent to terminate or suspend this Agreement, specifying the condition giving rise to such right, and the Financing Party shall not have caused to be cured the condition giving rise to the right of termination or suspension within thirty (30) days after such notice or (if longer) the periods provided for in this Agreement. The Financing Parties shall have the right, but not the obligation, to pay all sums due under the Agreement and to perform any other act, duty or obligation required of Seller thereunder or cause to be cured any default of Seller thereunder in the time and manner provided by the terms of the Agreement. Nothing herein requires a Financing Party to cure any default of Seller under the Agreement or (unless and until such Financing Party or the Transferee has succeeded to Seller's interests under this Agreement) to perform any act, duty or obligation of Seller under the Agreement, but Company hereby gives the Financing Parties the option to do so. The Parties' respective obligations will otherwise remain in effect during any cure period; provided that if such Seller Default cannot reasonably be cured by a Financing Party within such period and such Financing Party commences and continuously pursues cure of such default within such period, such period for cure will be extended for a reasonable period of time under the circumstances, such period not to exceed an additional ninety (90) days.

If a Financing Party (including any Transferee), pursuant to an exercise of remedies by such Financing Party under the Financing Documents, shall acquire title to or control of Seller's assets and shall, within the time periods described above, cure all Seller Defaults under the Agreement existing as of the date of such change in title or control in the manner required by the Agreement and which are capable of cure by a third person or entity, then such person or entity shall no longer be in default under the Agreement, and the Agreement shall continue in full force and effect.

5. No Company Liability on Debt. Nothing herein shall be deemed to make Company responsible or liable for any obligations of Seller pursuant to the Financing Documents (including, without limitation, any repayment obligations for amounts borrowed under the Financing Agreement and any indemnity obligation under the Financing Documents), and Company's execution of this Consent and Agreement shall not be deemed an assumption of any of Seller's obligations thereunder.

6. No Default. Company represents and warrants to the Financing Parties that neither Company nor, to the actual knowledge of Company, Seller, is in default of any of its obligations under the Agreement. To the actual knowledge of Company, after giving effect to the consent to such assignment by Company contained herein, there exists no event or condition which would, either immediately or with the passage of time or giving of notice, or both, enable either Company or Seller to excuse, terminate or suspend its obligations under the Agreement.

7. Performance of Obligations. During any period of possession of the Facility by the Financing Party or its Transferee and/or during the pendency of any foreclosure proceedings instituted by the Financing Party or its Transferee, the Financing Party or its Transferee shall perform or cause to be performed all duties and obligations of the Seller under the Agreement. Following acquisition of the Facility by the Financing Party or its Transferee as a result of either foreclosure or acceptance of an assignment in lieu of foreclosure, or by a purchaser at a foreclosure sale, the Financing Party or its Transferee shall assume the obligations of the Seller under the Agreement, the Agreement shall remain in full force and effect and the Financing Party or its Transferee or party acquiring title to the Seller's interest in the Agreement shall immediately cure all monetary defaults of the Seller under the Agreement and shall, as promptly as reasonably possible, commence the cure of all defaults thereunder and thereafter diligently process such cure to completion.

8. New Agreement. Upon any rejection or other termination of the Agreement pursuant to any process undertaken with respect to Seller under the United States Bankruptcy Code, at the request of a Financing Party made within ninety (90) days of such termination or rejection, Company shall enter into a new agreement (the "New Agreement") with such Financing Party or its assignee having the same terms and conditions as the Agreement. The Financing Party or its Transferee shall pay to Company all monetary charges payable by the Seller under the terms of the Agreement up to the date of execution of the New Agreement, as if the Agreement had not been terminated, foreclosed, rejected or disaffirmed, less collections by Company, if any, from the Seller. The Financing Party or its Transferee shall perform all other obligations of the Seller under the terms of the Agreement, to the extent performance is then due and susceptible of being cured and performed by the Financing Party or its Transferee on or before the date of the New Agreement. The Financing Party or its Transferee shall agree in writing to perform, or cause to be performed within thirty (30) days of the date of the New Agreement, all other non-monetary

obligations which have not been performed by the Seller and would have accrued under the Agreement up to the date of commencement of the New Agreement. The Seller hereby acknowledges and hereby declares for the benefit of the Company and the Financing Party that any New Agreement shall be free of any and all rights of the Seller.

9. Notices. All notices and other communications provided by Company to the Financing Party or a Transferee shall be delivered in writing concurrently with delivery thereof to the Seller. All notices provided to any party pursuant to this Consent shall be in writing or by facsimile, shall refer on their face to the Agreement (although failure to so refer shall not render any such notice or communication ineffective), and addressed, delivered or transmitted to such party at its address or facsimile number set forth below its signature hereto or at such other address or facsimile number as may be designated by such party in a notice to the other parties. Any notice, if mailed and properly addressed with postage prepaid, or if properly addressed and sent by prepaid courier service, shall be deemed given when received; any notice, if transmitted by facsimile, shall be deemed given when transmitted.

10. No Waiver. Nothing contained in this Consent shall be deemed to constitute a waiver or release by Company of (i) Company's right to terminate (A) the Agreement and/or (B) the rights of the Financing Party (or its Transferee) under this Consent, or Company's right to recover damages, in the event that the Financing Party (or its Transferee) breaches or in any manner defaults under the terms of the Agreement (after express assumption by any such party of the Seller's interest in the Agreement) or any New Agreement; or (ii) any right of Company to seek specific performance of any obligation owing to Company under the Agreement or this Consent.

11. Legal Opinion. Upon the request of the Financing Party (or its Transferee), Company shall deliver legal opinions relating to the due authorization, execution and delivery by Company of the Agreement, this Consent, and their enforceability against Company, and relating to no violations or conflicts with other documents or laws, no consents or waivers, no litigation, and Company's organization, which legal opinions shall be in form reasonably satisfactory to the Financing Party (or its Transferee). Seller and Financing Parties shall reimburse Company for the reasonable costs of any direct out of pocket expenses (including reasonable fees and expenses of outside counsel) incurred by Company in the preparation, negotiation, execution and delivery of any documents requested by Seller or Financing Party requested under this Section.

12. Miscellaneous.

1. Separate Counterparts; Amendments, Waiver. This Consent may be executed in separate counterparts, each of which when so executed and delivered shall be an original but all such counterparts shall constitute one and the same instrument. Neither this Consent nor any of the terms hereof may be terminated, amended, supplemented, waived or modified except by an instrument in writing signed by each of Company, the Seller, and the Financing Party (or its Transferee), as the case may be.

2. Severability of Provisions. Any provision of this Consent which is prohibited or unenforceable in any jurisdiction shall, as to such jurisdiction, be ineffective to the extent of such prohibition or unenforceability without

invalidating the remaining provisions hereof, and any such prohibition or unenforceability in any jurisdiction shall not invalidate or render unenforceable such provision in any other jurisdiction.

3. Successors and Assigns. This Consent shall be binding upon and shall inure to the benefit of each of the parties hereto and its permitted successors and assigns.

4. Governing Law. THIS CONSENT SHALL IN ALL RESPECTS BE GOVERNED BY, AND CONSTRUED IN ACCORDANCE WITH, THE LAWS OF THE STATE OF INDIANA, INCLUDING ALL MATTERS OF CONSTRUCTION, VALIDITY AND PERFORMANCE.

5. Waiver of Jury Trial. COMPANY, THE SELLER AND THE FINANCING PARTY HEREBY KNOWINGLY, VOLUNTARILY AND INTENTIONALLY WAIVE ANY RIGHTS THEY MAY HAVE TO A TRIAL BY JURY IN RESPECT OF ANY LITIGATION BASED HEREON, OR ARISING OUT OF, UNDER, OR IN CONNECTION WITH, THIS CONSENT OR THE ASSIGNED AGREEMENT, OR ANY COURSE OF CONDUCT, COURSE OF DEALING, STATEMENTS (WHETHER ORAL OR WRITTEN) OR ACTIONS OF COMPANY, THE SELLER OR THE FINANCING PARTY.

6. Headings Descriptive. The headings of the several sections and subsections, of this Consent are inserted for convenience only and shall not in any way affect the meaning or construction of any provision of this Consent.

7. Entire Agreement. This Consent and any agreement, document, or instrument attached hereto or referred to herein integrate all the terms and conditions mentioned herein or incidental hereto and supersede all oral negotiations and prior writings in respect to the subject matter hereof. In the event of any conflict between the terms, conditions and provisions of this Consent and any such agreement, document or instrument, the terms, conditions and provisions of this Consent shall prevail.

8. No Third Party Beneficiaries; Further Assurances. This Consent shall be for the sole benefit of the parties hereto and their respective successors and assigns. Upon the request of the Financing Party (or its Transferee), Company agrees to execute and deliver all such instruments reasonably acceptable to Company and take all such action reasonably acceptable to Company as may be necessary to effectuate fully the purposes of this Consent.

IN WITNESS WHEREOF, the parties hereto have caused this Consent to be executed by their respective officers thereunto duly authorized as of the day and year first above written.

INDIANAPOLIS POWER & LIGHT COMPANY

By:
Name:
Title:

Address:

Facsimile No.:
Attention:

[Financing Party]

By: _____
Name:
Title:

By: _____
Name:
Title:

Address:

Facsimile No.:
Attention:

Seller

By: _____
Name:
Title:

Address:

Facsimile No.:
Attn:

Verified Statement of Indianapolis Power & Light Company (IPL)

**Concerning a Power Purchase Agreement for Qualifying Renewable Energy Power
Production between 5585 LP and IPL**

Indianapolis Power & Light Company complied with the Notice Requirements under 170 IAC 1-6-6 in the following manner:

- beginning on February 14, 2013 and continuing through the filing date, the attached notice was posted in the Customer Service Office at 2102 N. Illinois Street
- beginning on February 14, 2013 and continuing through the filing date, the same notice was posted on IPL's website under the Pending section of the Rates, Rules and Regulations area
- a legal notice placed in the Indianapolis Star on, February 14, 2013 as evidenced by the attached Publishers Affidavit; and
- beginning on the filing date, a copy of the Power Purchase Agreement for Qualifying Renewable Energy Power Production between 5585 LP and IPL 30 day filing will be included on IPL's website under the Pending section of the Rates, Rules and Regulations area.

I affirm under penalties for perjury that the foregoing representations are true to the best of my knowledge, information, and belief.

Dated this 20th day of February, 2013.

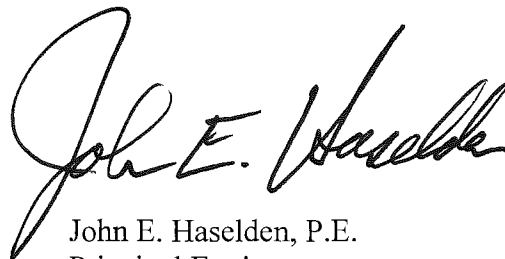

John E. Haselden, P.E.
Principal Engineer

83633-6037885

LEGAL NOTICE

Notice is hereby given that on or about February 20, 2013, Indianapolis Power & Light Company expects to submit a Power Purchase Agreement for Qualifying Renewable Energy Power Production between Grocers Supply, Inc., SEC MC Solar LLC and IPL dated February, 2013.

In addition, notice is hereby given that on or about February 20, 2013, Indianapolis Power & Light Company expects to submit a Power Purchase Agreement for Qualifying Renewable Energy Power Production between DEEM, LLC SEC MC Solar One, LLC and IPL dated February, 2013.

In addition, notice is hereby given that on or about February 20, 2013, Indianapolis Power & Light Company expects to submit a Power Purchase Agreement for Qualifying Renewable Energy Power Production between Indy Southside Sports Academy, Inc., SolScient Energy, LLC and IPL dated February, 2013.

In addition, notice is hereby given that on or about February 20, 2013, Indianapolis Power & Light Company expects to submit a Power Purchase Agreement for Qualifying Renewable Energy Power Production between Goodwill Industries of Central Indiana, Inc., 8345 Georgetown Road Solar I, LLC and IPL dated February, 2013.

In addition, notice is hereby given that on or about February 20, 2013, Indianapolis Power & Light Company expects to submit a Power Purchase Agreement for Qualifying Renewable Energy Power Production between the Trustees of Indiana University and IPL dated December 11, 2012.

In addition, notice is hereby given that on or about February 20, 2013, Indianapolis Power & Light Company expects to submit a Power Purchase Agreement for Qualifying Renewable Energy Power Production between 5855 LP and IPL dated February, 2013.

The Commission approved IPL's Rate REP (Renewable Energy Production) in its Order dated February 10, 2010 in Cause No. 43623 (Phase 1), and approved further modifications to Rate REP in its Order dated March 7, 2012 in Cause 44018, which authorized the long-term contracting of Qualifying Renewable Energy Power Production for up to fifteen (15) years subject to Commission approval of each contract. IPL anticipates approval of the filings on or before March 6, 2013.

This notice is provided to the public pursuant to 170 IAC 1-6-5. The contact information, to which an objection should be made, is as follows:

Secretary
Indiana Utility Regulatory Commission
101 W. Washington Street, Suite 1500 East
Indianapolis, Indiana 46204
Telephone:(317) 232-2700
Fax: (317) 232-6758
Email: info@iurc.in.gov
Office of Utility Consumer Counselor
115 W. Washington Street, Suite 1500 South
Indianapolis, Indiana 46204
Telephone:(317) 232-2484
Toll Free: 1-888-441-2494
Fax: (317) 232-5923
Email: uccinfo@iurc.in.gov
Dated February 14, 2013.
(S - 2/14/13 - 6037885)

Form 65-REV

PUBLISHER'S AFFIDAVIT

State of Indiana SS:
MARION County

Personally appeared before me, a notary public in and for said county and state, the undersigned Kerry Dodson who, being duly sworn, says that SHE is clerk of the INDIANAPOLIS NEWSPAPERS a DAILY STAR newspaper of general circulation printed and published in the English language in the city of INDIANAPOLIS in state and county aforesaid, and that the printed matter attached hereto is a true copy, which was duly published in said paper for 1 time(s), between the dates of: 02/14/2013 and 02/14/2013

Kerry Dodson Clerk
Title

Subscribed and sworn to before me on 02/14/2013
Louise M. Powell Notary Public

My commission expires: _____

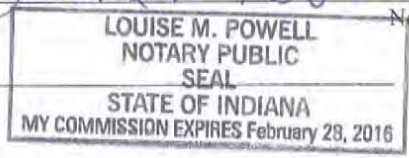

LEGAL NOTICE

Notice is hereby given that on or about February 20, 2013, Indianapolis Power & Light Company expects to submit a Power Purchase Agreements for Qualifying Renewable Energy Power Production between Grocers Supply, Inc., SEC MC Solar LLC and IPL dated February, 2013.

In addition, notice is hereby given that on or about February 20, 2013, Indianapolis Power & Light Company expects to submit a Power Purchase Agreement for Qualifying Renewable Energy Power Production between DEEM, LLC SEC MC Solar One, LLC and IPL dated February, 2013.

In addition, notice is hereby given that on or about February 20, 2013, Indianapolis Power & Light Company expects to submit a Power Purchase Agreement for Qualifying Renewable Energy Power Production between Indy Southside Sports Academy, Inc., Solscient Energy, LLC and IPL dated February, 2013.

In addition, notice is hereby given that on or about February 20, 2013, Indianapolis Power & Light Company expects to submit a Power Purchase Agreement for Qualifying Renewable Energy Power Production between Goodwill Industries of Central Indiana, Inc., 8345 Georgetown Road Solar I, LLC and IPL dated February, 2013.

In addition, notice is hereby given that on or about February 20, 2013, Indianapolis Power & Light Company expects to submit a Power Purchase Agreement for Qualifying Renewable Energy Power Production between the Trustees of Indiana University and IPL dated December 11, 2012.

In addition, notice is hereby given that on or about February 20, 2013, Indianapolis Power & Light Company expects to submit a Power Purchase Agreement for Qualifying Renewable Energy Power Production between 5855 LP and IPL dated February, 2013.

The Commission approved IPL's Rate REP (Renewable Energy Production) in its Order dated February 10, 2010 in Cause No. 43623 (Phase 1), and approved further modifications to Rate REP in its Order dated March 7, 2012 in Cause 44018, which authorized the long-term contracting of Qualifying Renewable Energy Power Production for up to fifteen (15) years subject to Commission approval of each contract. IPL anticipates approval of the filings on or before March 6, 2013.

This notice is provided to the public pursuant to 170 IAC 1-6-6. The contact information, to which an objection should be made, is as follows:

Secretary
Indiana Utility Regulatory Commission
101 W. Washington Street, Suite 1500 East
Indianapolis, Indiana 46204
Telephone:(317) 232-2700
Fax: (317) 232-6758
Email: info@urc.in.gov

Office of Utility Consumer Counselor
115 W. Washington Street, Suite 1500 South
Indianapolis, Indiana 46204
Telephone:(317) 232-2484
Toll Free: 1-888-441-2494
Fax: (317) 232-5923
Email: uccinfo@oucc.in.gov

Dated February 14, 2013.

Received On: February 20, 2013
IURC 30-DAY Filing No.: 3125
Indiana Utility Regulatory Commission

Indianapolis Power & Light Company
One Monument Circle
Indianapolis, Indiana

I.U.R.C. No. E-16

1st Revised No. 124
Superseding
Original No. 124

RATE REP
RENEWABLE ENERGY PRODUCTION

AVAILABILITY:

Voluntary offer available to (1) any Customer of Indianapolis Power & Light Company (the "Company") (2) or any Bidder in the Company's reverse auction (the "Reverse Auction") that operates within the Company's service territory a Qualifying Renewable Energy Power Production Facility subject to the Company's rules and regulations and, any terms, conditions and restrictions imposed by any valid and applicable law or regulation and negotiates a written contract with the Company that is approved by the Commission before March 30, 2013. This tariff sets forth the cost levels eligible for retail ratemaking purposes and is submitted pursuant to the requirements of the Commission and shall cease to be effective if such regulations are set aside, withdrawn or for any reason cease to be applicable to the Company. An Existing Qualifying Renewable Energy Power Production Facility is eligible to offer electricity to the Company under this Rate REP except as otherwise expressly forbidden by law.

DEFINITIONS:

- (a) Qualifying Renewable Energy Power Production Facility (the "Facility") means an arrangement of equipment for the production of electricity with capacity no less than 50 kW (20 kW for solar) and no greater than 10 MW. The expected annual output from any project shall not exceed the annual consumption of the Host Facility, except in the case of Facilities that utilize Biomass or are providing the power in response to the Reverse Auction. The Facility shall be a QF or otherwise authorized by Federal law to make wholesale power sales. Except in the case of a Facility operated by a Bidder, the Facility shall be located at a Host Facility owned by a Customer and shall be located wholly within the boundaries of the Host Facility. A Host Facility shall be a building, production equipment or collection of same in the same area such as a campus located at one site and is not the aggregation of more than one site each less than 50 kW (20 kW for solar). The Host Facility or portion of the Host Facility on which the Facility is located must be wholly within the boundaries of the Company's service territory. The Facility of a Bidder must also be wholly within the boundaries of the Company's service territory. A Facility must produce electric power through the use of 100% renewable resources or fuel. Such resources or fuels include:
- a. Solar photovoltaic cells and panels
 - b. Wind
 - c. Dedicated crops grown for energy production
 - d. Organic waste biomass
 - e. Biomass will be consistent with the State's definition in IC 8-1-37-4(a)(5).
- (b) Purchase means the purchase of electric energy or capacity or both from the Facility by the Company and is also inclusive of all Environmental Attributes.
- (c) Sale means the sale of electric energy or capacity or both by the Facility to the Company and is also inclusive of all environmental attributes.
- (d) Environmental Attributes means Renewable Energy Credits ("REC"), carbon credits, greenhouse gas offsets or any other environmental credit, commodity or classification that may be associated with the production of renewable energy from the Facility.
- (e) Interconnection Costs means the reasonable costs of connection, switching, metering, transmission, distribution, safety provisions, and administrative costs incurred by the Company directly related to the installation and maintenance of the physical facilities necessary to permit interconnected operations with a Facility, to the extent such costs are in excess of the corresponding costs which the Company would have incurred if it had not engaged in interconnected operations, but instead generated an equivalent amount of electric energy itself or Purchased an equivalent amount of electric energy or capacity from other sources.

ISSUED PURSUANT TO

44018

Indianapolis Power & Light Company
One Monument Circle
Indianapolis, Indiana

I.U.R.C. No. E-16

1st Revised No. 124.1
Superseding
Original No. 124.1

RATE REP (Continued)

- Interconnection Costs do not include any costs included in the calculation of Avoided Costs.
- (f) System Emergency means a condition on the Company's system which is liable to result in imminent significant disruption of service to Customers or in substantial deviation from normal service standards or which is imminently liable to endanger life or property.
 - (g) Commission means the Indiana Utility Regulatory Commission.
 - (h) FERC means Federal Energy Regulatory Commission.
 - (i) Peak Period means the time between 6 a.m. and 10 p.m. (April through September) or between 7 a.m. and 11 p.m. (October through March) on all days except Saturdays and Sundays, which daily time period will be subject to change from time to time at the Company's option. This change would occur after no less than ten (10) days notice has been given to all Customers who would be affected, and to the Commission.
 - (j) Off Peak Period means the time not included in the Peak Period.
 - (k) QF means a Facility qualifying as a qualifying small power production facility pursuant to 16 U.S.C. § 796(17)(C).
 - (l) Bidder means a participant in the Reverse Auction whose proposed Sale of energy from a Facility to the Company is accepted by Company and results in the execution of an approved agreement for a Sale no later than January 30, 2013.

PURCHASE AND SALE:

Purchases and Sales shall also be subject to the following general terms and conditions:

- a. The Company shall not be obligated to Purchase or sell at a time of System Emergency.
- b. The Customer or Bidder shall sell the total production of the Facility to the Company.
- c. The Customer or Bidder shall receive service for their load at the appropriate retail rate from the Company. The applicable rate is not impacted by the Customer's participation in Rate REP.
- d. The Company will not offer contracts to any additional Customers if that additional contract would result in the projected energy purchased under Rate REP (inclusive of the Reverse Auction) in a given year exceeding 153,000 MWh/year (the "Cap"). The Company shall set aside 45,900 MWh/year of the Cap to be available for Bidders in the Reverse Auction, provided that nothing herein shall be construed as requiring the Company to secure 45,900 MWh/year through the Reverse Auction. Upon completion of the Reverse Auction, any remaining portion shall be offered to Customers.
- e. The Company may recognize the costs of the Purchase for retail ratemaking purposes.

INTERCONNECTION CONDITIONS AND COSTS:

- (a) The Company, subject to prior compliance by the Facility with all applicable Federal and State laws and regulations, shall make parallel interconnection with the Facility in such a way as to accomplish Purchases and Sales as described in Sections (b) through (f).
- (b) The Facility shall comply with the National Electrical Safety Code, as supplemented, the applicable requirements of 170 IAC 4-4.3, and the Company's rules and regulations for electric service.
- (c) Interconnection Costs from the Facility to the Company's distribution or transmission system, including those costs of (d) and (e) below, shall be borne by the Facility. If a Customer is contracting with third-parties to own and operate the Facility, both the third-party and the Customer will be responsible for and pay for the interconnection agreement. The Customer will be responsible in the event of a default by the third-party. There shall be no obligation on the Company to finance such interconnection.

ISSUED PURSUANT TO

44018

Effective March 7, 2012

Indianapolis Power & Light Company
 One Monument Circle
 Indianapolis, Indiana

I.U.R.C. No. E-16

1st Revised No. 124.2
 Superseding
 Original No. 124.2

RATE REP (Continued)

- (d) The Facility shall install, operate, and maintain in good order such relays, locks and seals, breakers, automatic synchronizer, and other control and protective apparatus as shall be designated by the Company for operation parallel to its system. The Facility shall bear full responsibility for the installation and safe operation of this equipment.
- (e) Breakers capable of isolating the Facility from the Company shall at all times be immediately accessible to the Company. The Company may isolate the Facility at its own discretion if the Company believes continued parallel operation with the Facility creates or contributes to a System Emergency. System Emergencies causing discontinuance of parallel operation are subject to verification by the Commission.
- (f) To properly record numbers of kilowatt-hours for, respectively, Purchase and Sale, the following configurations shall be the basis for metering.
 - (1) Where such measurement is appropriate for measurement of energy, the circuit shall include at minimum one monodirectional meter between, at one side, the Company system and, on the other side, the load and a bidirectional meter between, at one side, the Company system and on the other side, the Facility and any load associated with it
 - (2) Where such measurement is appropriate for measurement of energy, the circuit shall include a monodirectional meter between the on-site load and the Company and, in a series arrangement, two monodirectional meters between the Facility and the Company system:

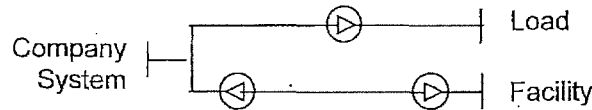

- (3) The meter measuring Purchases by the Company shall be of a design to record time periods, and shall be capable of electronically transmitting instantaneous readings.
- (4) Other metering arrangements shall be the subject of negotiations between the Company and the Customer or Bidder.

RATE REP PURCHASE RATES:

The rate the Company will pay each Customer for energy and capacity Purchased from their Facility will be established in advance by written contract with the Company. Unless otherwise agreed and approved by the Commission the RATE REP PURCHASE RATES eligible for retail ratemaking purposes shall not exceed:

(a)	Solar		
	a. Capacity		None
	b. Energy		
		(a)	For Facilities generating 20 kW to 100 kW: 24.0¢ per KWH
		(b)	For Facilities generating more than 100 kW: 20.0¢ per KWH
(b)	Wind		
	a. Capacity		None
	b. Energy		
		(a)	For Facilities generating 50 kW to 100 kW: 14.0¢ per KWH
		(b)	For Facilities generating 100 kW to 1 MW: 10.5¢ per KWH
		(c)	For Facilities generating more than 1 MW: 7.5¢ per KWH

ISSUED PURSUANT TO

44018

Indianapolis Power & Light Company
One Monument Circle
Indianapolis, Indiana

I.U.R.C. No. E-16

1st Revised No. 124.3
Superseding
Original No. 124.3

RATE REP (Continued)

- (c) Biomass
 - a. Capacity \$6.18 per KW per month
 - b. Energy 8.5¢ per KWH

The length of any contract shall not exceed fifteen (15) years. The Company and the Customer or Bidder may negotiate terms and a rate for energy or capacity in recognition of the following factors:

- (1) The extent to which scheduled outages of the Facility can be usefully coordinated with scheduled outages of the Company's generation facilities;
- (2) The relationship of the availability of energy from the Facility to the ability of the Company to avoid costs, particularly as is evidenced by the Company's ability to dispatch the Facility;
- (3) The usefulness of the Facility during System Emergencies, including the ability of the Facility to separate its load from its generation;
- (4) The impact of improvements in costs or performance of technologies, tax credits, grants and other financial incentives that when combined with the rate would produce excessive profits for the Facility.
- (5) Rates and adjustments prescribed in the contract shall remain in effect notwithstanding changes made to the RATE REP PURCHASE RATES from time to time.
- (6) The extent to which the Company is authorized to recognize the cost of such Purchase for retail ratemaking purposes pursuant to Ind. Code § 8-1-8.8-1 *et. seq.*

Prior to finalizing the contract, the Company shall seek approval via the IURC's 30-day administrative filing process to recognize the costs of such Purchase for retail ratemaking purposes pursuant to Ind. Code § 8-1-8.8-1 et. seq.

RATES FOR SALE BY COMPANY:

Back-up Power may be provided under Standard Contract Rider No. 10. Maintenance Power shall be provided under Standard Contract Rider No. 11. Supplementary Power shall be provided under Standard Contract Rider No. 12. A Customer or Bidder may not simultaneously qualify for Rate REP, Rate CGS Cogeneration and Small Power Production, Standard Contract Rider No. 9, Net Metering, and Standard Contract Rider No. 8 for off-peak service.

STANDARD CONTRACT RIDERS APPLICABLE:

No. 1	see Page 150
No. 10	see Page 162
No. 11	see Page 163
No. 12	see Page 164

ISSUED PURSUANT TO

44078

INDIANA UTILITY REGULATORY COMMISSION

Effective March 7, 2012