

**Note To Reviewer**  
 Cross sections are provided only for areas of reconstruction and storm sewer improvements.

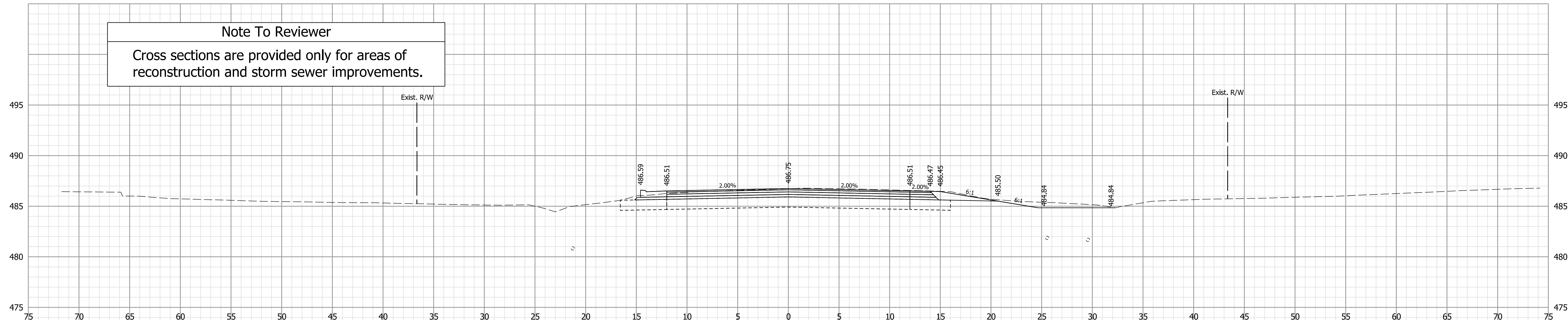

**157+00.00**

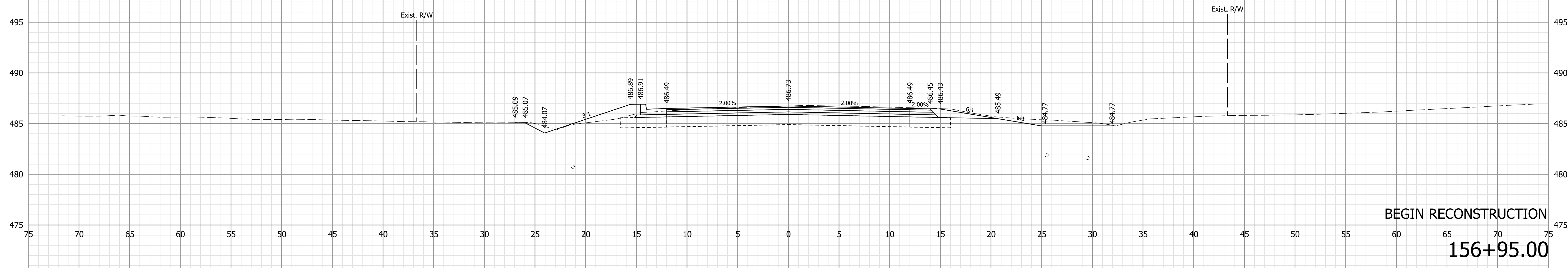

**BEGIN RECONSTRUCTION**  
**156+95.00**

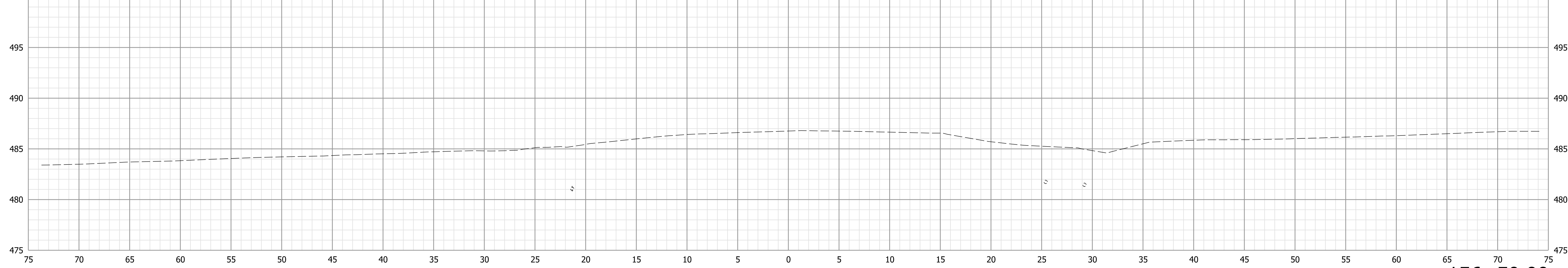

**156+50.00**

Plot: 6/9/2021 7:56:03 PM

**Note:**  
 1. All utilities information shall be considered QL-D unless otherwise indicated and is for informational purposes only. The Contractor is responsible for locating and coordinating with utility companies in accordance with the plans and specifications.

**NOT FOR CONSTRUCTION**

RECOMMENDED FOR APPROVAL	DESIGN ENGINEER	6/9/2021	DATE
DESIGNED: WCM	6/9/2021	DRAWN: WCM	6/9/2021
CHECKED: LNB	6/9/2021	CHECKED: LNB	6/9/2021

**INDIANA DEPARTMENT OF TRANSPORTATION**

**CROSS SECTIONS LINE "B"**

HORIZONTAL SCALE	BRIDGE FILE
1" = 5'	N/A
VERTICAL SCALE	DESIGNATION
1" = 5'	1900334
SURVEY BOOK	SHEETS
Electronic	1 of 89
CONTRACT	PROJECT
R-42228	1900334

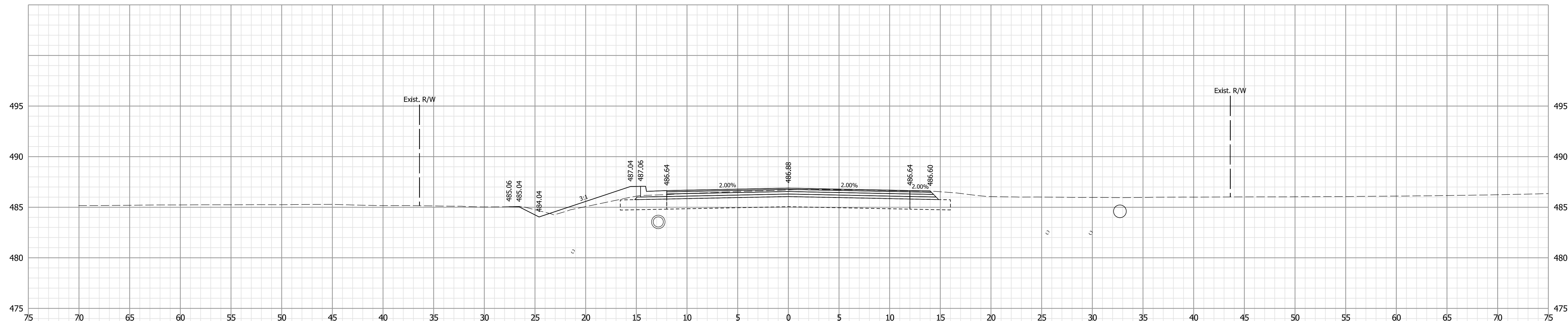

157+45.00

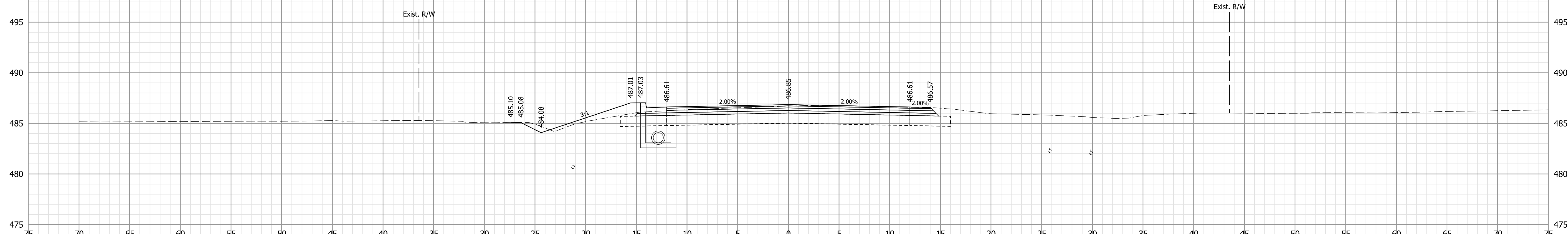

157+35.00

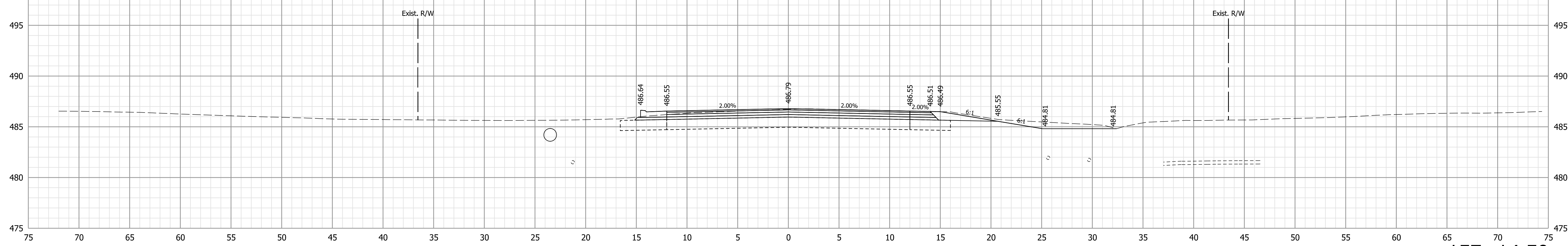

157+14.50

Note:  
 1. All utilities information shall be considered QL-D unless otherwise indicated and is for informational purposes only. The Contractor is responsible for locating and coordinating with utility companies in accordance with the plans and specifications.

**NOT FOR CONSTRUCTION**

RECOMMENDED FOR APPROVAL	DESIGN ENGINEER	6/9/2021	DATE
DESIGNED: WCM	6/9/2021	DRAWN: WCM	6/9/2021
CHECKED: LNB	6/9/2021	CHECKED: LNB	6/9/2021

INDIANA  
 DEPARTMENT OF TRANSPORTATION

CROSS SECTIONS  
 LINE "B"

HORIZONTAL SCALE	BRIDGE FILE
1" = 5'	N/A
VERTICAL SCALE	DESIGNATION
1" = 5'	1900334
SURVEY BOOK	SHEETS
Electronic	2 of 89
CONTRACT	PROJECT
R-42228	1900334

Plot: 6/9/2021 7:56:07 PM

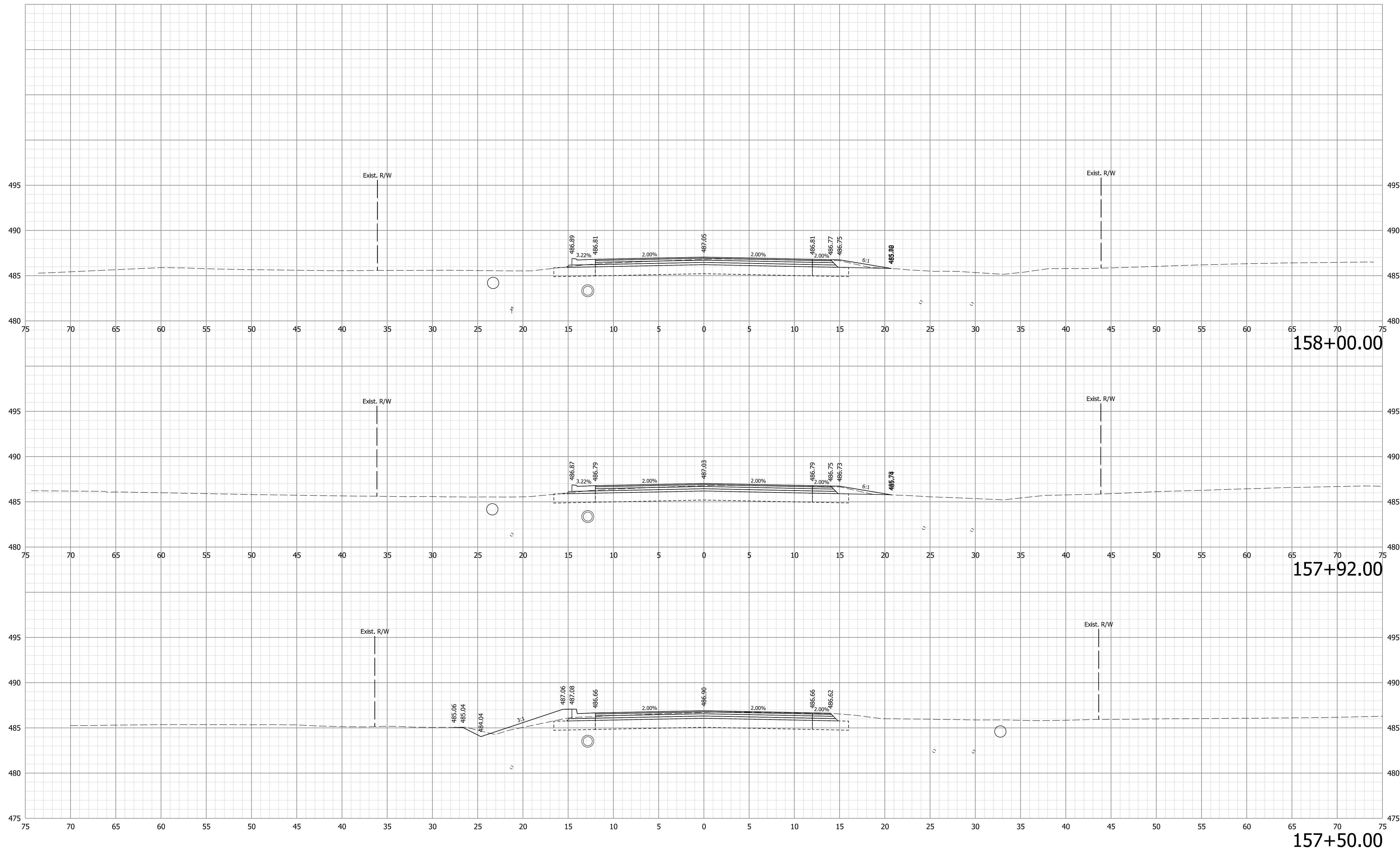

Note:  
 1. All utilities information shall be considered QL-D unless otherwise indicated and is for informational purposes only. The Contractor is responsible for locating and coordinating with utility companies in accordance with the plans and specifications.

**NOT FOR CONSTRUCTION**

RECOMMENDED FOR APPROVAL	DESIGN ENGINEER	6/9/2021	DATE
DESIGNED: WCM	6/9/2021	DRAWN: WCM	6/9/2021
CHECKED: LNB	6/9/2021	CHECKED: LNB	6/9/2021

**INDIANA  
DEPARTMENT OF TRANSPORTATION**

**CROSS SECTIONS  
LINE "B"**

HORIZONTAL SCALE	BRIDGE FILE
1" = 5'	N/A
VERTICAL SCALE	DESIGNATION
1" = 5'	1900334
SURVEY BOOK	SHEETS
Electronic	3 of 89
CONTRACT	PROJECT
R-42228	1900334

Plot: 6/9/2021 7:56:10 PM

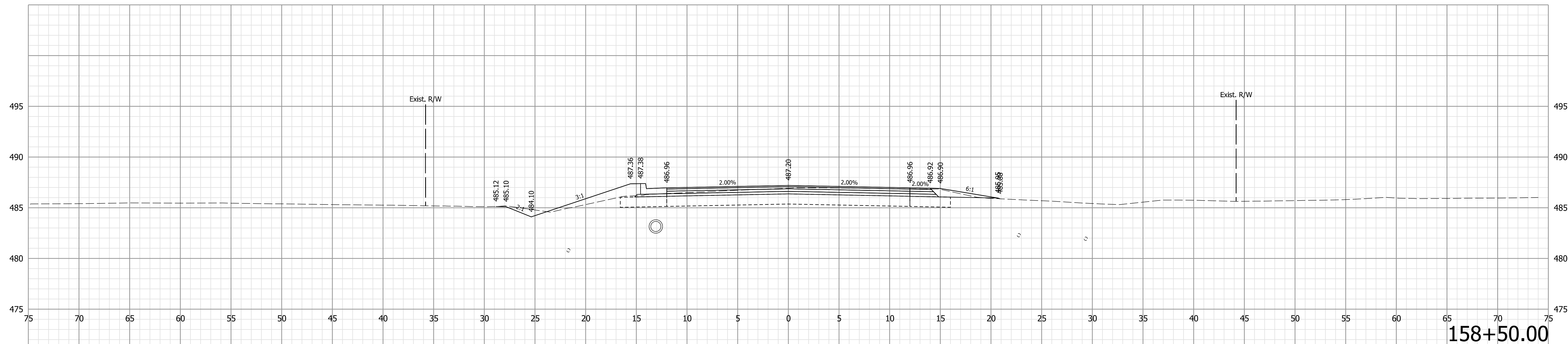

158+50.00

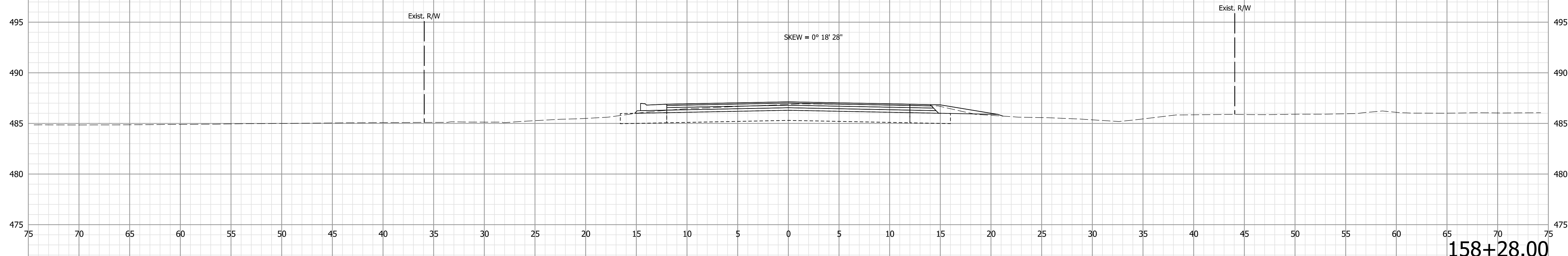

158+28.00

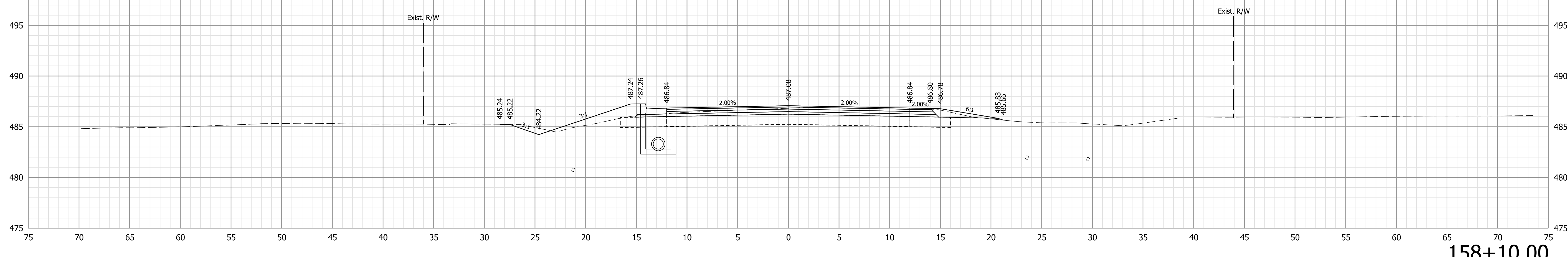

158+10.00

Note:  
1. All utilities information shall be considered QL-D unless otherwise indicated and is for informational purposes only. The Contractor is responsible for locating and coordinating with utility companies in accordance with the plans and specifications.

NOT FOR CONSTRUCTION

RECOMMENDED FOR APPROVAL	DESIGN ENGINEER	6/9/2021	DATE
DESIGNED: WCM	6/9/2021	DRAWN: WCM	6/9/2021
CHECKED: LNB	6/9/2021	CHECKED: LNB	6/9/2021

INDIANA  
DEPARTMENT OF TRANSPORTATION

CROSS SECTIONS  
LINE "B"

HORIZONTAL SCALE	BRIDGE FILE
1" = 5'	N/A
VERTICAL SCALE	DESIGNATION
1" = 5'	1900334
SURVEY BOOK	SHEETS
Electronic	4 of 89
CONTRACT	PROJECT
R-42228	1900334

Plot: 6/9/2021 7:56:12 PM

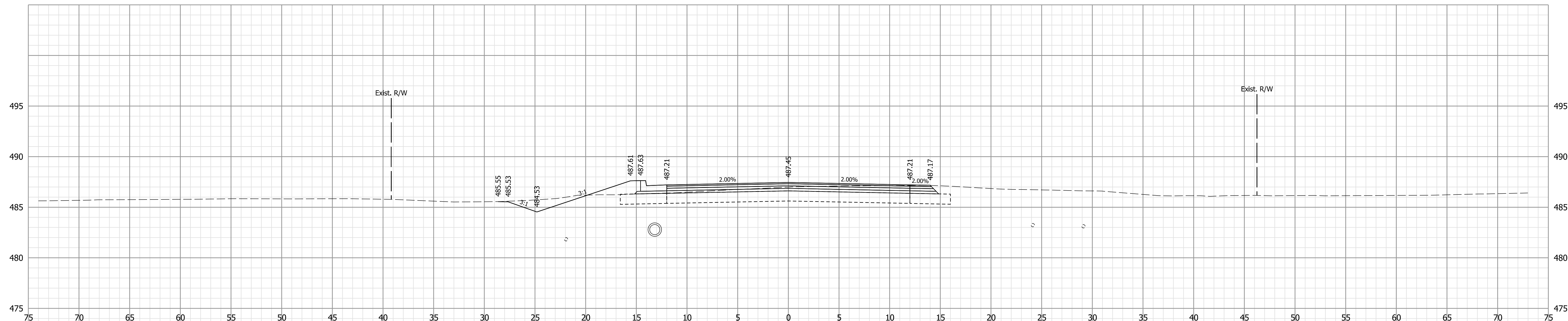

159+50.00

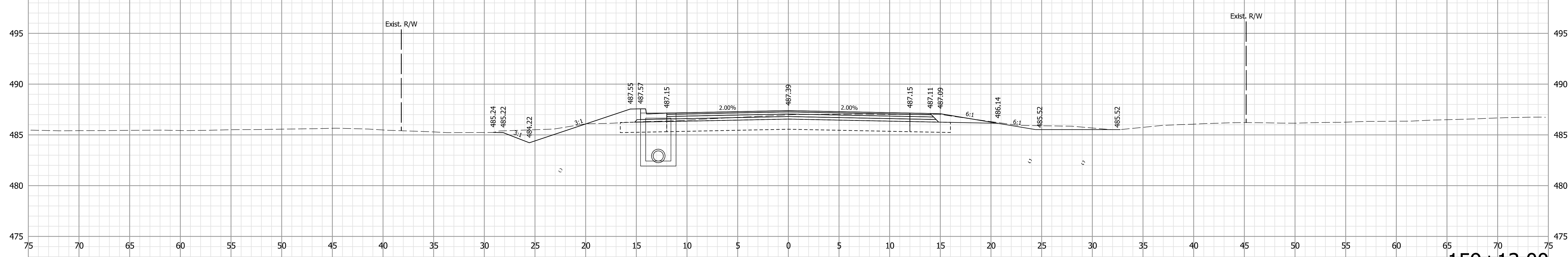

159+13.00

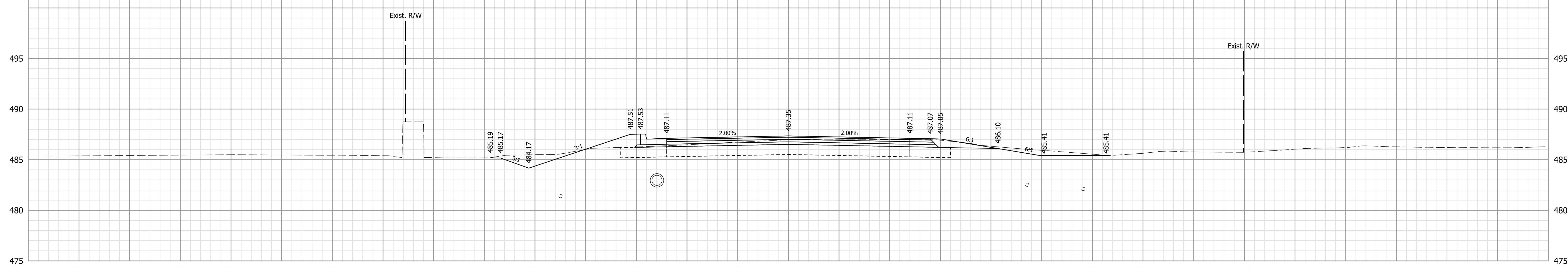

159+00.00

Note:  
1. All utilities information shall be considered QL-D unless otherwise indicated and is for informational purposes only. The Contractor is responsible for locating and coordinating with utility companies in accordance with the plans and specifications.

**NOT FOR CONSTRUCTION**

RECOMMENDED FOR APPROVAL	DESIGN ENGINEER	6/9/2021	DATE
DESIGNED: WCM	6/9/2021	DRAWN: WCM	6/9/2021
CHECKED: LNB	6/9/2021	CHECKED: LNB	6/9/2021

INDIANA  
DEPARTMENT OF TRANSPORTATION

CROSS SECTIONS  
LINE "B"

HORIZONTAL SCALE	BRIDGE FILE
1" = 5'	N/A
VERTICAL SCALE	DESIGNATION
1" = 5'	1900334
SURVEY BOOK	SHEETS
Electronic	5 of 89
CONTRACT	PROJECT
R-42228	1900334

Plot: 6/9/2021 7:56:15 PM

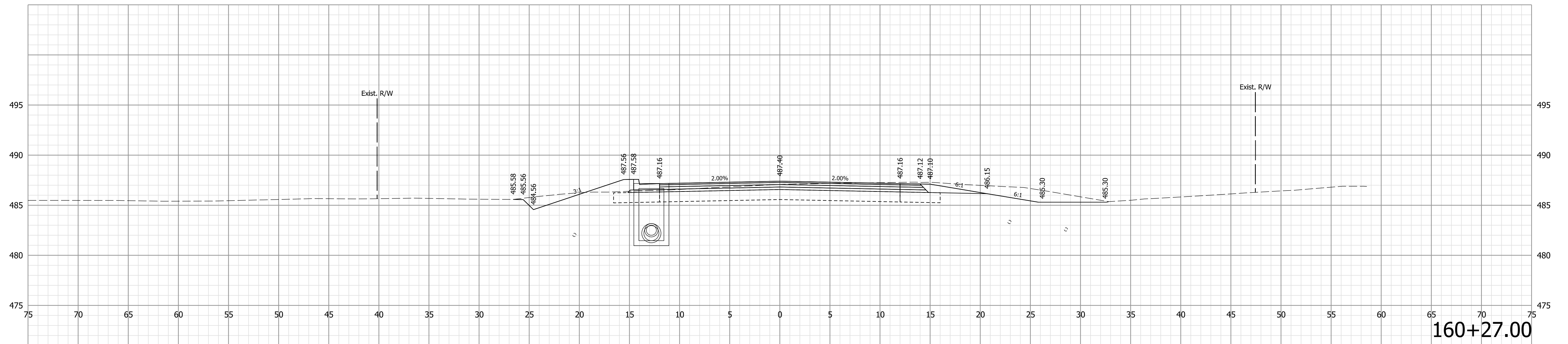

160+27.00

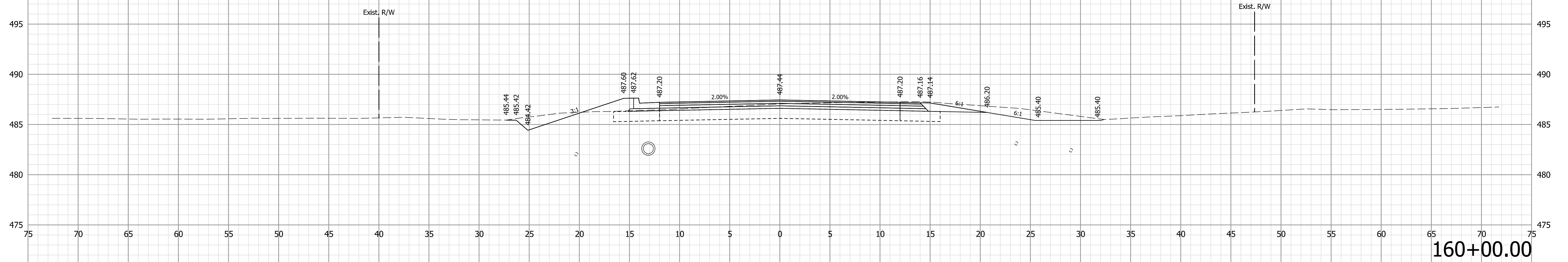

160+00.00

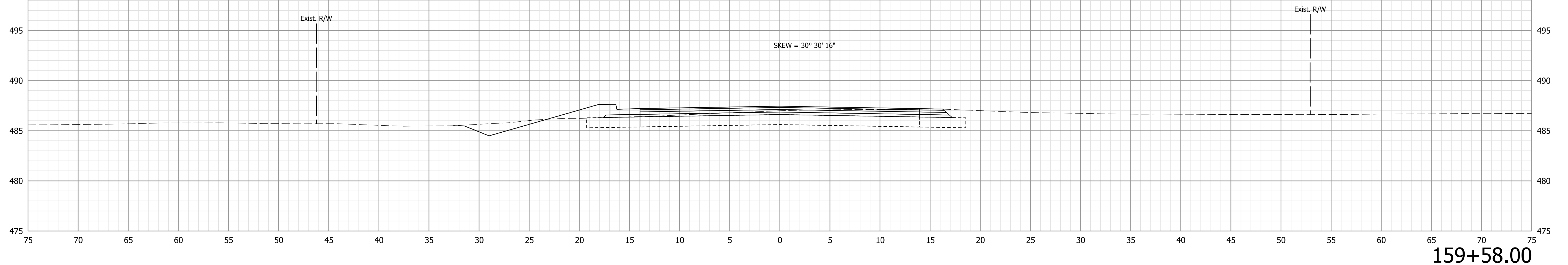

159+58.00

Note:  
 1. All utilities information shall be considered QL-D unless otherwise indicated and is for informational purposes only. The Contractor is responsible for locating and coordinating with utility companies in accordance with the plans and specifications.

**NOT FOR CONSTRUCTION**

RECOMMENDED FOR APPROVAL	DESIGN ENGINEER	6/9/2021	DATE
DESIGNED: WCM	6/9/2021	DRAWN: WCM	6/9/2021
CHECKED: LNB	6/9/2021	CHECKED: LNB	6/9/2021

INDIANA  
DEPARTMENT OF TRANSPORTATION

CROSS SECTIONS  
LINE "B"

HORIZONTAL SCALE	BRIDGE FILE
1" = 5'	N/A
VERTICAL SCALE	DESIGNATION
1" = 5'	1900334
SURVEY BOOK	SHEETS
Electronic	6 of 89
CONTRACT	PROJECT
R-42228	1900334

Plot: 6/9/2021 7:56:18 PM

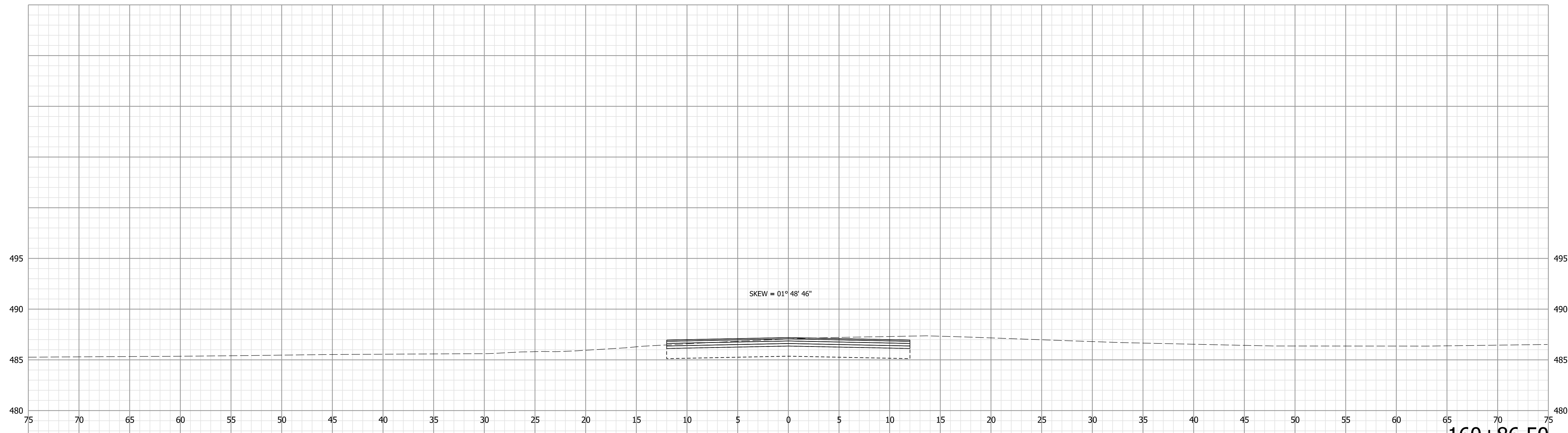

160+86.50

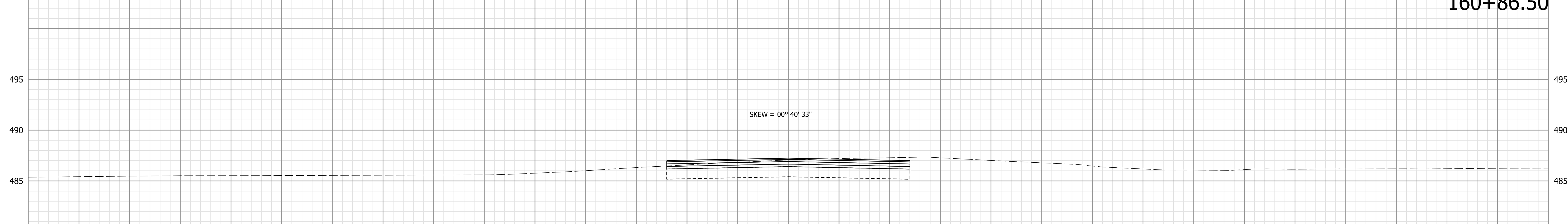

160+76.00

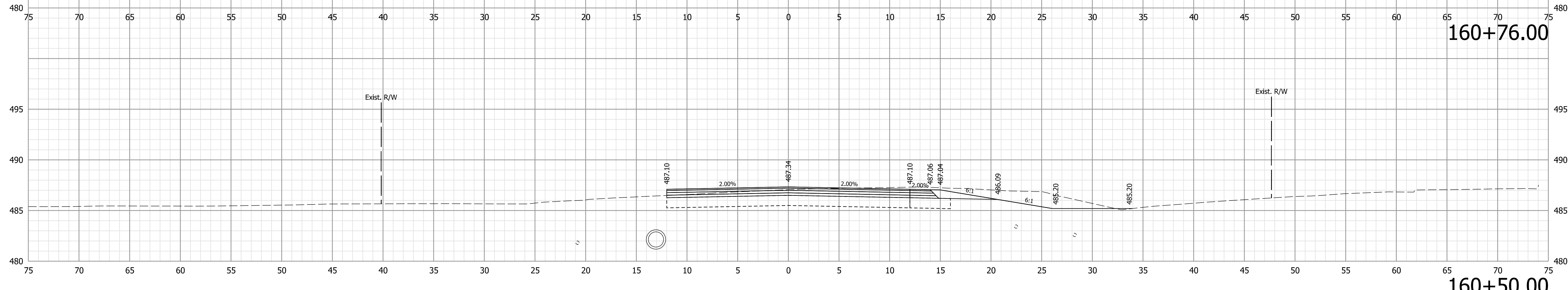

160+50.00

Note:  
 1. All utilities information shall be considered QL-D unless otherwise indicated and is for informational purposes only. The Contractor is responsible for locating and coordinating with utility companies in accordance with the plans and specifications.

**NOT FOR CONSTRUCTION**

RECOMMENDED FOR APPROVAL	DESIGN ENGINEER	6/9/2021	DATE
DESIGNED: WCM	6/9/2021	DRAWN: WCM	6/9/2021
CHECKED: LNB	6/9/2021	CHECKED: LNB	6/9/2021

INDIANA  
DEPARTMENT OF TRANSPORTATION

CROSS SECTIONS  
LINE "B"

HORIZONTAL SCALE	BRIDGE FILE
1" = 5'	N/A
VERTICAL SCALE	DESIGNATION
1" = 5'	1900334
SURVEY BOOK	SHEETS
Electronic	7 of 89
CONTRACT	PROJECT
R-42228	1900334

Plot: 6/9/2021 7:56:21 PM

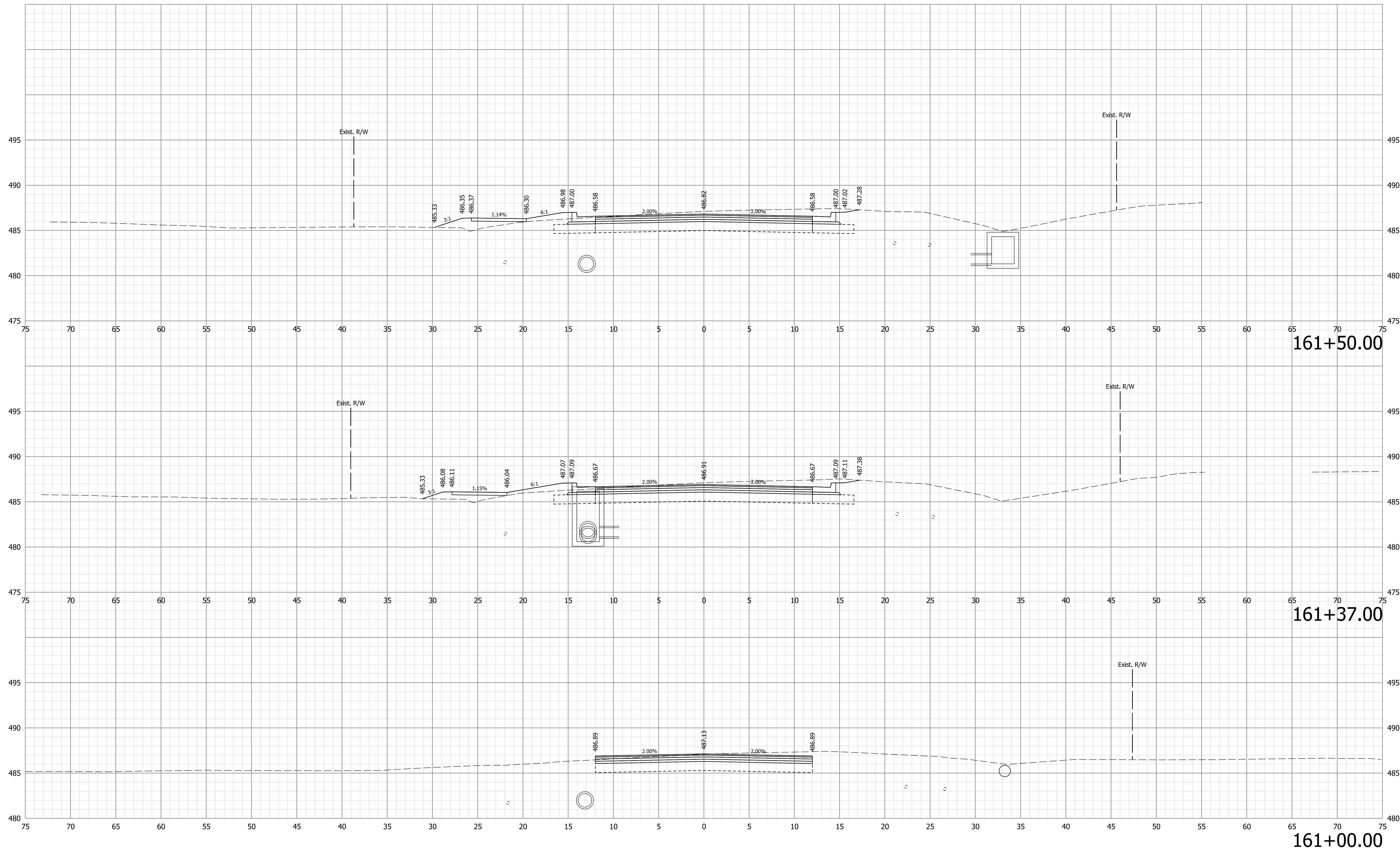

Note:  
 1. All utilities information shall be considered QL-D unless otherwise indicated and is for informational purposes only. The Contractor is responsible for locating and coordinating with utility companies in accordance with the plans and specifications.

**NOT FOR CONSTRUCTION**

RECOMMENDED FOR APPROVAL \_\_\_\_\_ 6/9/2021  
 DESIGN ENGINEER DATE  
 DESIGNED: WCM 6/9/2021 DRAWN: WCM 6/9/2021  
 CHECKED: LNB 6/9/2021 CHECKED: LNB 6/9/2021

INDIANA  
 DEPARTMENT OF TRANSPORTATION

CROSS SECTIONS  
 LINE "B"

HORIZONTAL SCALE 1" = 5'	BRIDGE FILE N/A
VERTICAL SCALE 1" = 5'	DESIGNATION 1900334
SURVEY BOOK Electronic	SHEETS 8 of 89
CONTRACT R-42228	PROJECT 1900334

Plot: 6/9/2021 7:56:24 PM



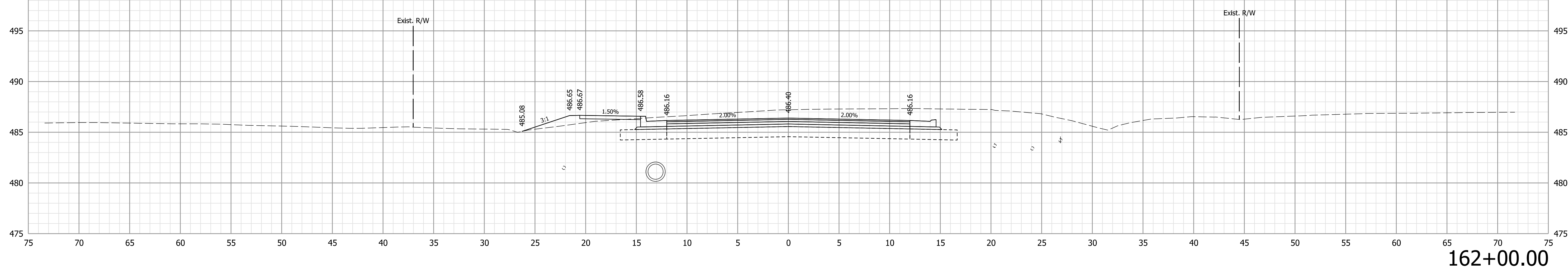
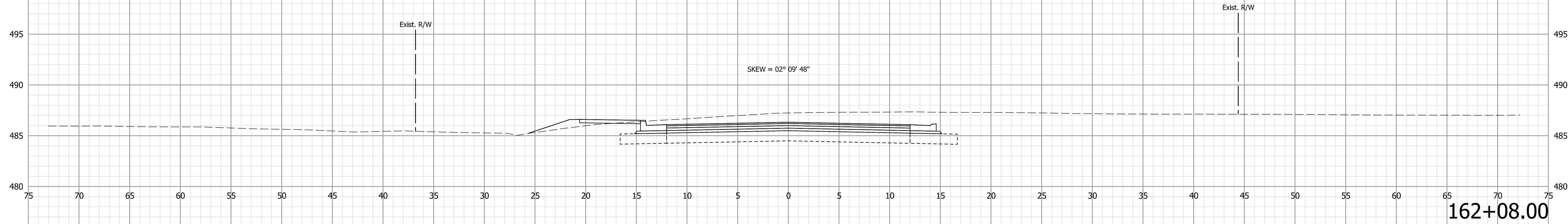
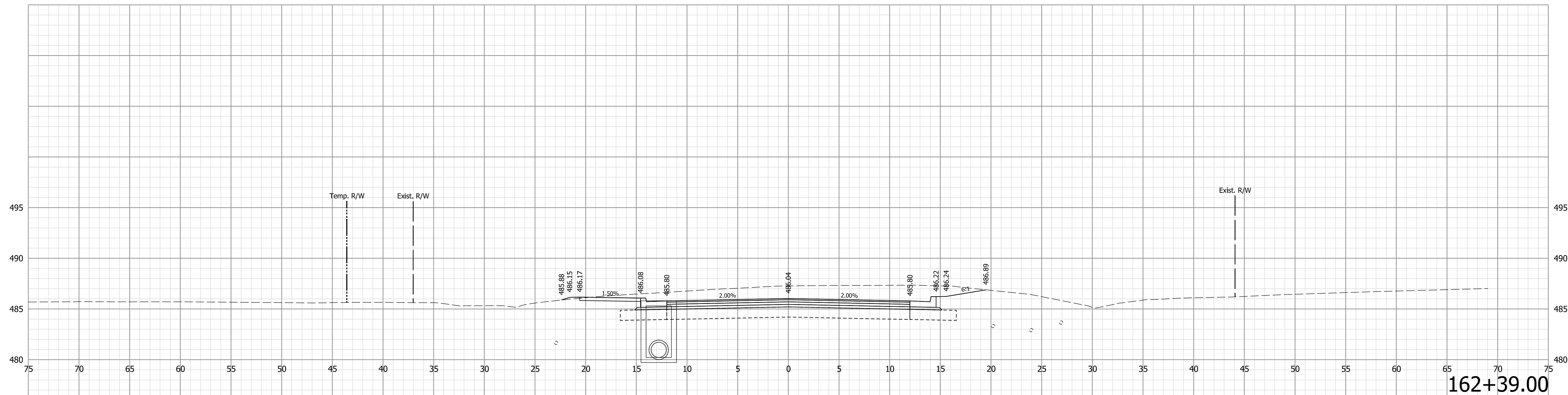

Note:  
 1. All utilities information shall be considered QL-D unless otherwise indicated and is for informational purposes only. The Contractor is responsible for locating and coordinating with utility companies in accordance with the plans and specifications.

**NOT FOR CONSTRUCTION**

RECOMMENDED FOR APPROVAL	DESIGN ENGINEER	6/9/2021	DATE
DESIGNED: WCM	6/9/2021	DRAWN: WCM	6/9/2021
CHECKED: LNB	6/9/2021	CHECKED: LNB	6/9/2021

INDIANA  
DEPARTMENT OF TRANSPORTATION

CROSS SECTIONS  
LINE "B"

HORIZONTAL SCALE	BRIDGE FILE
1" = 5'	N/A
VERTICAL SCALE	DESIGNATION
1" = 5'	1900334
SURVEY BOOK	SHEETS
Electronic	9 of 89
CONTRACT	PROJECT
R-42228	1900334

Plot: 6/9/2021 7:56:27 PM

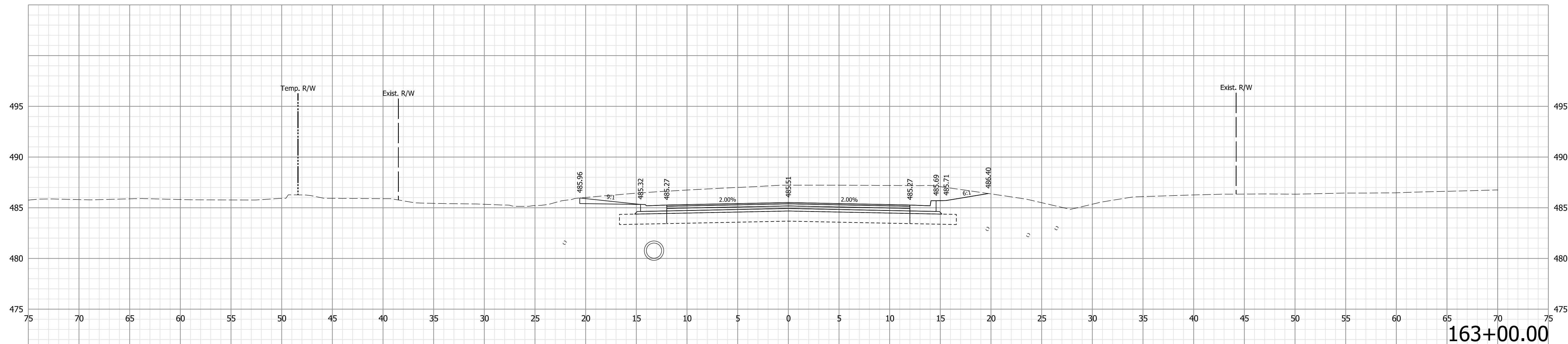

163+00.00

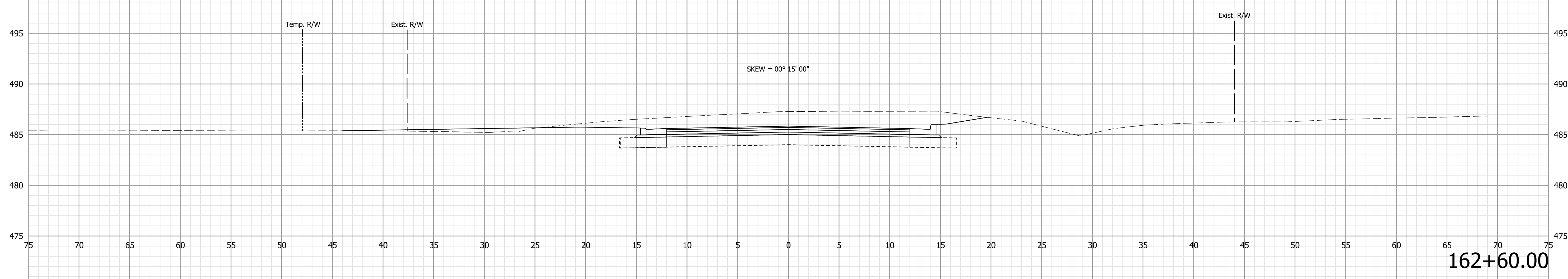

162+60.00

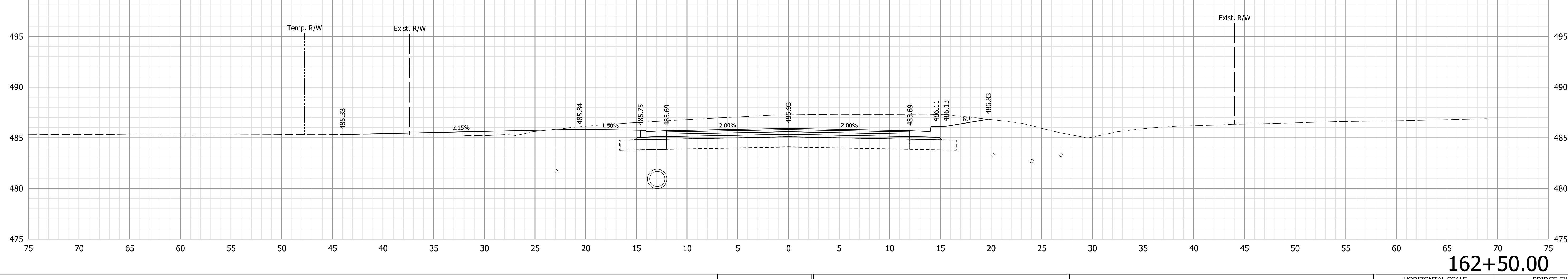

162+50.00

Note:  
1. All utilities information shall be considered QL-D unless otherwise indicated and is for informational purposes only. The Contractor is responsible for locating and coordinating with utility companies in accordance with the plans and specifications.

**NOT FOR CONSTRUCTION**

RECOMMENDED FOR APPROVAL	DESIGN ENGINEER	6/9/2021	DATE
DESIGNED: WCM	6/9/2021	DRAWN: WCM	6/9/2021
CHECKED: LNB	6/9/2021	CHECKED: LNB	6/9/2021

INDIANA  
DEPARTMENT OF TRANSPORTATION

CROSS SECTIONS  
LINE "B"

HORIZONTAL SCALE	BRIDGE FILE
1" = 5'	N/A
VERTICAL SCALE	DESIGNATION
1" = 5'	1900334
SURVEY BOOK	SHEETS
Electronic	10 of 89
CONTRACT	PROJECT
R-42228	1900334

Plot: 6/9/2021 7:56:29 PM

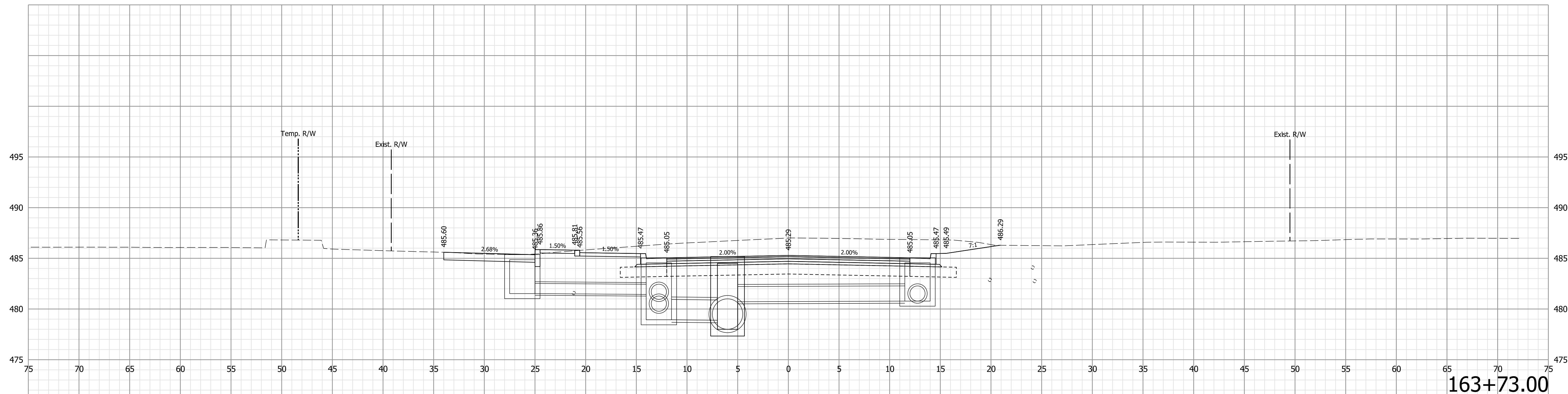

163+73.00

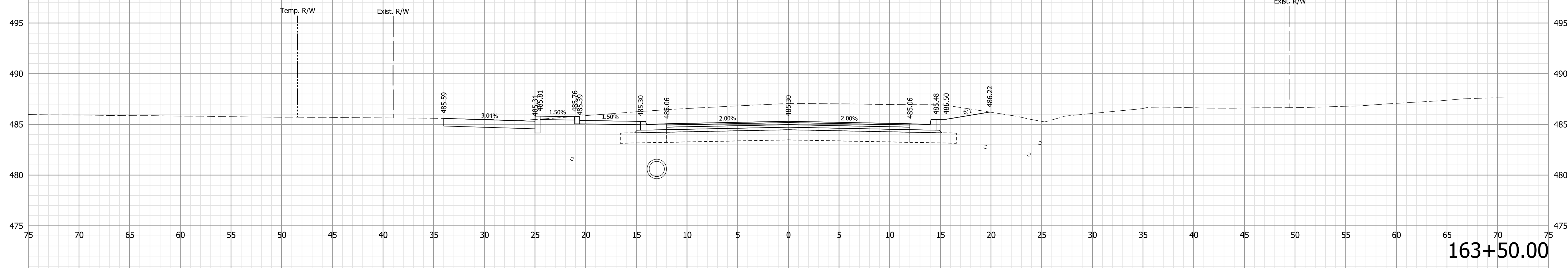

163+50.00

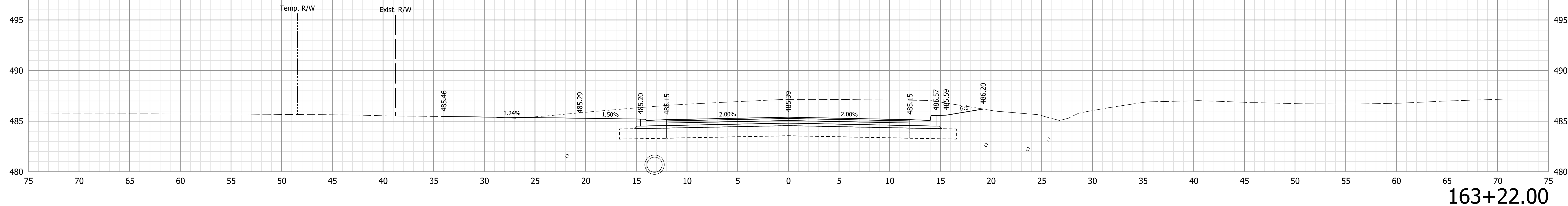

163+22.00

Note:  
 1. All utilities information shall be considered QL-D unless otherwise indicated and is for informational purposes only. The Contractor is responsible for locating and coordinating with utility companies in accordance with the plans and specifications.

**NOT FOR CONSTRUCTION**

RECOMMENDED FOR APPROVAL	DESIGN ENGINEER	6/9/2021	DATE
DESIGNED: WCM	6/9/2021	DRAWN: WCM	6/9/2021
CHECKED: LNB	6/9/2021	CHECKED: LNB	6/9/2021

INDIANA  
DEPARTMENT OF TRANSPORTATION

CROSS SECTIONS  
LINE "B"

HORIZONTAL SCALE	BRIDGE FILE
1" = 5'	N/A
VERTICAL SCALE	DESIGNATION
1" = 5'	1900334
SURVEY BOOK	SHEETS
Electronic	11 of 89
CONTRACT	PROJECT
R-42228	1900334

Plot: 6/9/2021 7:56:32 PM

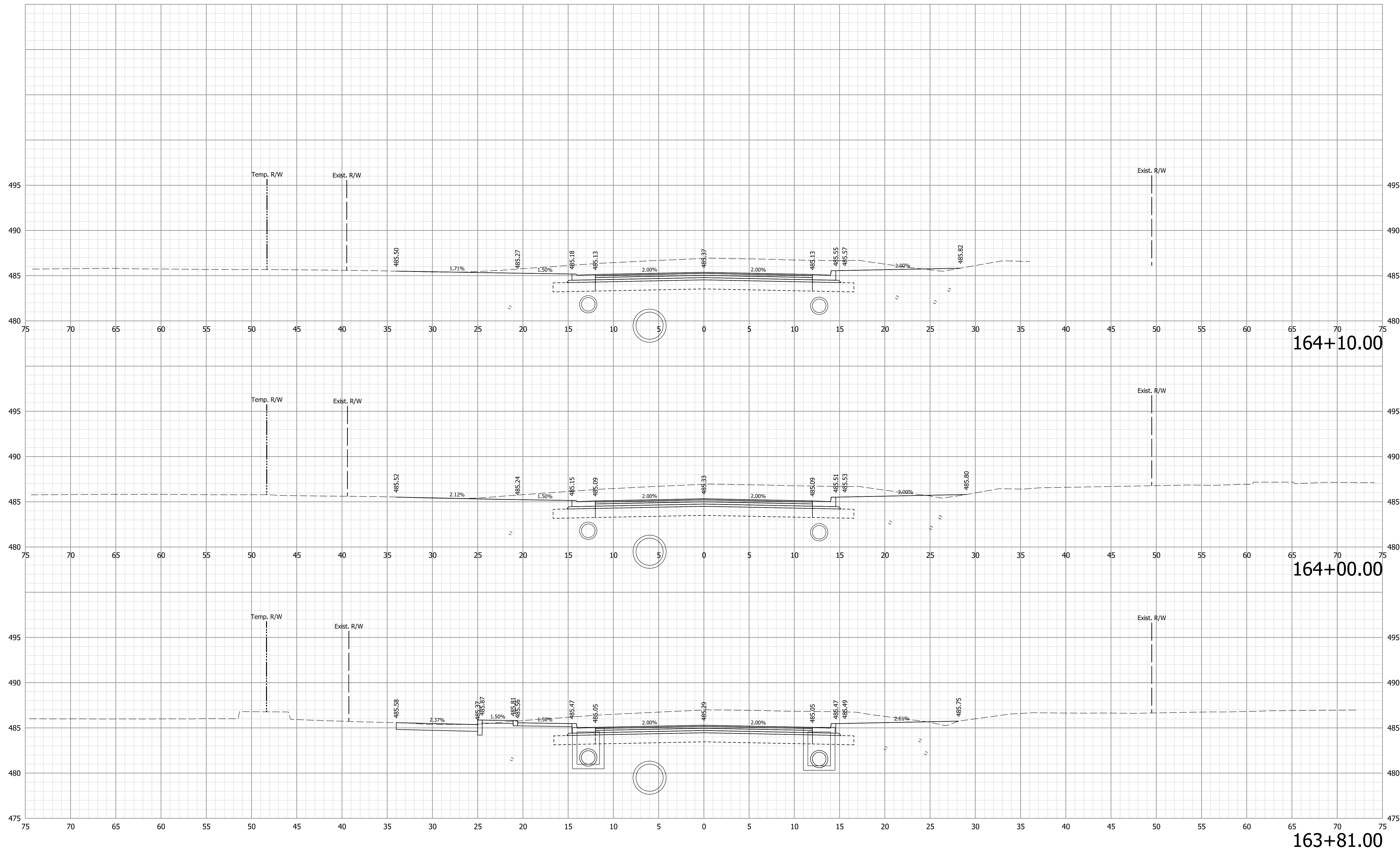

Note:  
 1. All utilities information shall be considered QL-D unless otherwise indicated and is for informational purposes only. The Contractor is responsible for locating and coordinating with utility companies in accordance with the plans and specifications.

**NOT FOR CONSTRUCTION**

RECOMMENDED FOR APPROVAL	DESIGN ENGINEER	6/9/2021	DATE
DESIGNED: WCM	6/9/2021	DRAWN: WCM	6/9/2021
CHECKED: LNB	6/9/2021	CHECKED: LNB	6/9/2021

INDIANA  
DEPARTMENT OF TRANSPORTATION

CROSS SECTIONS  
LINE "B"

HORIZONTAL SCALE	BRIDGE FILE
1" = 5'	N/A
VERTICAL SCALE	DESIGNATION
1" = 5'	1900334
SURVEY BOOK	SHEETS
Electronic	12 of 89
CONTRACT	PROJECT
R-42228	1900334

Plot: 6/9/2021 7:56:35 PM

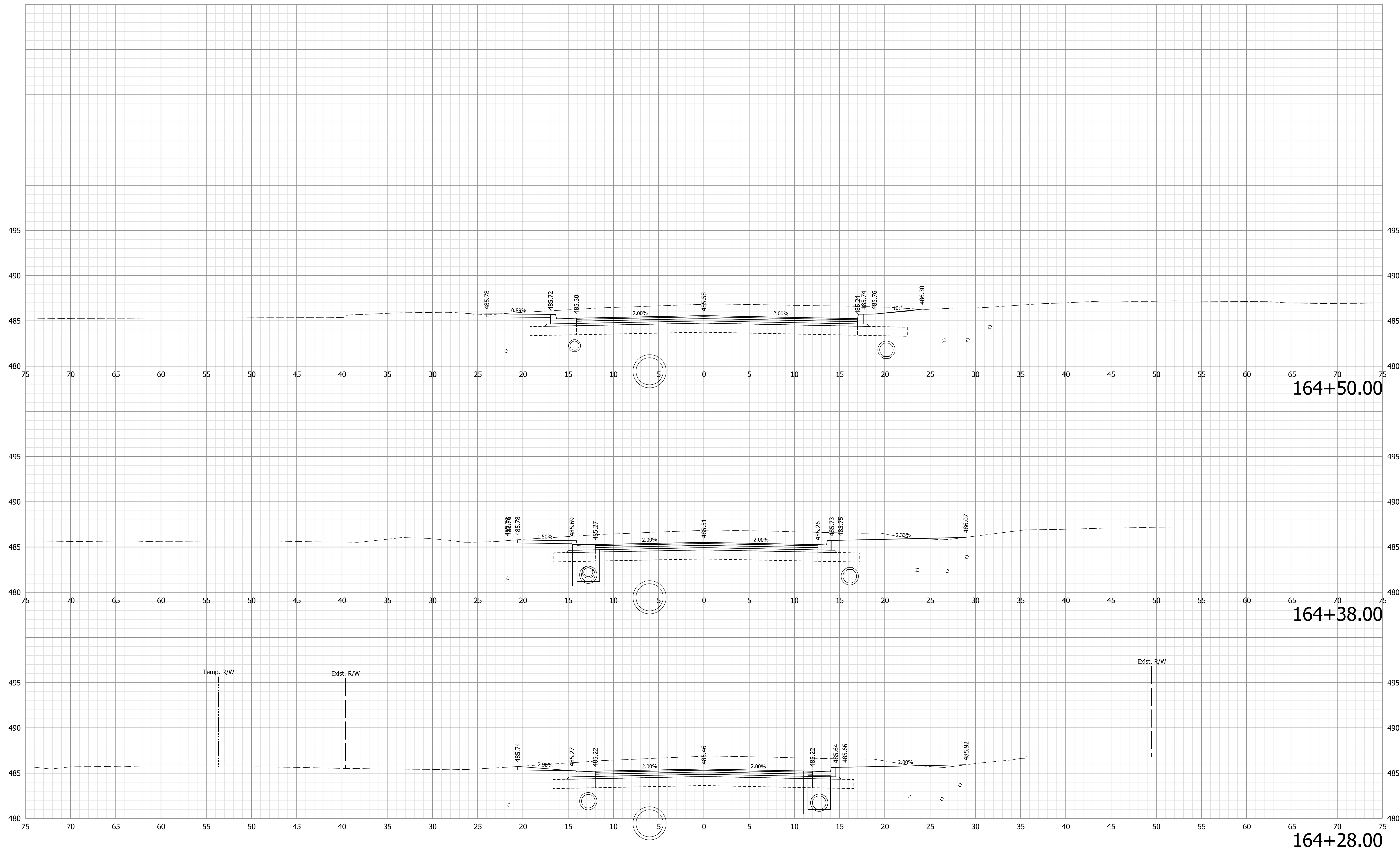

164+50.00

164+38.00

164+28.00

Note:  
 1. All utilities information shall be considered QL-D unless otherwise indicated and is for informational purposes only. The Contractor is responsible for locating and coordinating with utility companies in accordance with the plans and specifications.

**NOT FOR CONSTRUCTION**

RECOMMENDED FOR APPROVAL	DESIGN ENGINEER	6/9/2021	DATE
DESIGNED: WCM	6/9/2021	DRAWN: WCM	6/9/2021
CHECKED: LNB	6/9/2021	CHECKED: LNB	6/9/2021

INDIANA  
 DEPARTMENT OF TRANSPORTATION

CROSS SECTIONS  
 LINE "B"

HORIZONTAL SCALE	BRIDGE FILE
1" = 5'	N/A
VERTICAL SCALE	DESIGNATION
1" = 5'	1900334
SURVEY BOOK	SHEETS
Electronic	13 of 89
CONTRACT	PROJECT
R-42228	1900334

Plot: 6/9/2021 7:56:38 PM

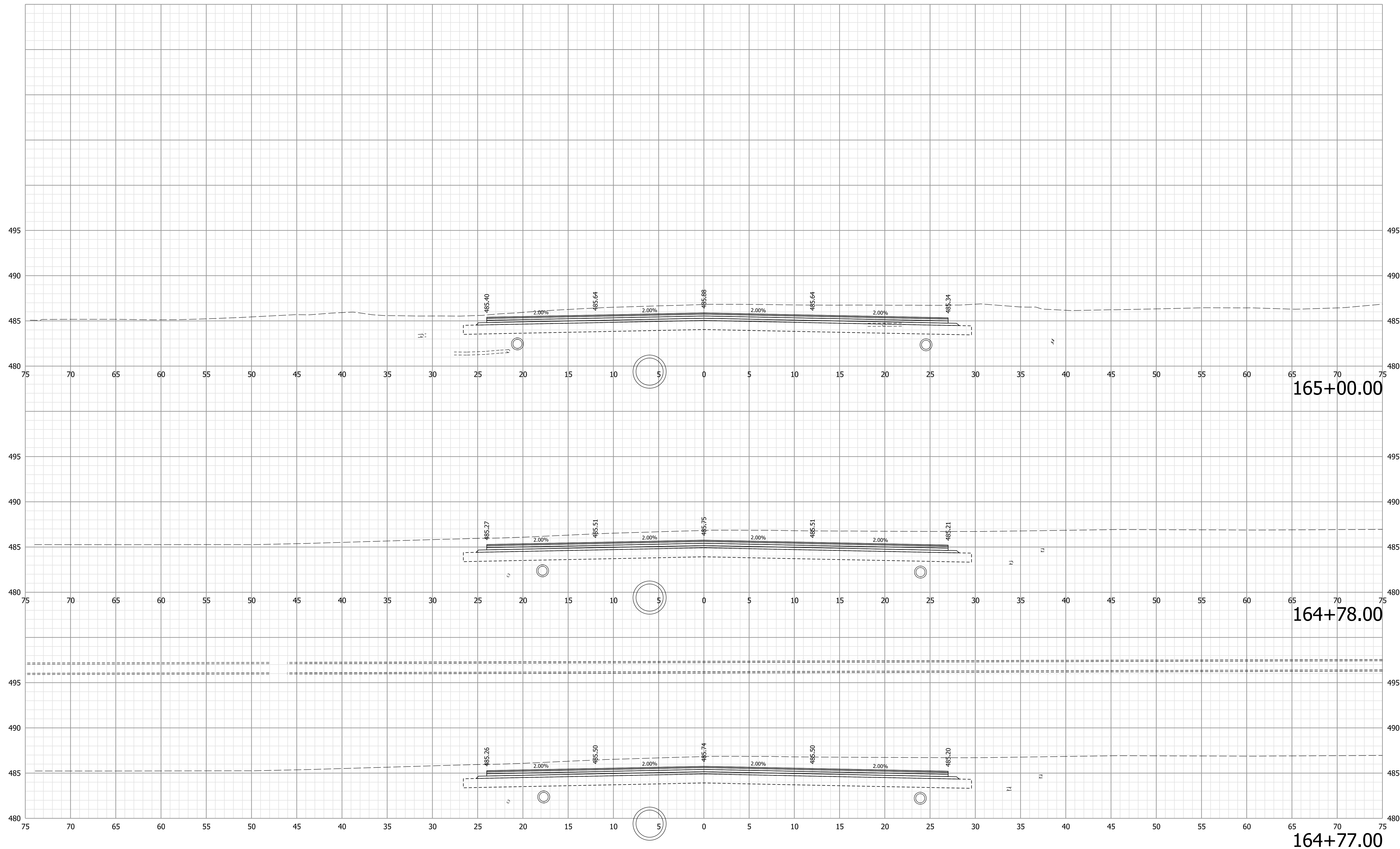

Note:  
 1. All utilities information shall be considered QL-D unless otherwise indicated and is for informational purposes only. The Contractor is responsible for locating and coordinating with utility companies in accordance with the plans and specifications.

**NOT FOR CONSTRUCTION**

RECOMMENDED FOR APPROVAL	DESIGN ENGINEER	6/9/2021	DATE
DESIGNED: WCM	6/9/2021	DRAWN: WCM	6/9/2021
CHECKED: LNB	6/9/2021	CHECKED: LNB	6/9/2021

**INDIANA  
DEPARTMENT OF TRANSPORTATION**

**CROSS SECTIONS  
LINE "B"**

HORIZONTAL SCALE	BRIDGE FILE
1" = 5'	N/A
VERTICAL SCALE	DESIGNATION
1" = 5'	1900334
SURVEY BOOK	SHEETS
Electronic	14 of 89
CONTRACT	PROJECT
R-42228	1900334

Plot: 6/9/2021 7:56:40 PM

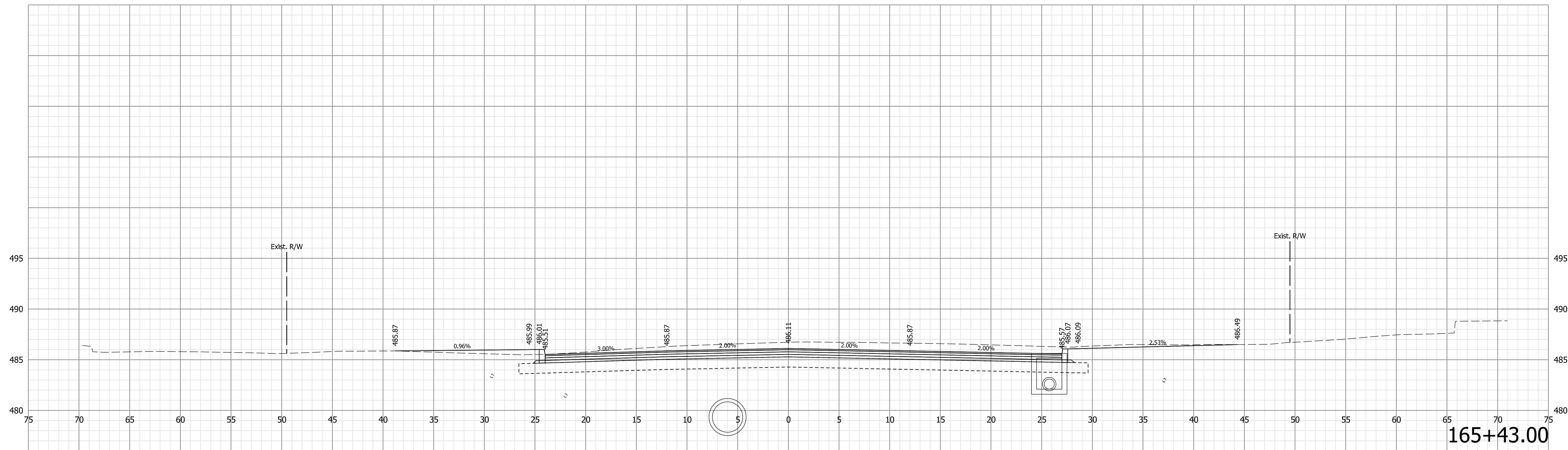

165+43.00

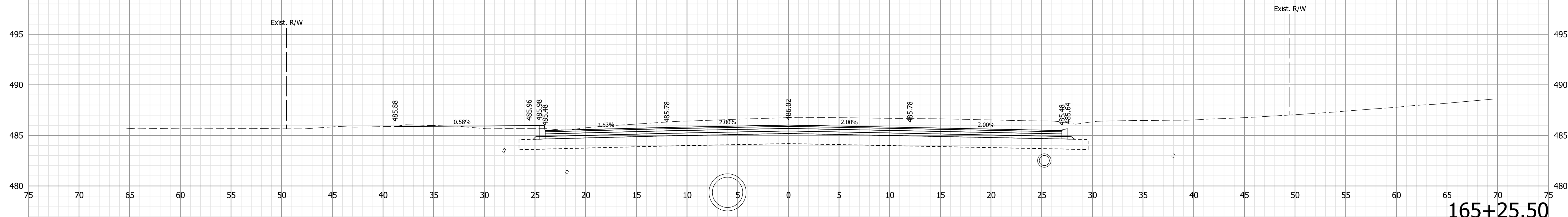

165+25.50

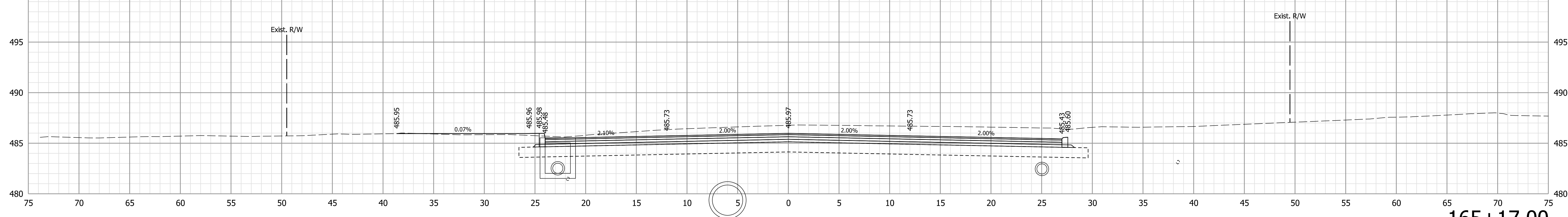

165+17.00

Note:  
1. All utilities information shall be considered QL-D unless otherwise indicated and is for informational purposes only. The Contractor is responsible for locating and coordinating with utility companies in accordance with the plans and specifications.

NOT FOR CONSTRUCTION

RECOMMENDED FOR APPROVAL	DESIGN ENGINEER	6/9/2021	DATE
DESIGNED: WCM	6/9/2021	DRAWN: WCM	6/9/2021
CHECKED: LNB	6/9/2021	CHECKED: LNB	6/9/2021

INDIANA  
DEPARTMENT OF TRANSPORTATION

CROSS SECTIONS  
LINE "B"

HORIZONTAL SCALE	BRIDGE FILE
1" = 5'	N/A
VERTICAL SCALE	DESIGNATION
1" = 5'	1900334
SURVEY BOOK	SHEETS
Electronic	15 of 89
CONTRACT	PROJECT
R-42228	1900334

Plot: 6/9/2021 7:56:43 PM

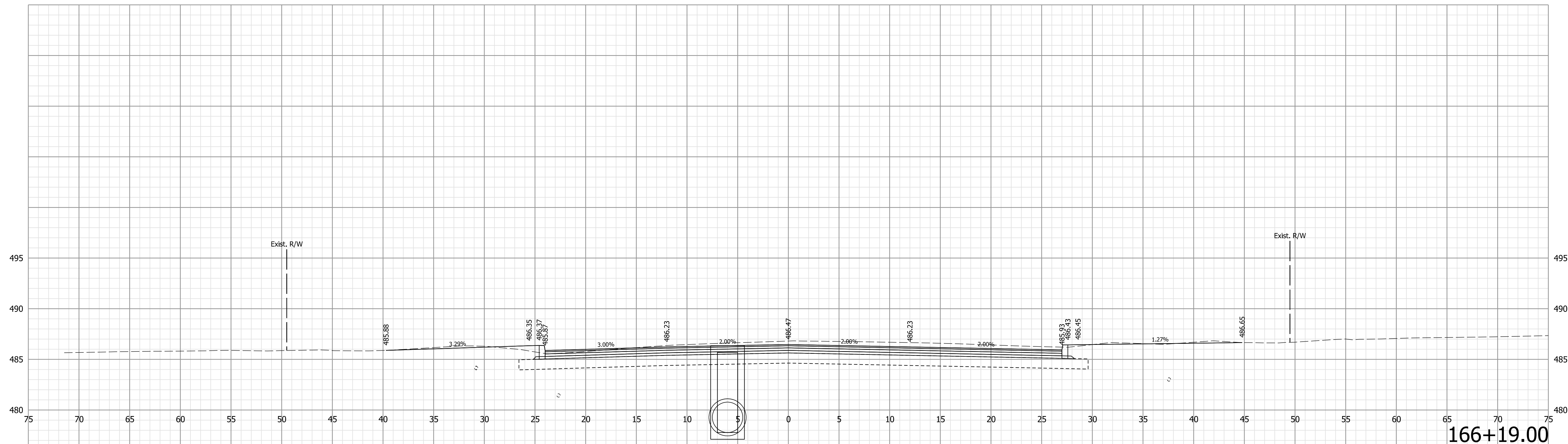

166+19.00

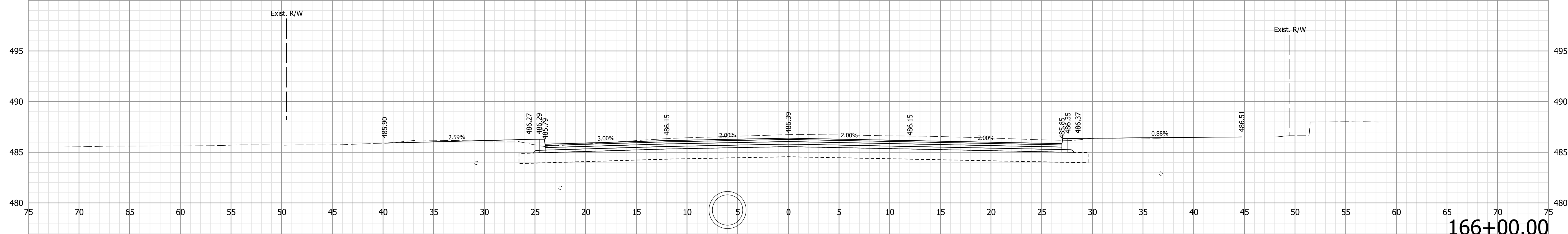

166+00.00

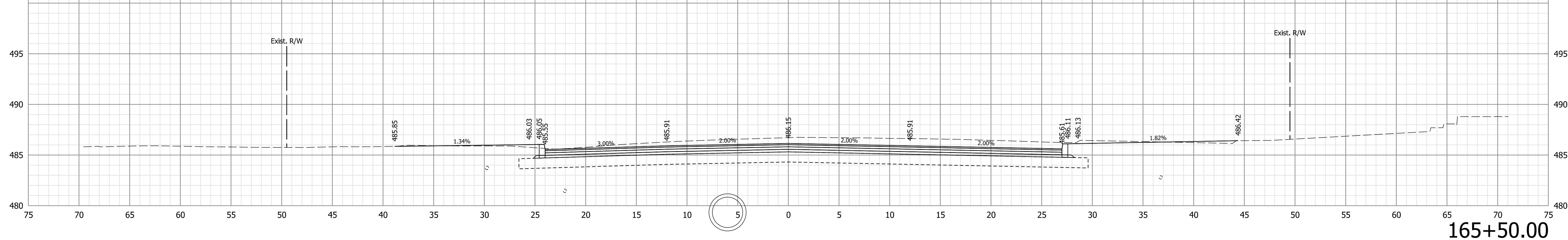

165+50.00

Note:  
1. All utilities information shall be considered QL-D unless otherwise indicated and is for informational purposes only. The Contractor is responsible for locating and coordinating with utility companies in accordance with the plans and specifications.

**NOT FOR CONSTRUCTION**

RECOMMENDED FOR APPROVAL	DESIGN ENGINEER	6/9/2021	DATE
DESIGNED: WCM	6/9/2021	DRAWN: WCM	6/9/2021
CHECKED: LNB	6/9/2021	CHECKED: LNB	6/9/2021

INDIANA  
DEPARTMENT OF TRANSPORTATION

CROSS SECTIONS  
LINE "B"

HORIZONTAL SCALE	BRIDGE FILE
1" = 5'	N/A
VERTICAL SCALE	DESIGNATION
1" = 5'	1900334
SURVEY BOOK	SHEETS
Electronic	16 of 89
CONTRACT	PROJECT
R-42228	1900334

Plot: 6/9/2021 7:56:46 PM



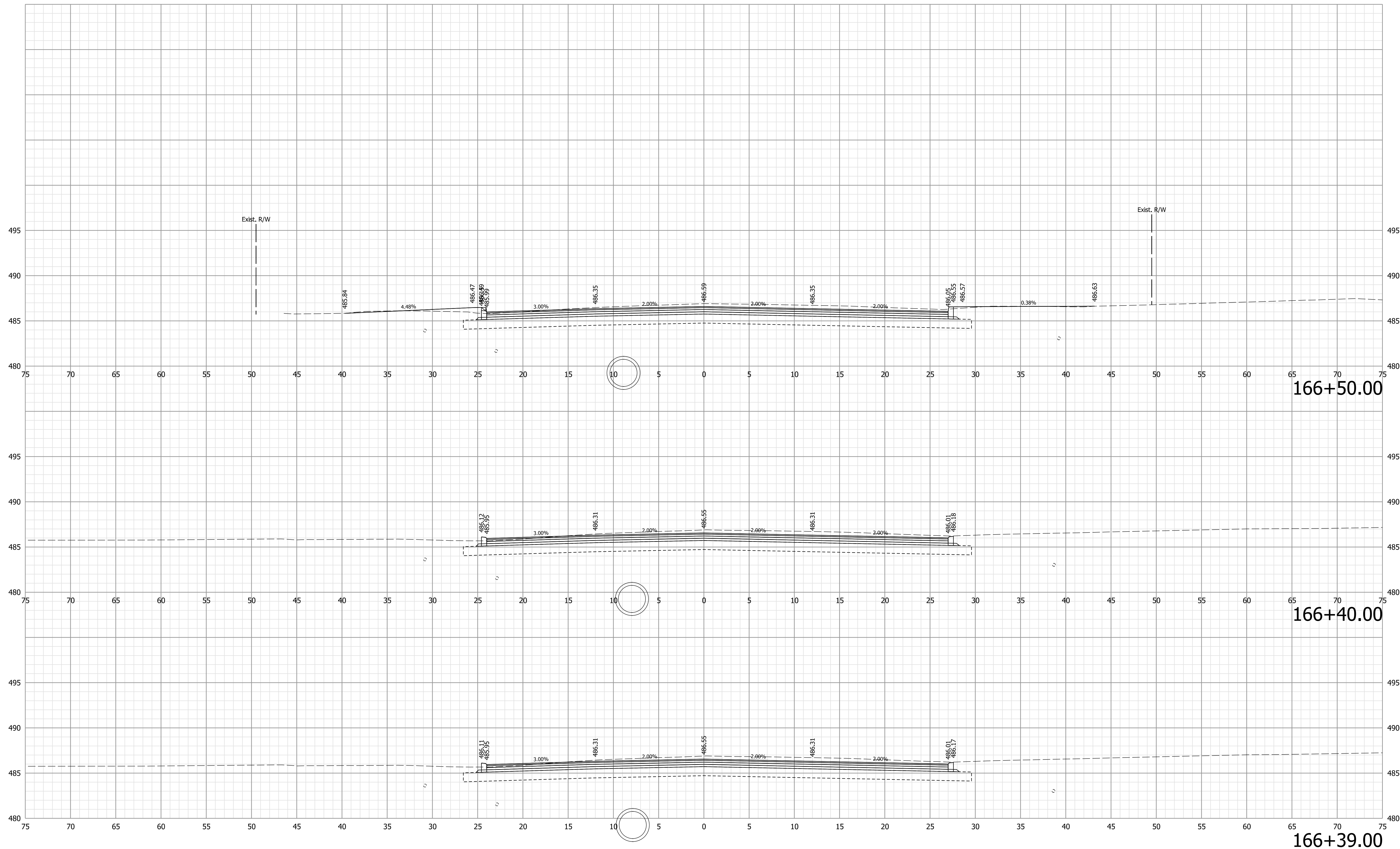

Note:  
 1. All utilities information shall be considered QL-D unless otherwise indicated and is for informational purposes only. The Contractor is responsible for locating and coordinating with utility companies in accordance with the plans and specifications.

**NOT FOR CONSTRUCTION**

RECOMMENDED FOR APPROVAL	DESIGN ENGINEER	6/9/2021	DATE
DESIGNED: WCM	6/9/2021	DRAWN: WCM	6/9/2021
CHECKED: LNB	6/9/2021	CHECKED: LNB	6/9/2021

INDIANA  
DEPARTMENT OF TRANSPORTATION

CROSS SECTIONS  
LINE "B"

HORIZONTAL SCALE	BRIDGE FILE
1" = 5'	N/A
VERTICAL SCALE	DESIGNATION
1" = 5'	1900334
SURVEY BOOK	SHEETS
Electronic	17 of 89
CONTRACT	PROJECT
R-42228	1900334

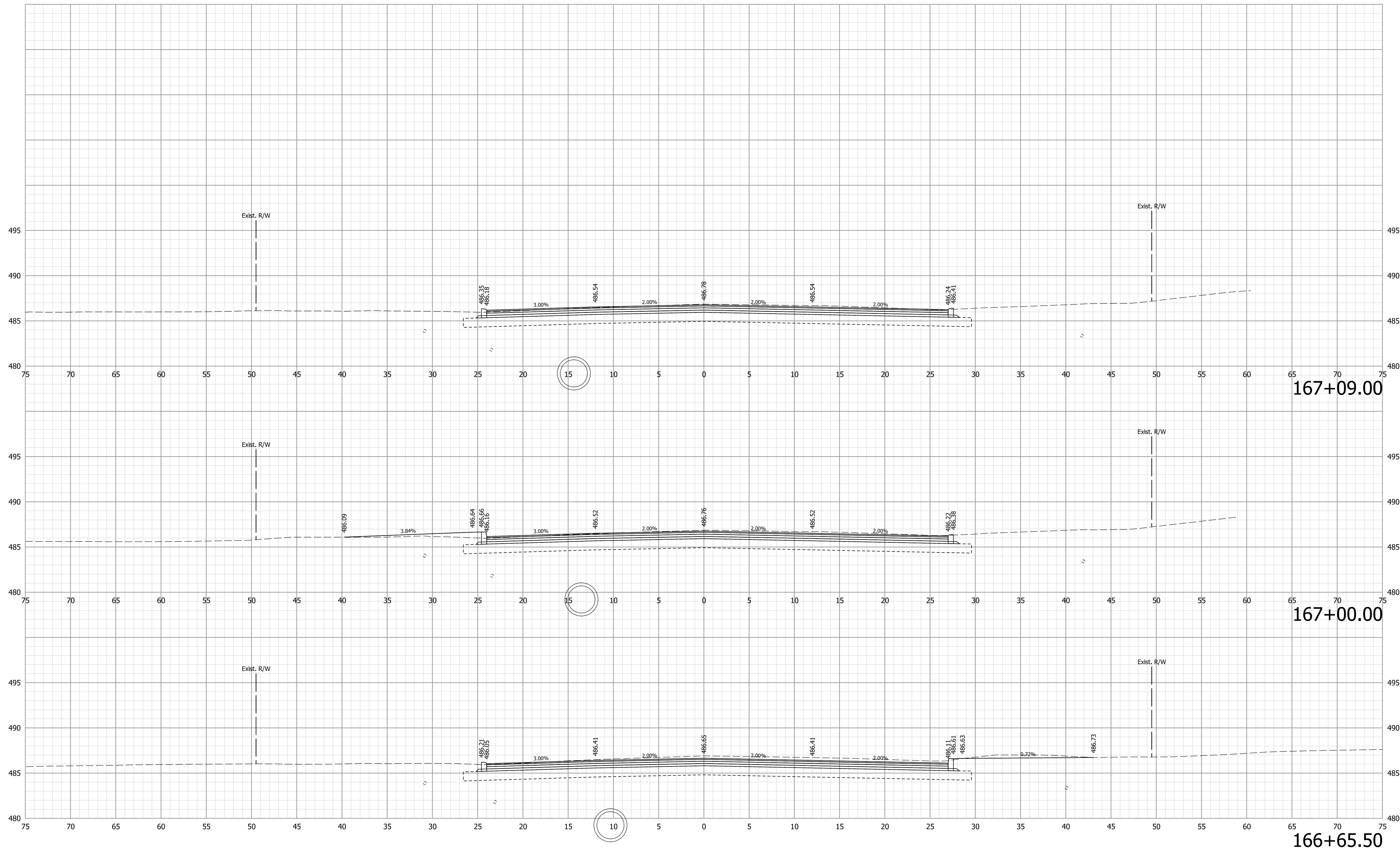

Note:  
 1. All utilities information shall be considered QL-D unless otherwise indicated and is for informational purposes only. The Contractor is responsible for locating and coordinating with utility companies in accordance with the plans and specifications.

**NOT FOR CONSTRUCTION**

RECOMMENDED FOR APPROVAL	DESIGN ENGINEER	6/9/2021	DATE
DESIGNED: WCM	6/9/2021	DRAWN: WCM	6/9/2021
CHECKED: LNB	6/9/2021	CHECKED: LNB	6/9/2021

INDIANA  
 DEPARTMENT OF TRANSPORTATION

CROSS SECTIONS  
 LINE "B"

HORIZONTAL SCALE	BRIDGE FILE
1" = 5'	N/A
VERTICAL SCALE	DESIGNATION
1" = 5'	1900334
SURVEY BOOK	SHEETS
Electronic	18 of 89
CONTRACT	PROJECT
R-42228	1900334

Plot: 6/9/2021 7:56:52 PM

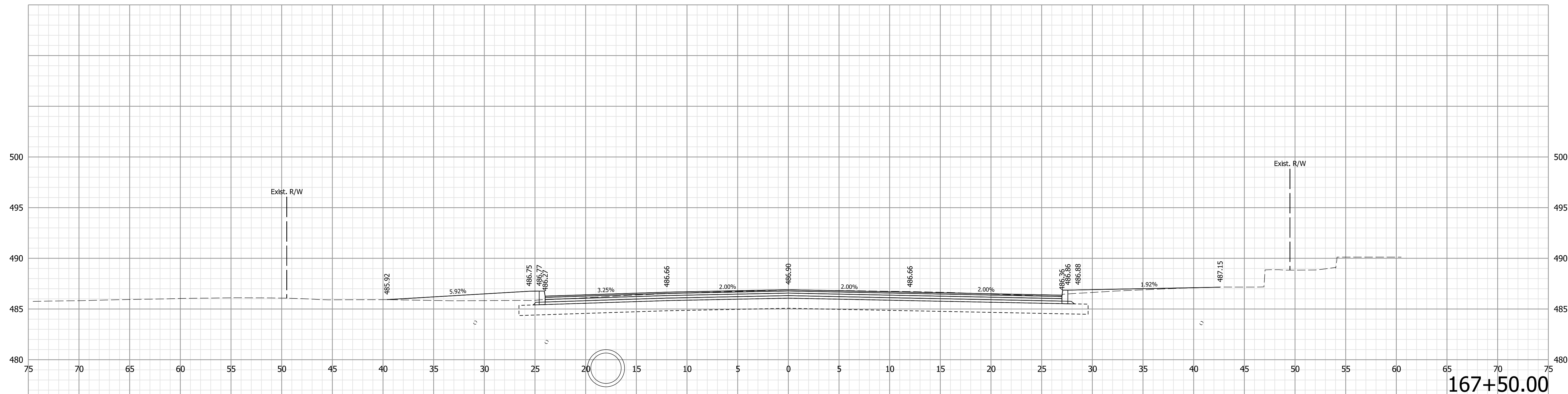

167+50.00

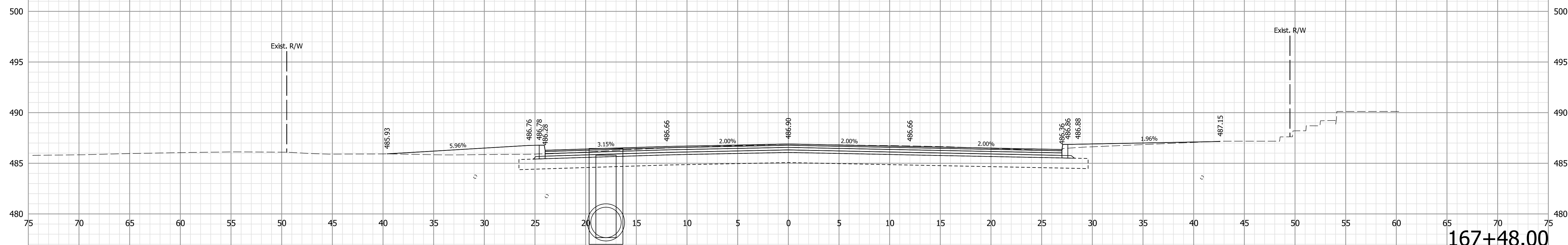

167+48.00

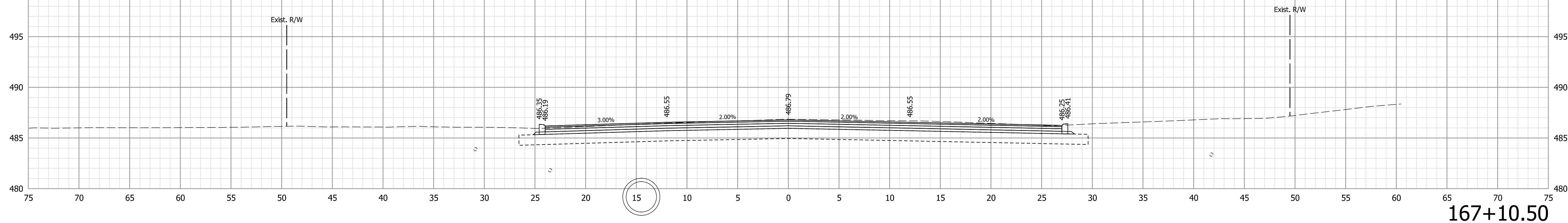

167+10.50

Note:  
 1. All utilities information shall be considered QL-D unless otherwise indicated and is for informational purposes only. The Contractor is responsible for locating and coordinating with utility companies in accordance with the plans and specifications.

NOT FOR CONSTRUCTION

RECOMMENDED FOR APPROVAL \_\_\_\_\_ 6/9/2021 DATE  
 DESIGN ENGINEER  
 DESIGNED: WCM 6/9/2021 DRAWN: WCM 6/9/2021  
 CHECKED: LNB 6/9/2021 CHECKED: LNB 6/9/2021

INDIANA DEPARTMENT OF TRANSPORTATION

CROSS SECTIONS LINE "B"

HORIZONTAL SCALE 1" = 5'	BRIDGE FILE N/A
VERTICAL SCALE 1" = 5'	DESIGNATION 1900334
SURVEY BOOK Electronic	SHEETS 19 of 89
CONTRACT R-42228	PROJECT 1900334

Plot: 6/9/2021 7:56:54 PM

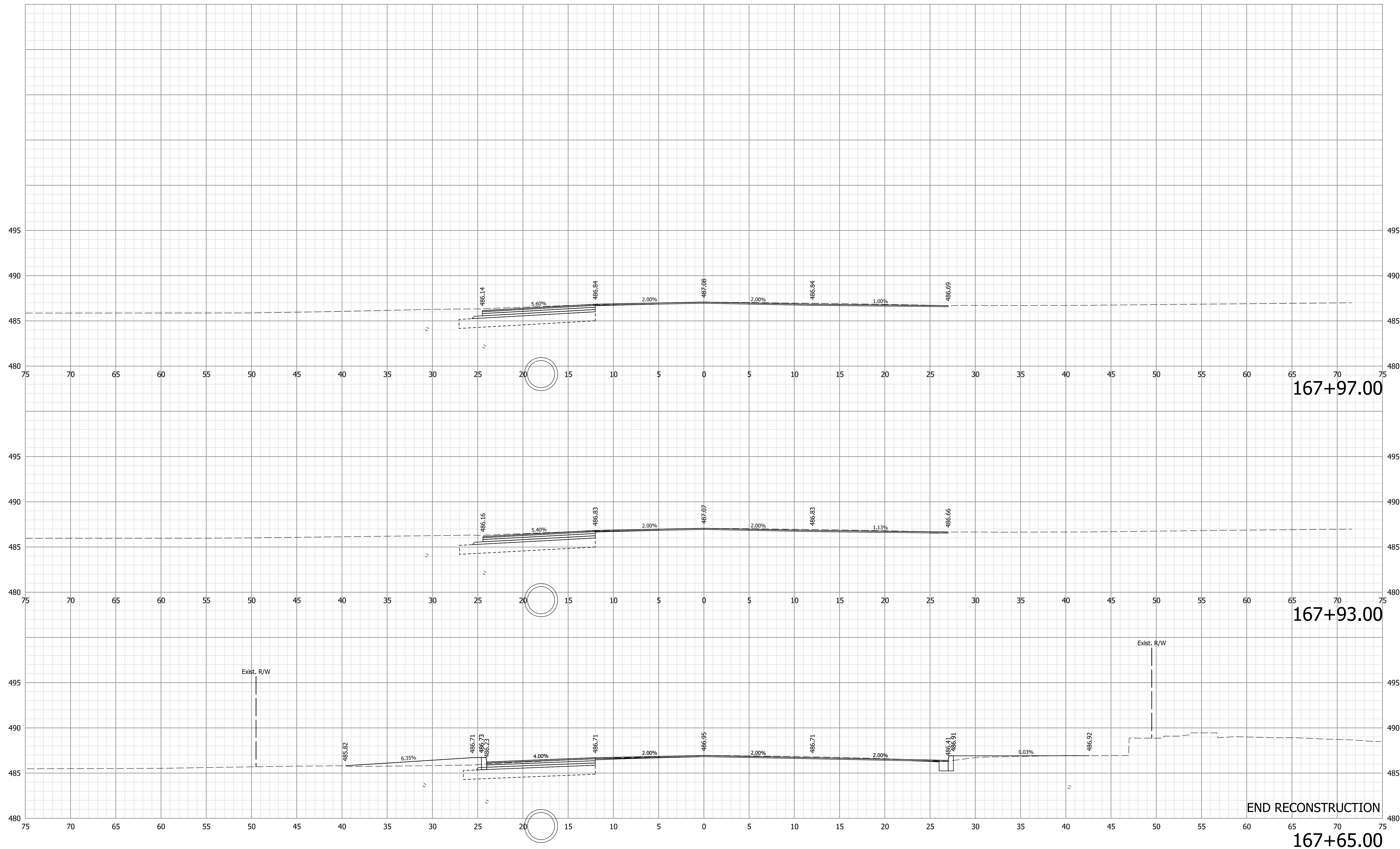

Note:  
 1. All utilities information shall be considered QL-D unless otherwise indicated and is for informational purposes only. The Contractor is responsible for locating and coordinating with utility companies in accordance with the plans and specifications.

**NOT FOR CONSTRUCTION**

RECOMMENDED FOR APPROVAL	DESIGN ENGINEER	6/9/2021	DATE
DESIGNED: WCM	6/9/2021	DRAWN: WCM	6/9/2021
CHECKED: LNB	6/9/2021	CHECKED: LNB	6/9/2021

INDIANA  
 DEPARTMENT OF TRANSPORTATION

CROSS SECTIONS  
 LINE "B"

HORIZONTAL SCALE	BRIDGE FILE
1" = 5'	N/A
VERTICAL SCALE	DESIGNATION
1" = 5'	1900334
SURVEY BOOK	SHEETS
Electronic	20 of 89
CONTRACT	PROJECT
R-42228	1900334

Plot: 6/9/2021 7:56:57 PM

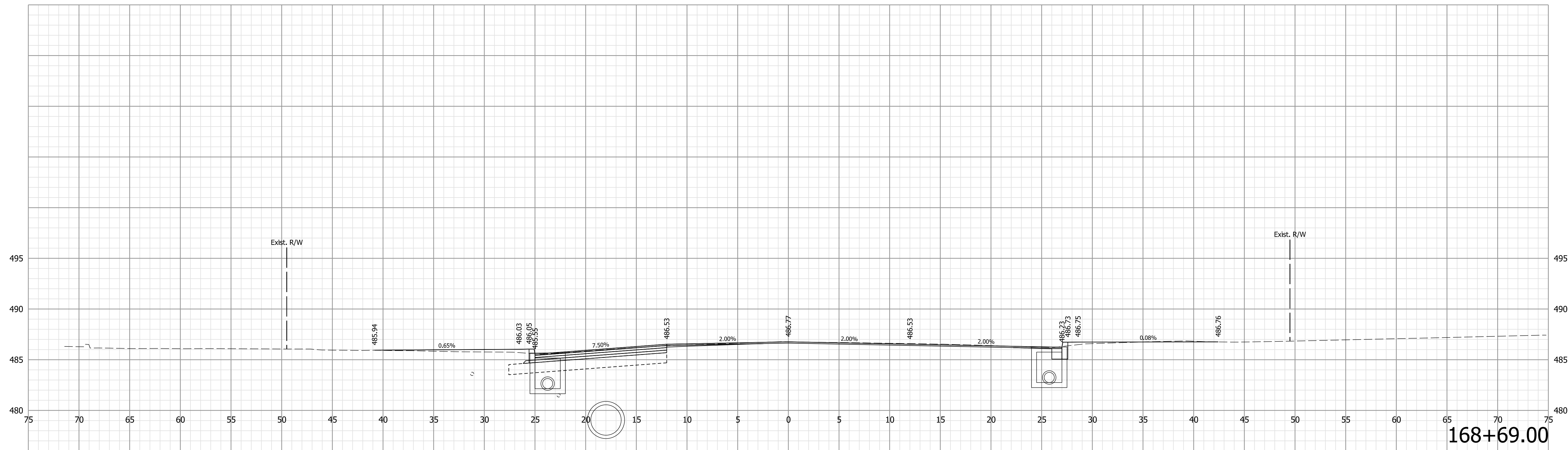

168+69.00

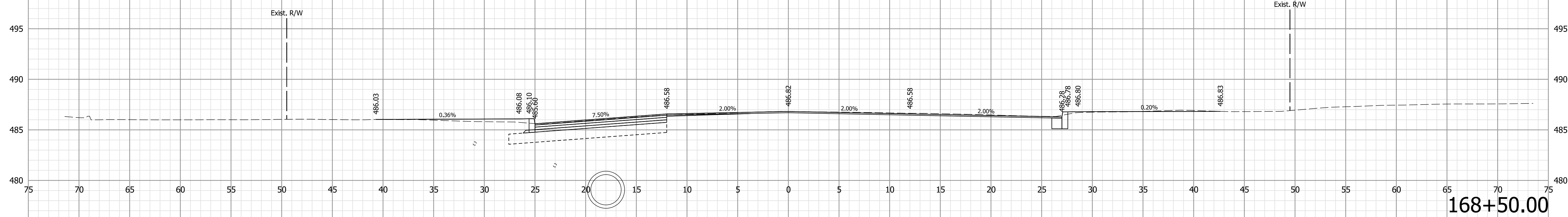

168+50.00

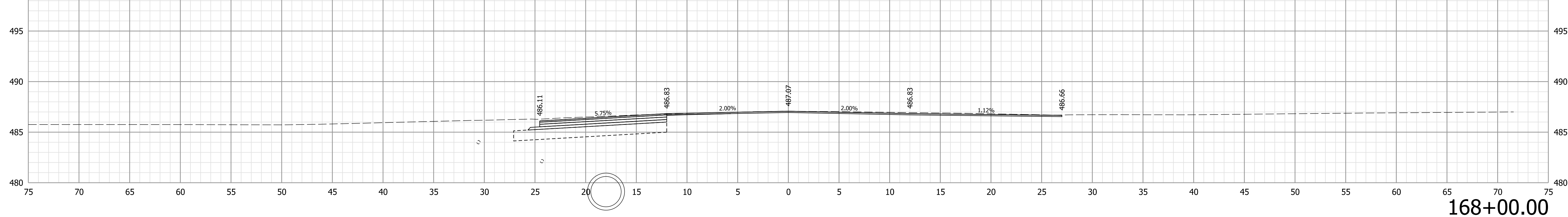

168+00.00

Note:  
 1. All utilities information shall be considered QL-D unless otherwise indicated and is for informational purposes only. The Contractor is responsible for locating and coordinating with utility companies in accordance with the plans and specifications.

**NOT FOR CONSTRUCTION**

RECOMMENDED FOR APPROVAL	DESIGN ENGINEER	6/9/2021	DATE
DESIGNED: WCM	6/9/2021	DRAWN: WCM	6/9/2021
CHECKED: LNB	6/9/2021	CHECKED: LNB	6/9/2021

INDIANA  
 DEPARTMENT OF TRANSPORTATION

CROSS SECTIONS  
 LINE "B"

HORIZONTAL SCALE	BRIDGE FILE
1" = 5'	N/A
VERTICAL SCALE	DESIGNATION
1" = 5'	1900334
SURVEY BOOK	SHEETS
Electronic	21 of 89
CONTRACT	PROJECT
R-42228	1900334

Plot: 6/9/2021 7:57:00 PM

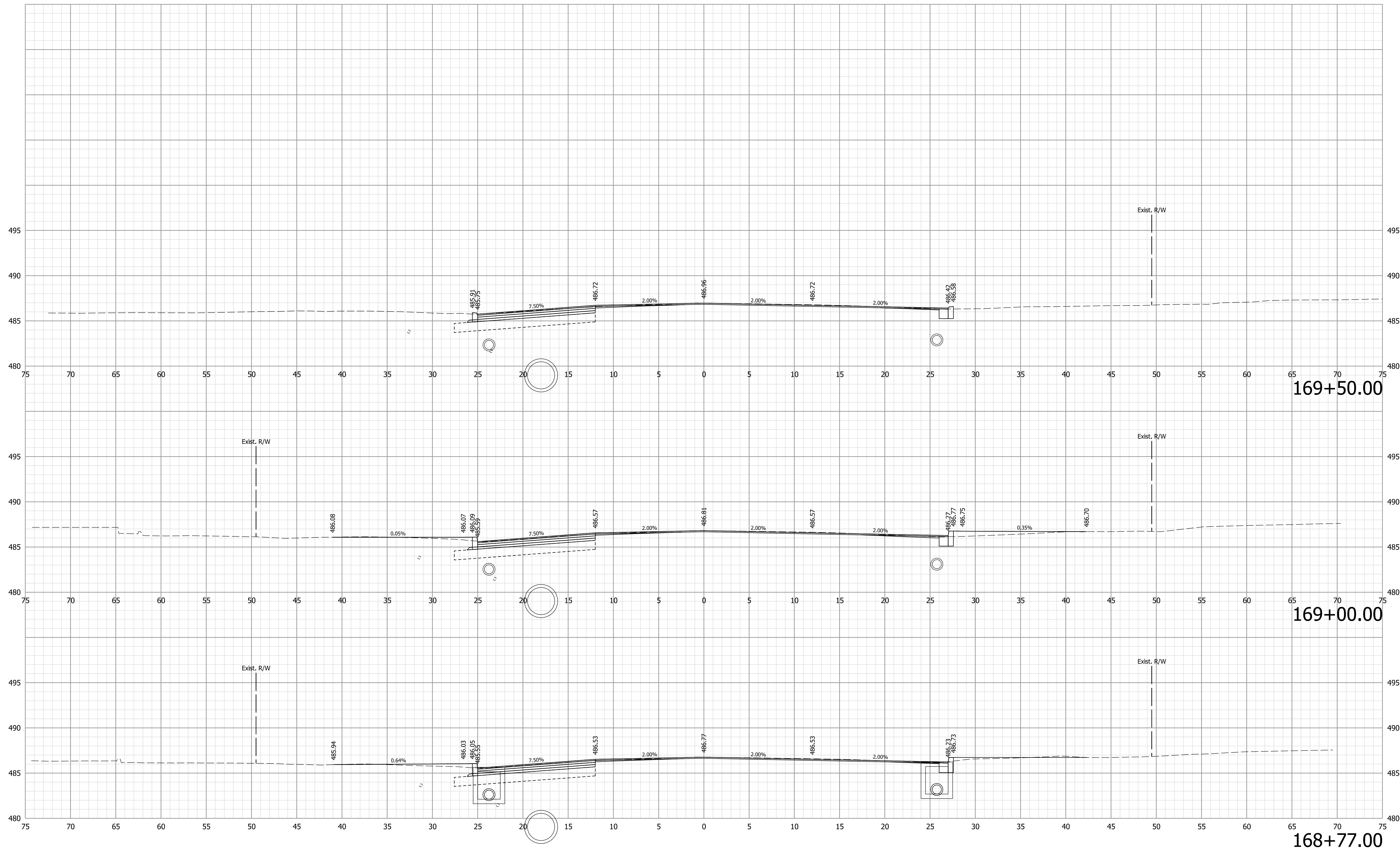

Note:  
 1. All utilities information shall be considered QL-D unless otherwise indicated and is for informational purposes only. The Contractor is responsible for locating and coordinating with utility companies in accordance with the plans and specifications.

**NOT FOR CONSTRUCTION**

RECOMMENDED FOR APPROVAL	DESIGN ENGINEER	6/9/2021	DATE
DESIGNED: WCM	6/9/2021	DRAWN: WCM	6/9/2021
CHECKED: LNB	6/9/2021	CHECKED: LNB	6/9/2021

INDIANA  
DEPARTMENT OF TRANSPORTATION

CROSS SECTIONS  
LINE "B"

HORIZONTAL SCALE	BRIDGE FILE
1" = 5'	N/A
VERTICAL SCALE	DESIGNATION
1" = 5'	1900334
SURVEY BOOK	SHEETS
Electronic	22 of 89
CONTRACT	PROJECT
R-42228	1900334

Plot: 6/9/2021 7:57:03 PM

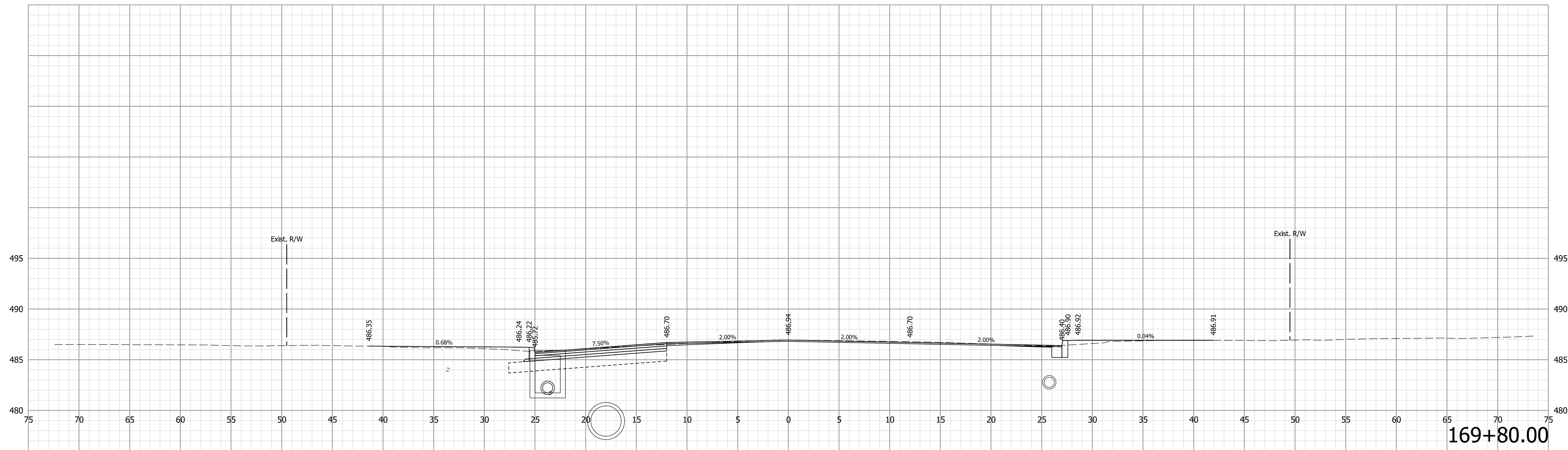

169+80.00

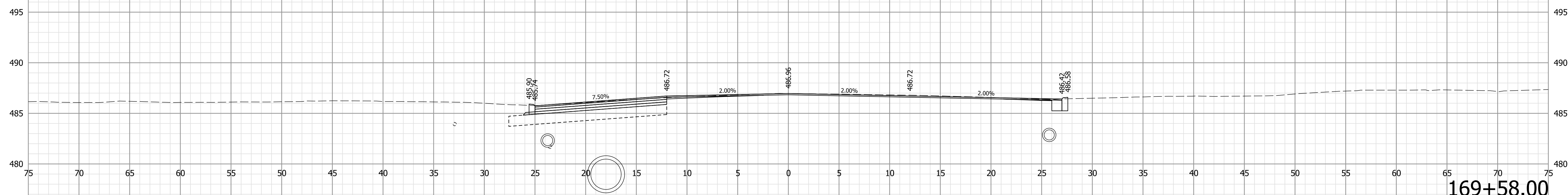

169+58.00

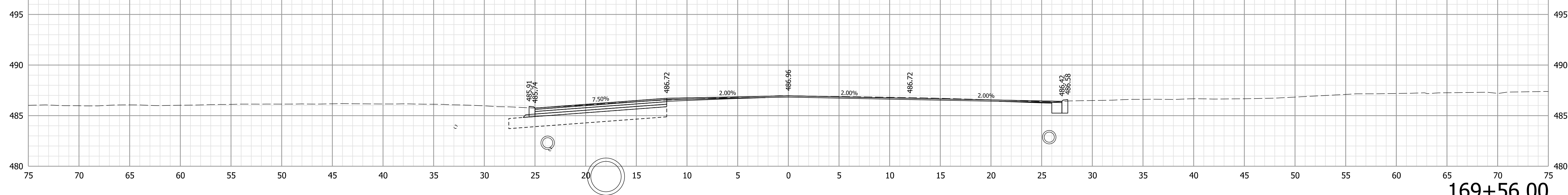

169+56.00

Note:  
 1. All utilities information shall be considered QL-D unless otherwise indicated and is for informational purposes only. The Contractor is responsible for locating and coordinating with utility companies in accordance with the plans and specifications.

**NOT FOR CONSTRUCTION**

RECOMMENDED FOR APPROVAL	DESIGN ENGINEER	6/9/2021	DATE
DESIGNED: WCM	6/9/2021	DRAWN: WCM	6/9/2021
CHECKED: LNB	6/9/2021	CHECKED: LNB	6/9/2021

INDIANA  
DEPARTMENT OF TRANSPORTATION

CROSS SECTIONS  
LINE "B"

HORIZONTAL SCALE	BRIDGE FILE
1" = 5'	N/A
VERTICAL SCALE	DESIGNATION
1" = 5'	1900334
SURVEY BOOK	SHEETS
Electronic	23 of 89
CONTRACT	PROJECT
R-42228	1900334

Plot: 6/9/2021 7:57:06 PM

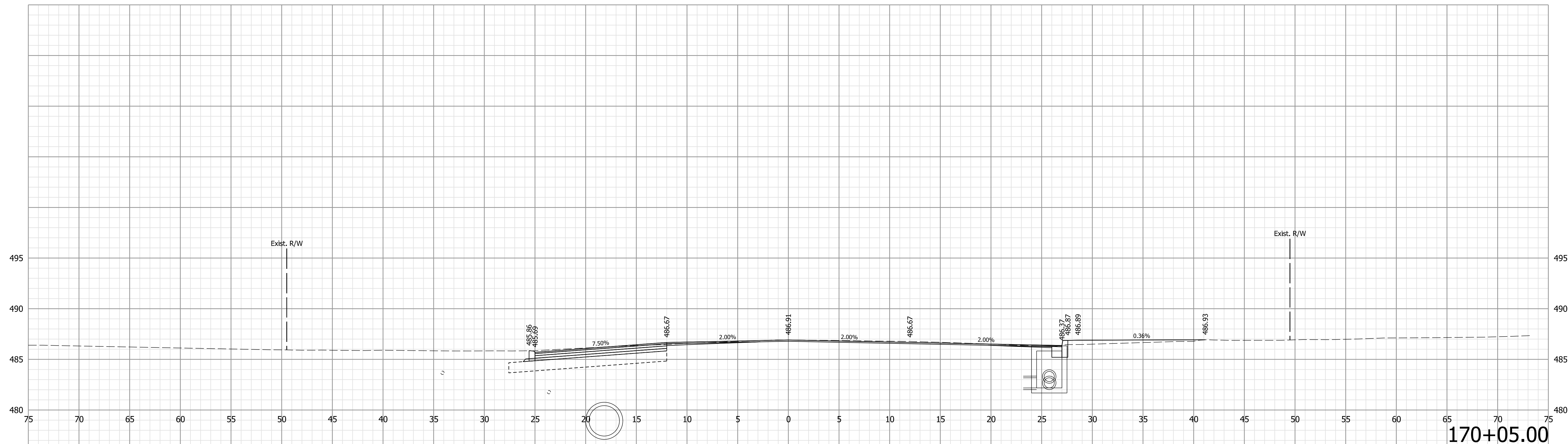

170+05.00

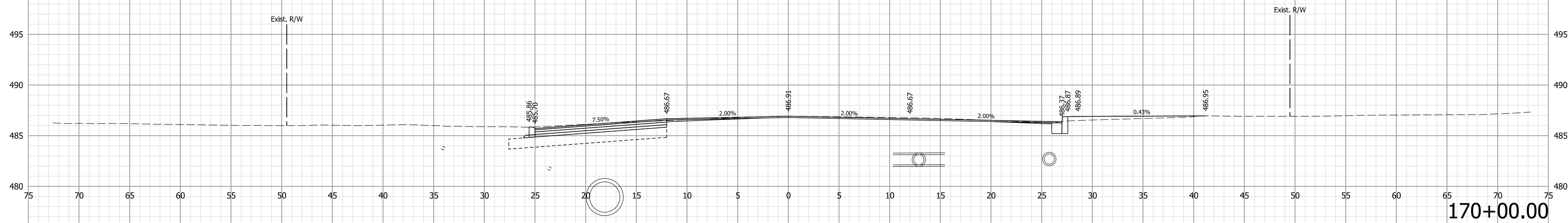

170+00.00

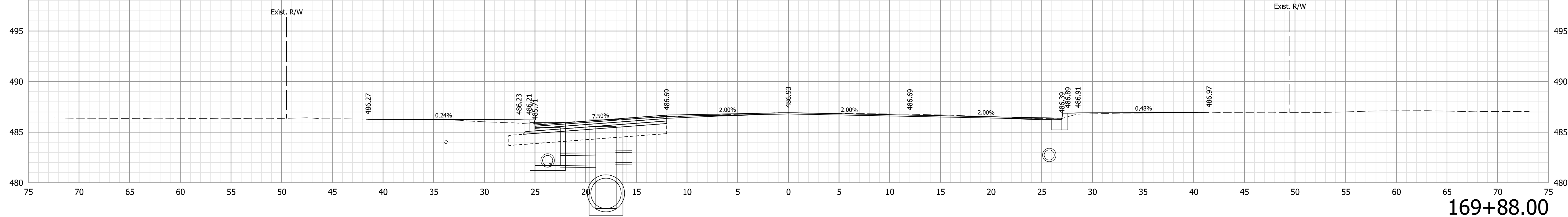

169+88.00

Note:

- All utilities information shall be considered QL-D unless otherwise indicated and is for informational purposes only. The Contractor is responsible for locating and coordinating with utility companies in accordance with the plans and specifications.

**NOT FOR CONSTRUCTION**

RECOMMENDED FOR APPROVAL	DESIGN ENGINEER	6/9/2021	DATE
DESIGNED: WCM	6/9/2021	DRAWN: WCM	6/9/2021
CHECKED: LNB	6/9/2021	CHECKED: LNB	6/9/2021

INDIANA  
DEPARTMENT OF TRANSPORTATION

CROSS SECTIONS  
LINE "B"

HORIZONTAL SCALE	BRIDGE FILE
1" = 5'	N/A
VERTICAL SCALE	DESIGNATION
1" = 5'	1900334
SURVEY BOOK	SHEETS
Electronic	24 of 89
CONTRACT	PROJECT
R-42228	1900334

Plot: 6/9/2021 7:57:08 PM



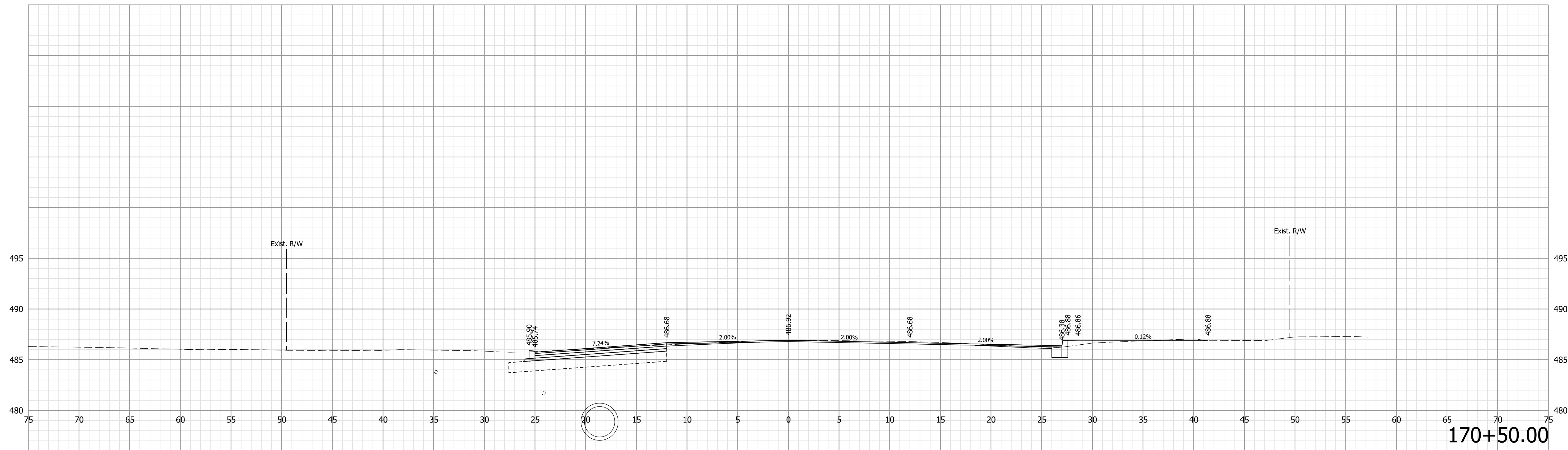

170+50.00

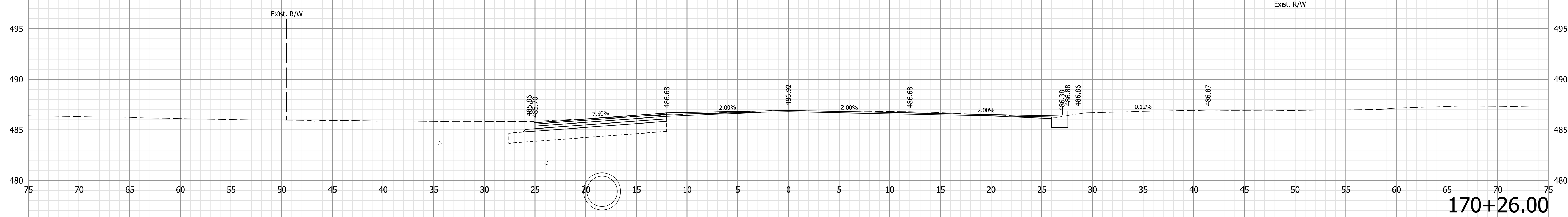

170+26.00

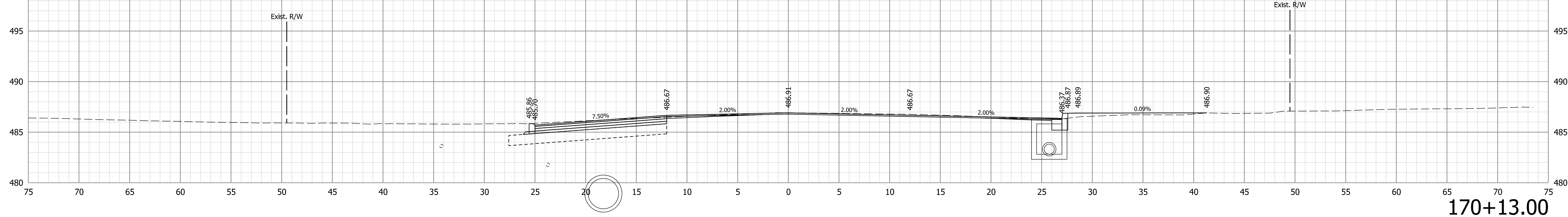

170+13.00

Note:  
 1. All utilities information shall be considered QL-D unless otherwise indicated and is for informational purposes only. The Contractor is responsible for locating and coordinating with utility companies in accordance with the plans and specifications.

**NOT FOR CONSTRUCTION**

RECOMMENDED FOR APPROVAL	DESIGN ENGINEER	6/9/2021	DATE
DESIGNED: WCM	6/9/2021	DRAWN: WCM	6/9/2021
CHECKED: LNB	6/9/2021	CHECKED: LNB	6/9/2021

INDIANA  
DEPARTMENT OF TRANSPORTATION

CROSS SECTIONS  
LINE "B"

HORIZONTAL SCALE	BRIDGE FILE
1" = 5'	N/A
VERTICAL SCALE	DESIGNATION
1" = 5'	1900334
SURVEY BOOK	SHEETS
Electronic	25 of 89
CONTRACT	PROJECT
R-42228	1900334

Plot: 6/9/2021 7:57:11 PM

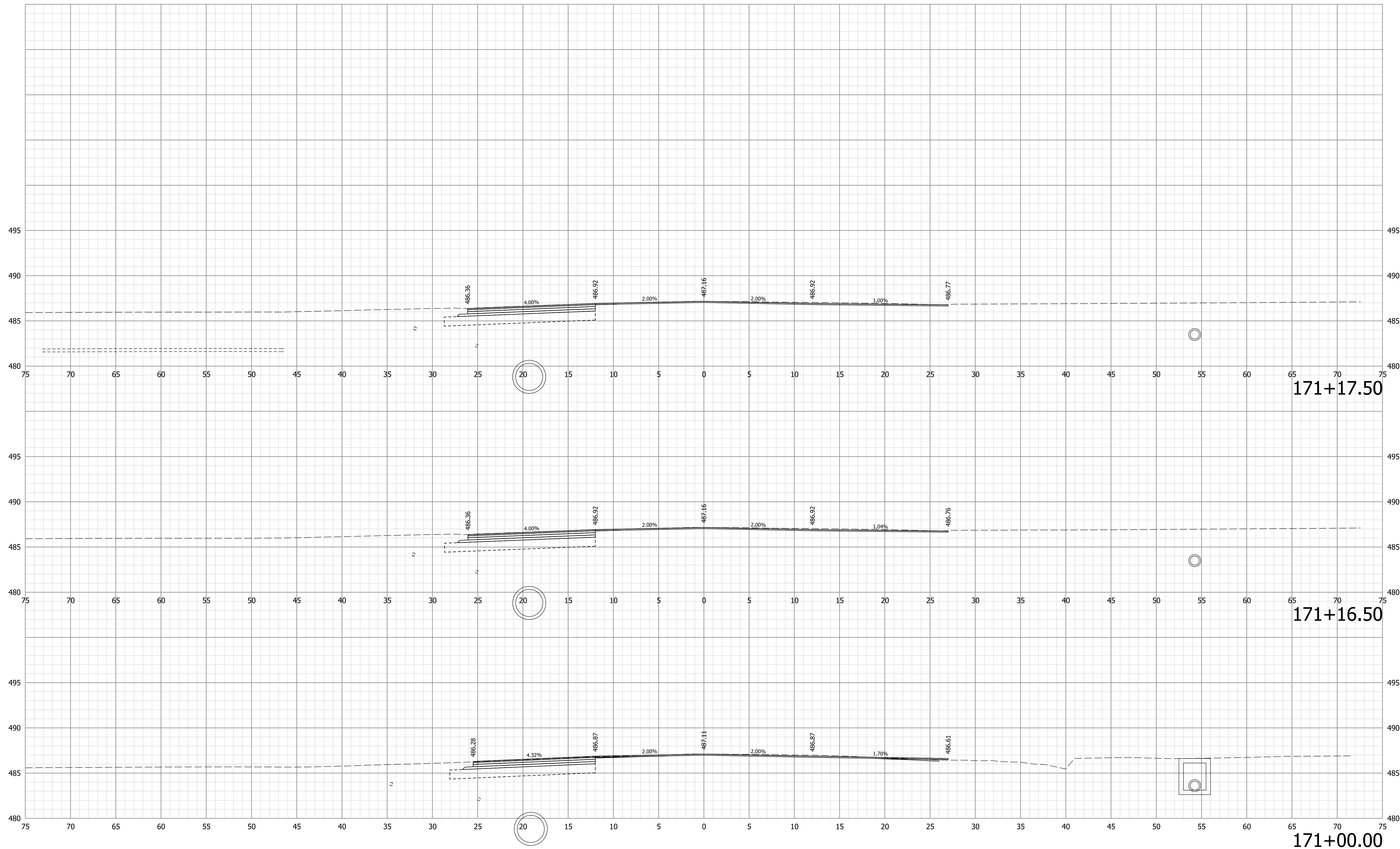

Note:  
 1. All utilities information shall be considered QL-D unless otherwise indicated and is for informational purposes only. The Contractor is responsible for locating and coordinating with utility companies in accordance with the plans and specifications.

**NOT FOR CONSTRUCTION**

RECOMMENDED FOR APPROVAL	DESIGN ENGINEER	6/9/2021	DATE
DESIGNED: WCM	6/9/2021	DRAWN: WCM	6/9/2021
CHECKED: LNB	6/9/2021	CHECKED: LNB	6/9/2021

INDIANA  
 DEPARTMENT OF TRANSPORTATION

CROSS SECTIONS  
 LINE "B"

HORIZONTAL SCALE	BRIDGE FILE
1" = 5'	N/A
VERTICAL SCALE	DESIGNATION
1" = 5'	1900334
SURVEY BOOK	SHEETS
Electronic	26 of 89
CONTRACT	PROJECT
R-42228	1900334

Plot: 6/9/2021 7:57:14 PM

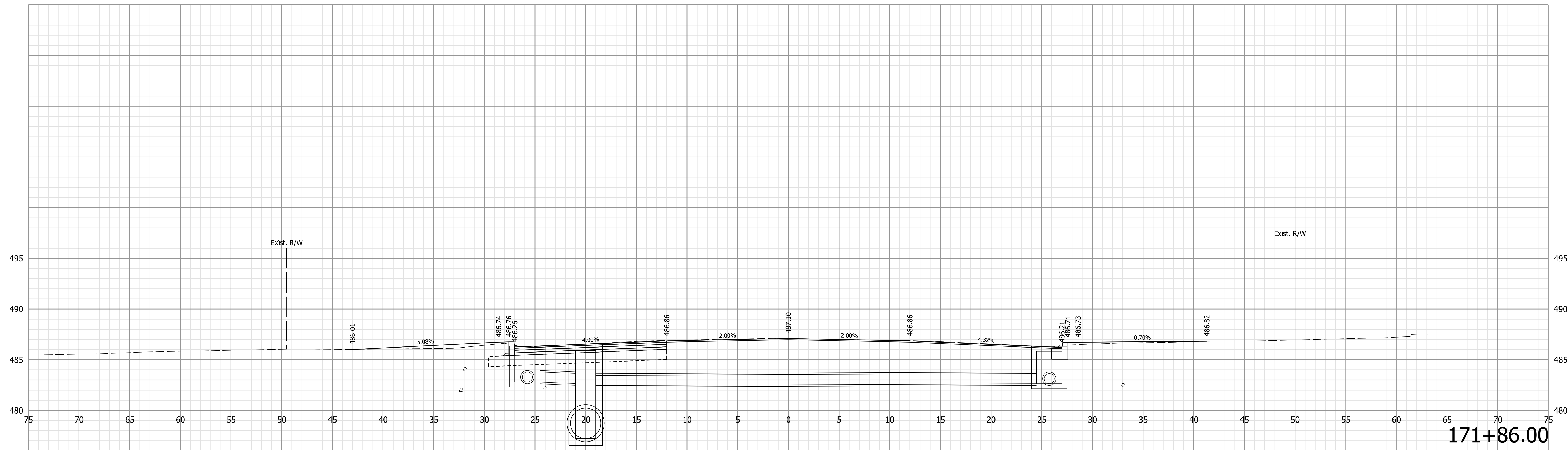

171+86.00

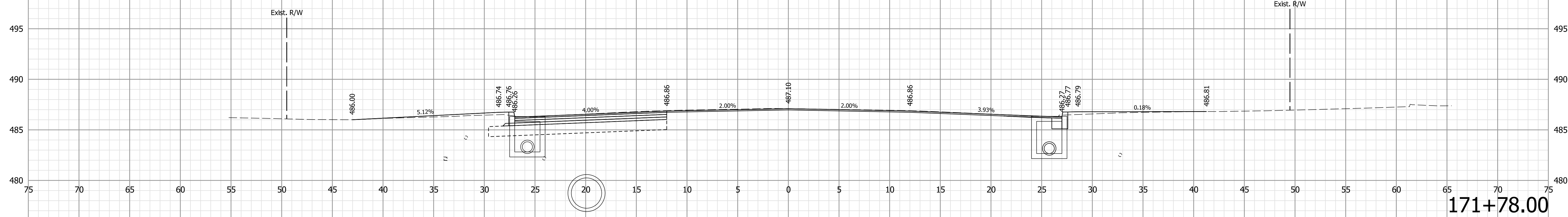

171+78.00

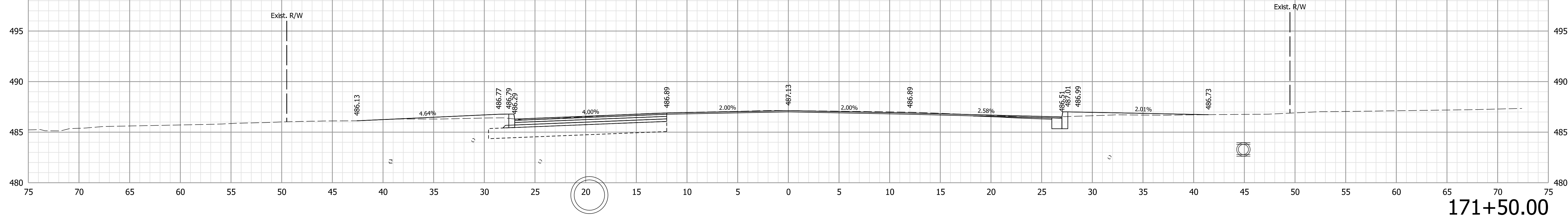

171+50.00

Note:  
 1. All utilities information shall be considered QL-D unless otherwise indicated and is for informational purposes only. The Contractor is responsible for locating and coordinating with utility companies in accordance with the plans and specifications.

**NOT FOR CONSTRUCTION**

RECOMMENDED FOR APPROVAL	DESIGN ENGINEER	6/9/2021	DATE
DESIGNED: WCM	6/9/2021	DRAWN: WCM	6/9/2021
CHECKED: LNB	6/9/2021	CHECKED: LNB	6/9/2021

INDIANA  
DEPARTMENT OF TRANSPORTATION

CROSS SECTIONS  
LINE "B"

HORIZONTAL SCALE	BRIDGE FILE
1" = 5'	N/A
VERTICAL SCALE	DESIGNATION
1" = 5'	1900334
SURVEY BOOK	SHEETS
Electronic	27 of 89
CONTRACT	PROJECT
R-42228	1900334

Plot: 6/9/2021 7:57:17 PM

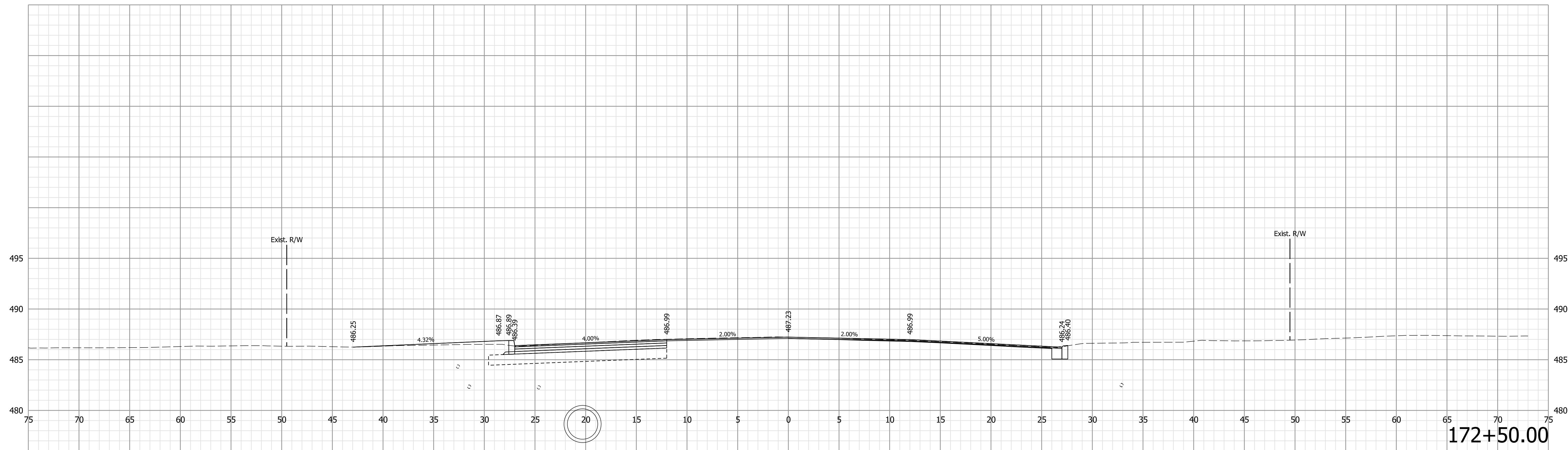

172+50.00

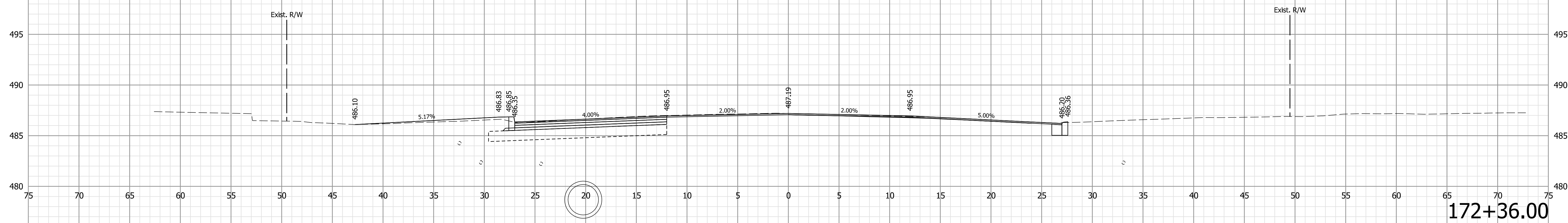

172+36.00

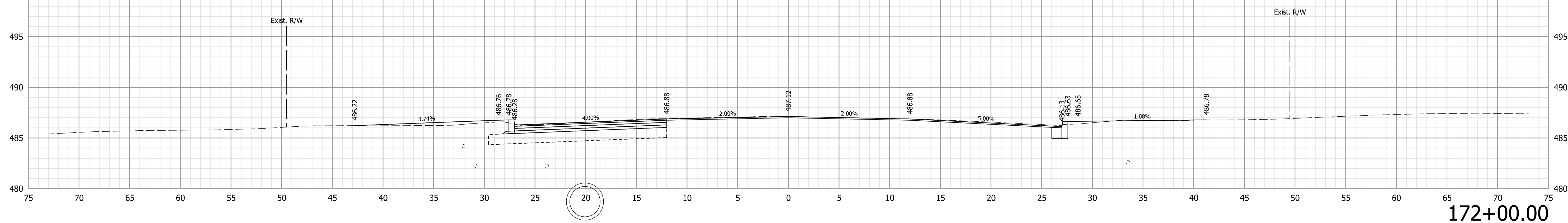

172+00.00

Note:  
 1. All utilities information shall be considered QL-D unless otherwise indicated and is for informational purposes only. The Contractor is responsible for locating and coordinating with utility companies in accordance with the plans and specifications.

**NOT FOR CONSTRUCTION**

RECOMMENDED FOR APPROVAL	DESIGN ENGINEER	6/9/2021	DATE
DESIGNED: WCM	6/9/2021	DRAWN: WCM	6/9/2021
CHECKED: LNB	6/9/2021	CHECKED: LNB	6/9/2021

INDIANA  
 DEPARTMENT OF TRANSPORTATION

CROSS SECTIONS  
 LINE "B"

HORIZONTAL SCALE	BRIDGE FILE
1" = 5'	N/A
VERTICAL SCALE	DESIGNATION
1" = 5'	1900334
SURVEY BOOK	SHEETS
Electronic	28 of 89
CONTRACT	PROJECT
R-42228	1900334

Pct: 6/9/2021 7:57:20 PM

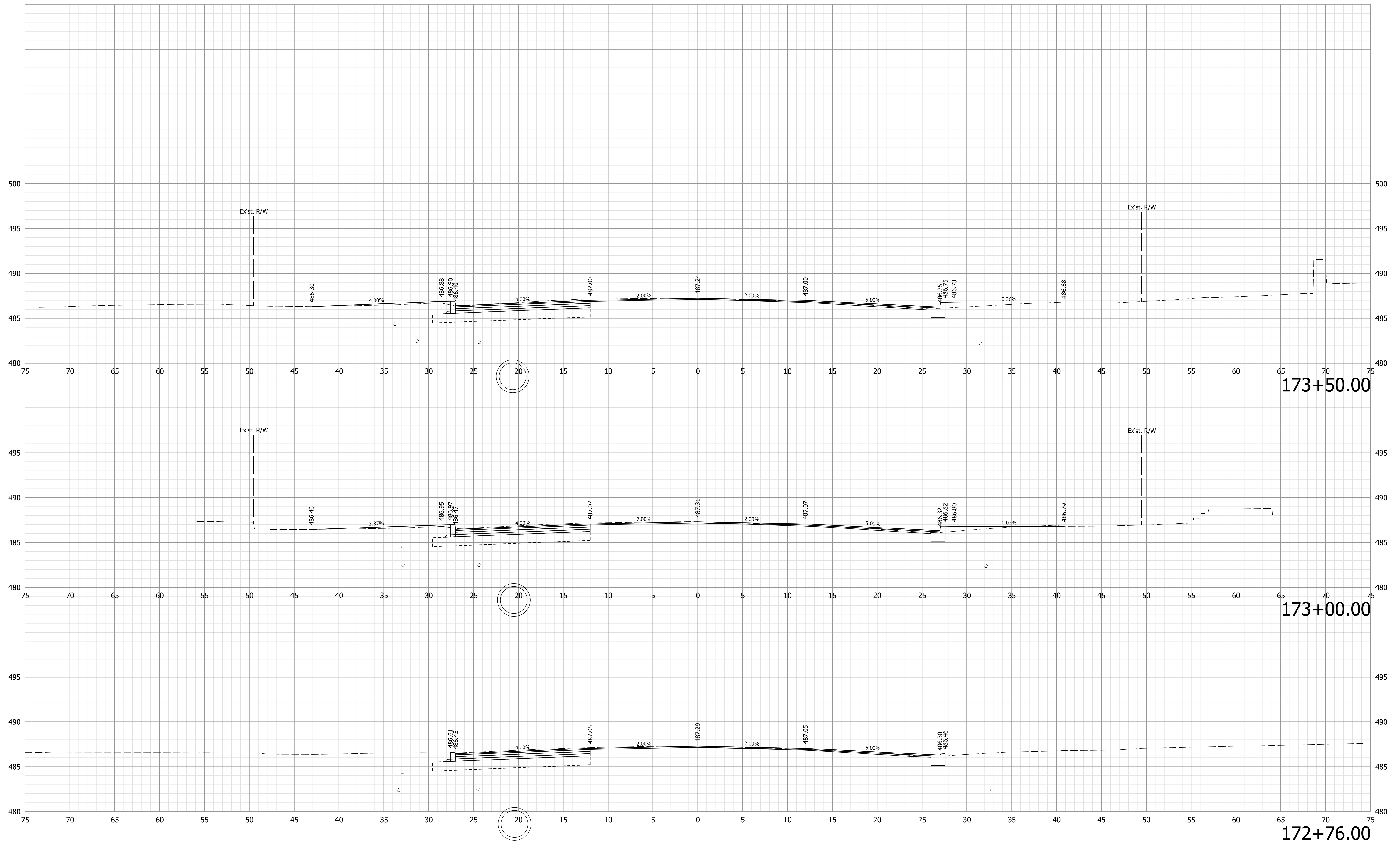

Note:  
 1. All utilities information shall be considered QL-D unless otherwise indicated and is for informational purposes only. The Contractor is responsible for locating and coordinating with utility companies in accordance with the plans and specifications.

**NOT FOR CONSTRUCTION**

RECOMMENDED FOR APPROVAL	DESIGN ENGINEER	6/9/2021	DATE
DESIGNED: WCM	6/9/2021	DRAWN: WCM	6/9/2021
CHECKED: LNB	6/9/2021	CHECKED: LNB	6/9/2021

INDIANA  
DEPARTMENT OF TRANSPORTATION

CROSS SECTIONS  
LINE "B"

HORIZONTAL SCALE	BRIDGE FILE
1" = 5'	N/A
VERTICAL SCALE	DESIGNATION
1" = 5'	1900334
SURVEY BOOK	SHEETS
Electronic	29 of 89
CONTRACT	PROJECT
R-42228	1900334

Plot: 6/9/2021 7:57:23 PM

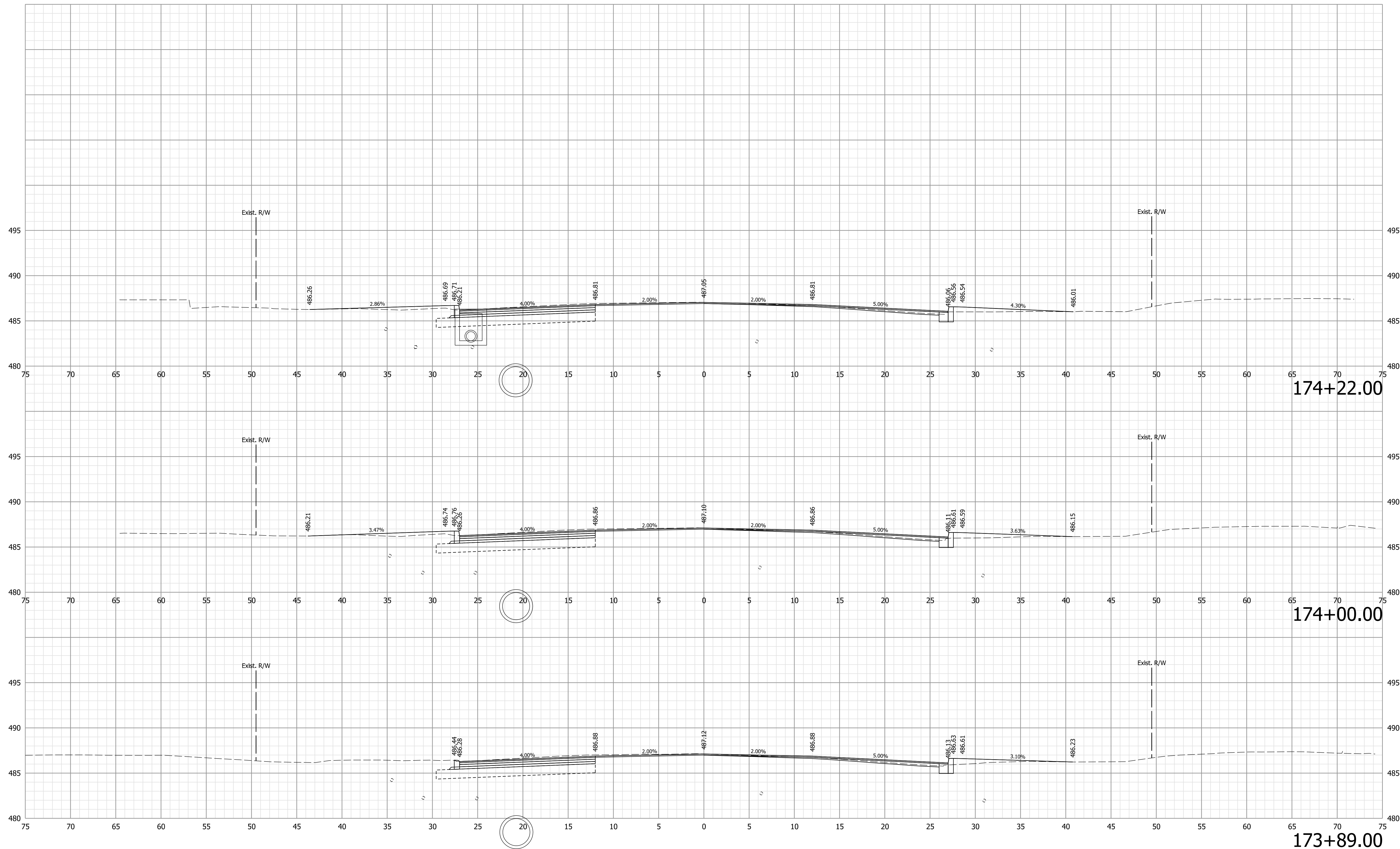

Note:  
 1. All utilities information shall be considered QL-D unless otherwise indicated and is for informational purposes only. The Contractor is responsible for locating and coordinating with utility companies in accordance with the plans and specifications.

**NOT FOR CONSTRUCTION**

RECOMMENDED FOR APPROVAL	DESIGN ENGINEER	6/9/2021	DATE
DESIGNED: WCM	6/9/2021	DRAWN: WCM	6/9/2021
CHECKED: LNB	6/9/2021	CHECKED: LNB	6/9/2021

INDIANA  
DEPARTMENT OF TRANSPORTATION

CROSS SECTIONS  
LINE "B"

HORIZONTAL SCALE	BRIDGE FILE
1" = 5'	N/A
VERTICAL SCALE	DESIGNATION
1" = 5'	1900334
SURVEY BOOK	SHEETS
Electronic	30 of 89
CONTRACT	PROJECT
R-42228	1900334

Plot: 6/9/2021 7:57:25 PM

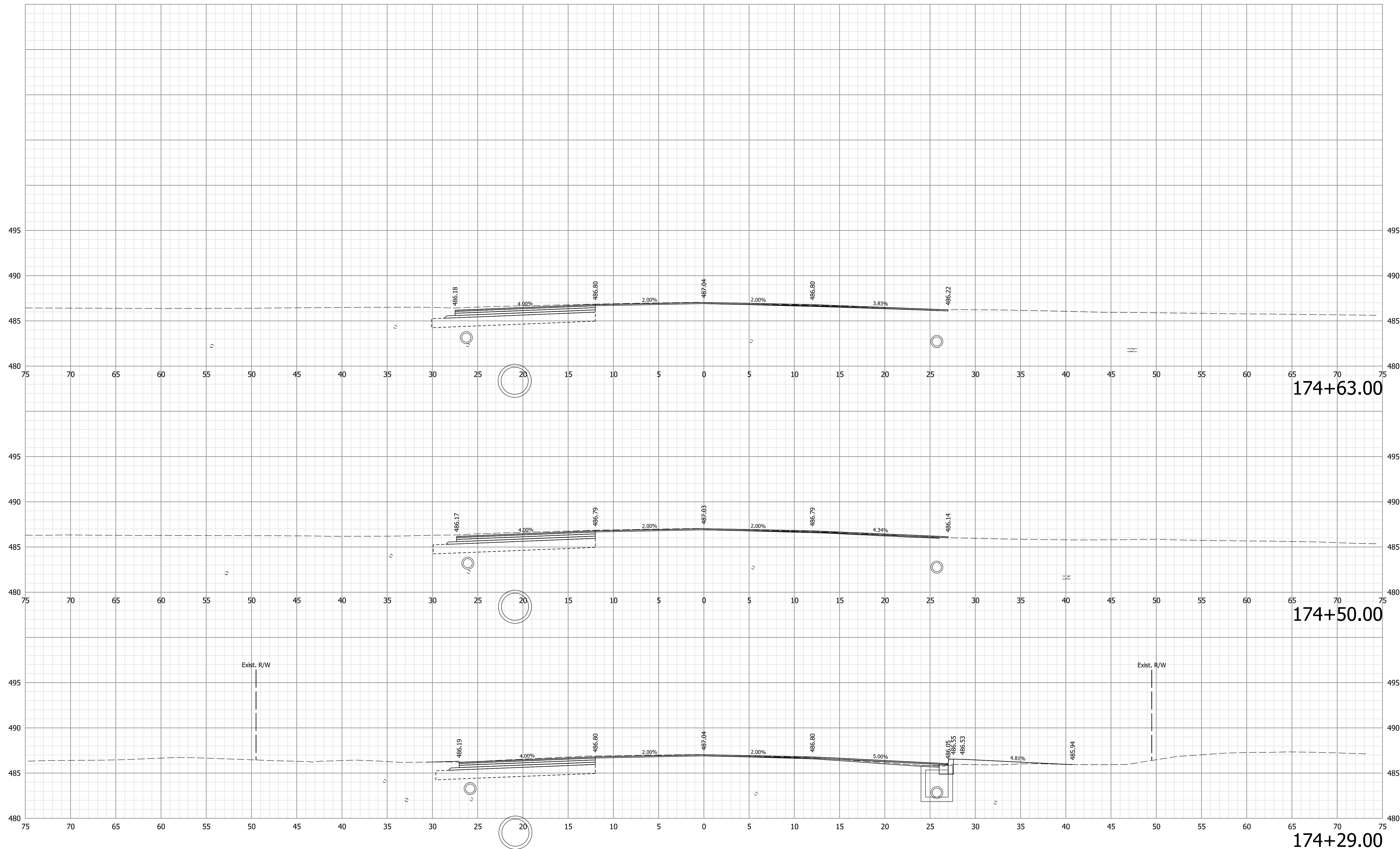

Note:  
 1. All utilities information shall be considered QL-D unless otherwise indicated and is for informational purposes only. The Contractor is responsible for locating and coordinating with utility companies in accordance with the plans and specifications.

**NOT FOR CONSTRUCTION**

RECOMMENDED FOR APPROVAL	DESIGN ENGINEER	6/9/2021	DATE
DESIGNED: WCM	6/9/2021	DRAWN: WCM	6/9/2021
CHECKED: LNB	6/9/2021	CHECKED: LNB	6/9/2021

INDIANA  
DEPARTMENT OF TRANSPORTATION

CROSS SECTIONS  
LINE "B"

HORIZONTAL SCALE	BRIDGE FILE
1" = 5'	N/A
VERTICAL SCALE	DESIGNATION
1" = 5'	1900334
SURVEY BOOK	SHEETS
Electronic	31 of 89
CONTRACT	PROJECT
R-42228	1900334

Plot: 6/9/2021 7:57:28 PM

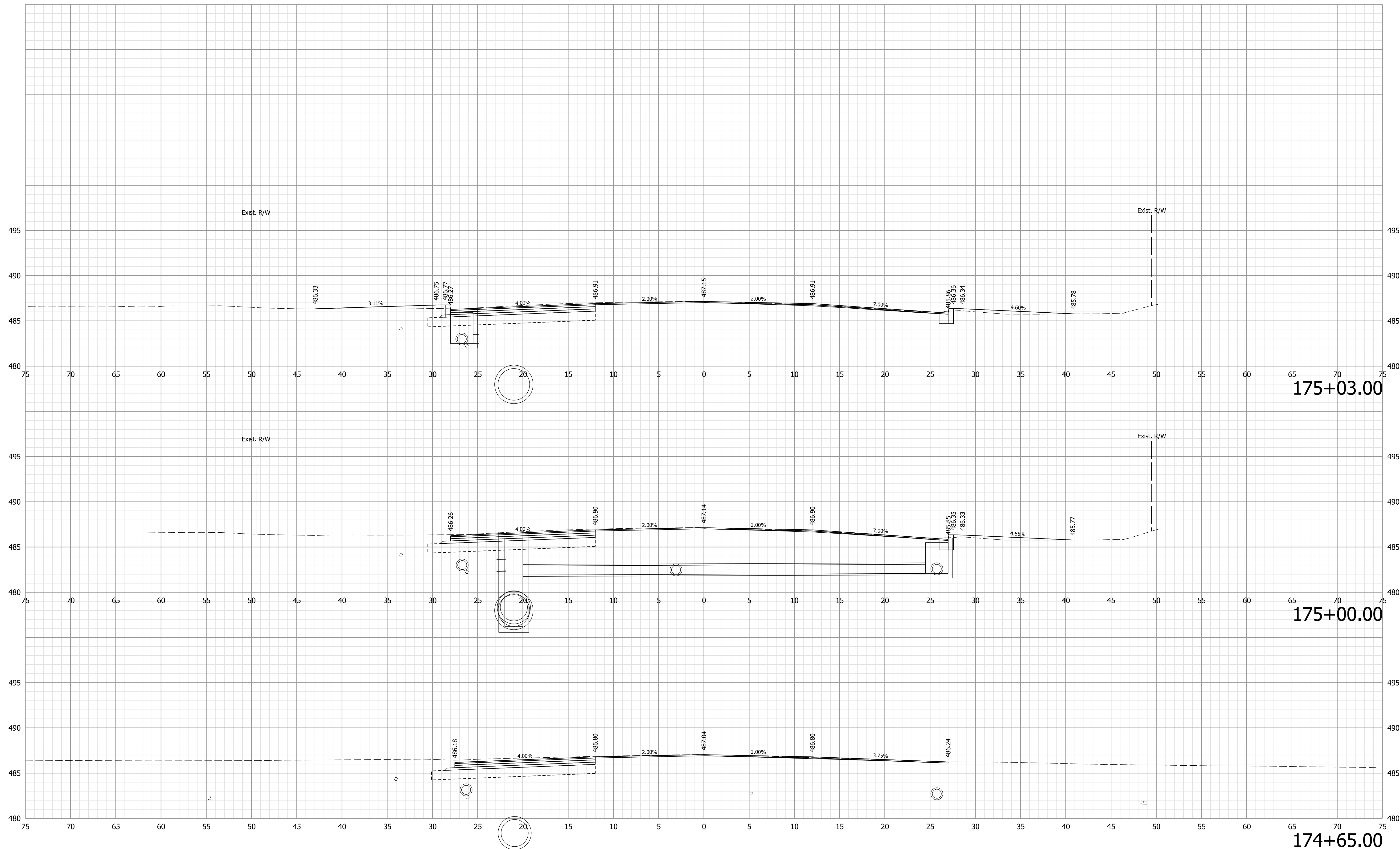

175+03.00

175+00.00

174+65.00

Note:  
 1. All utilities information shall be considered QL-D unless otherwise indicated and is for informational purposes only. The Contractor is responsible for locating and coordinating with utility companies in accordance with the plans and specifications.

**NOT FOR CONSTRUCTION**

RECOMMENDED FOR APPROVAL	DESIGN ENGINEER	6/9/2021	DATE
DESIGNED: WCM	6/9/2021	DRAWN: WCM	6/9/2021
CHECKED: LNB	6/9/2021	CHECKED: LNB	6/9/2021

INDIANA  
 DEPARTMENT OF TRANSPORTATION  
  
 CROSS SECTIONS  
 LINE "B"

HORIZONTAL SCALE	BRIDGE FILE
1" = 5'	N/A
VERTICAL SCALE	DESIGNATION
1" = 5'	1900334
SURVEY BOOK	SHEETS
Electronic	32 of 89
CONTRACT	PROJECT
R-42228	1900334

Plot: 6/9/2021 7:57:31 PM



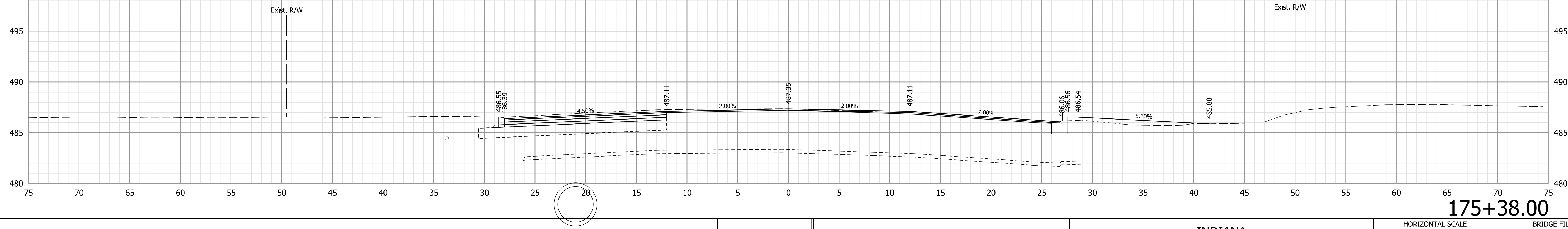
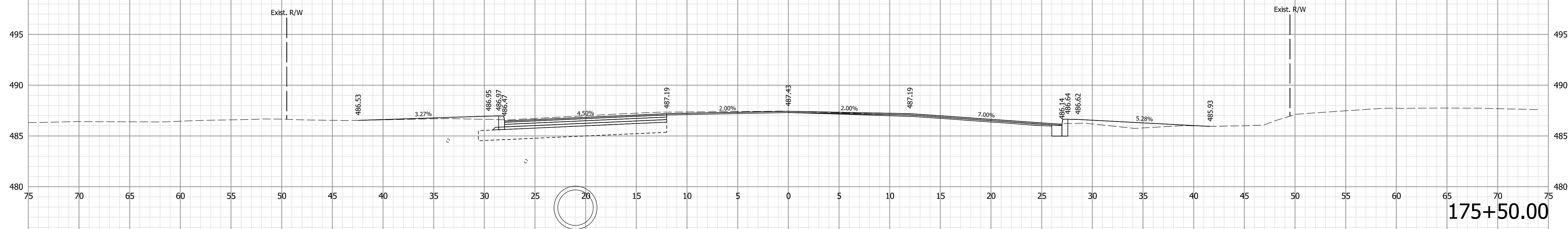
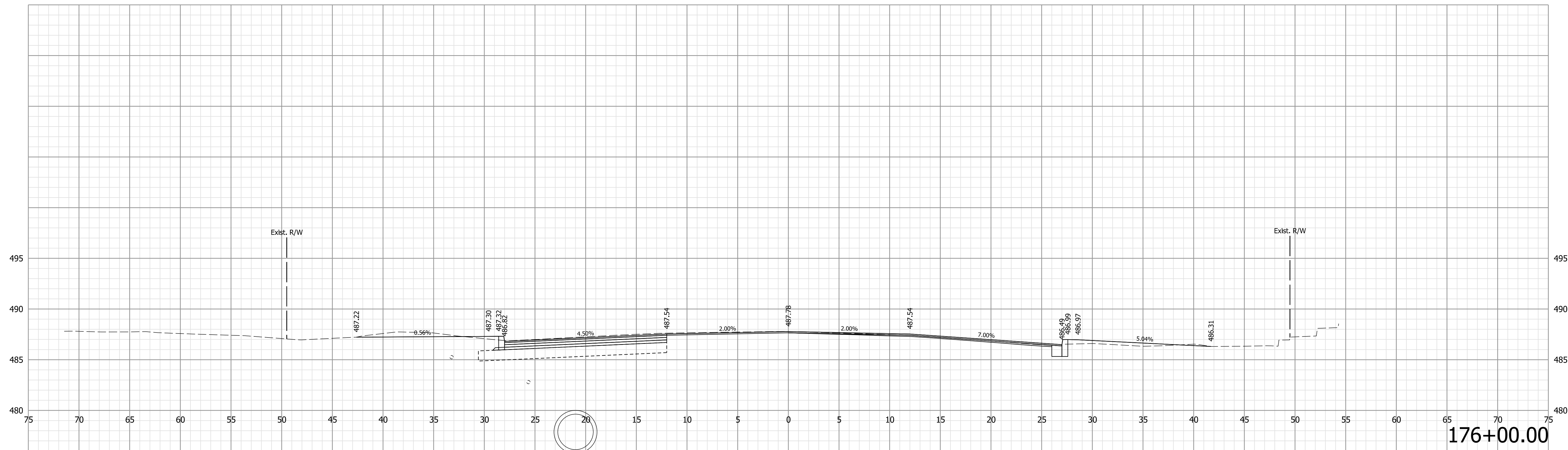

Note:  
 1. All utilities information shall be considered QL-D unless otherwise indicated and is for informational purposes only. The Contractor is responsible for locating and coordinating with utility companies in accordance with the plans and specifications.

**NOT FOR CONSTRUCTION**

RECOMMENDED FOR APPROVAL	DESIGN ENGINEER	6/9/2021	DATE
DESIGNED: WCM	6/9/2021	DRAWN: WCM	6/9/2021
CHECKED: LNB	6/9/2021	CHECKED: LNB	6/9/2021

INDIANA  
DEPARTMENT OF TRANSPORTATION

CROSS SECTIONS  
LINE "B"

HORIZONTAL SCALE	BRIDGE FILE
1" = 5'	N/A
VERTICAL SCALE	DESIGNATION
1" = 5'	1900334
SURVEY BOOK	SHEETS
Electronic	33 of 89
CONTRACT	PROJECT
R-42228	1900334

Plot: 6/9/2021 7:57:34 PM

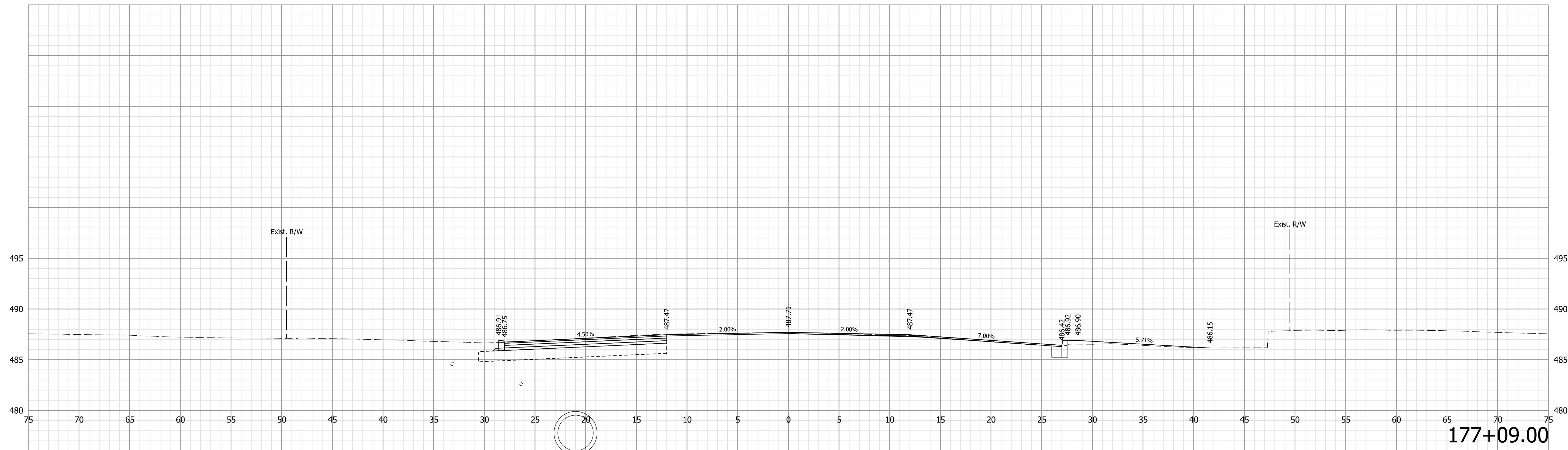

177+09.00

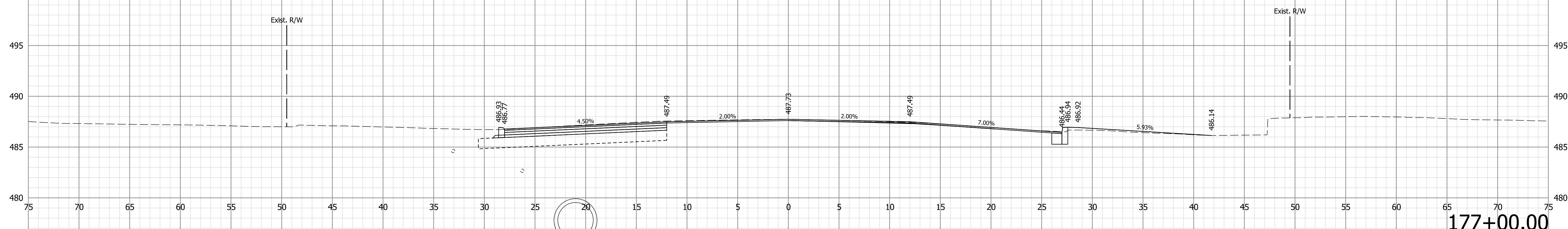

177+00.00

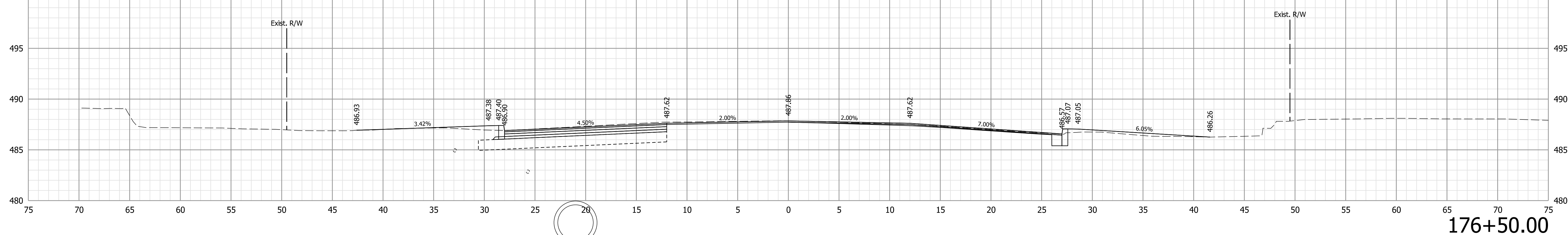

176+50.00

Note:  
 1. All utilities information shall be considered QL-D unless otherwise indicated and is for informational purposes only. The Contractor is responsible for locating and coordinating with utility companies in accordance with the plans and specifications.

**NOT FOR CONSTRUCTION**

RECOMMENDED FOR APPROVAL	DESIGN ENGINEER	6/9/2021	DATE
DESIGNED: WCM	6/9/2021	DRAWN: WCM	6/9/2021
CHECKED: LNB	6/9/2021	CHECKED: LNB	6/9/2021

INDIANA  
DEPARTMENT OF TRANSPORTATION

CROSS SECTIONS  
LINE "B"

HORIZONTAL SCALE	BRIDGE FILE
1" = 5'	N/A
VERTICAL SCALE	DESIGNATION
1" = 5'	1900334
SURVEY BOOK	SHEETS
Electronic	34 of 89
CONTRACT	PROJECT
R-42228	1900334

Plot: 6/9/2021 7:57:37 PM

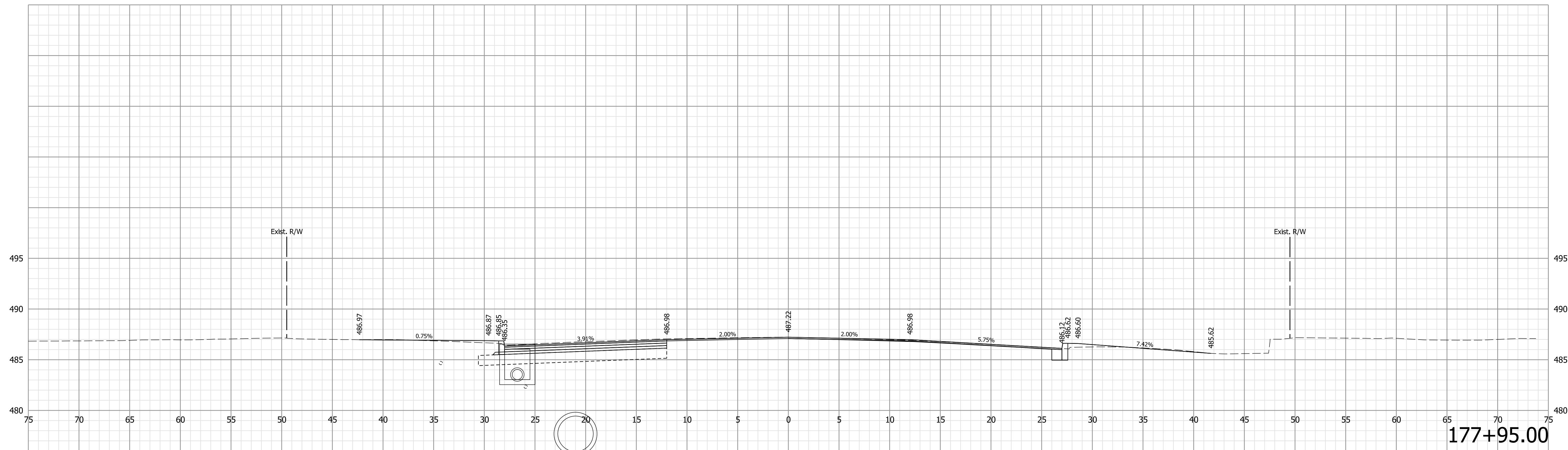

177+95.00

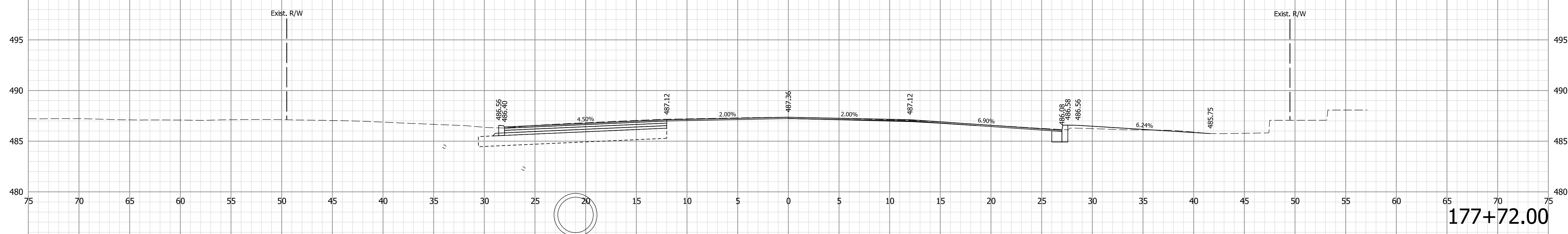

177+72.00

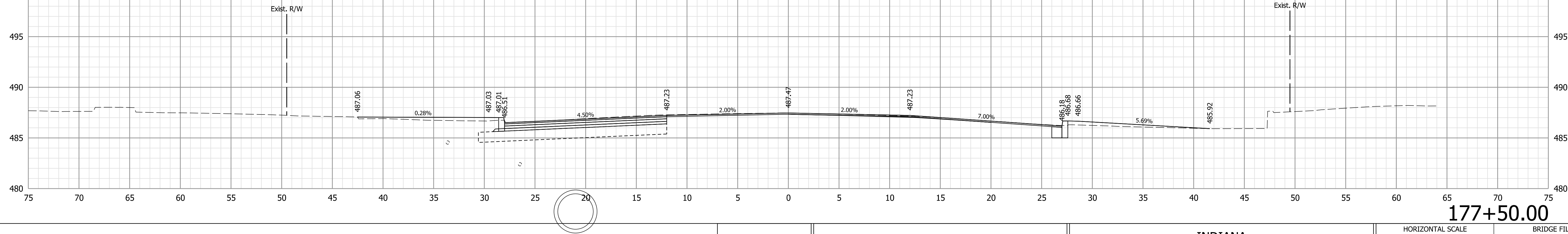

177+50.00

Note:  
 1. All utilities information shall be considered QL-D unless otherwise indicated and is for informational purposes only. The Contractor is responsible for locating and coordinating with utility companies in accordance with the plans and specifications.

**NOT FOR CONSTRUCTION**

RECOMMENDED FOR APPROVAL	DESIGN ENGINEER	6/9/2021	DATE
DESIGNED: WCM	6/9/2021	DRAWN: WCM	6/9/2021
CHECKED: LNB	6/9/2021	CHECKED: LNB	6/9/2021

INDIANA  
DEPARTMENT OF TRANSPORTATION

CROSS SECTIONS  
LINE "B"

HORIZONTAL SCALE	BRIDGE FILE
1" = 5'	N/A
VERTICAL SCALE	DESIGNATION
1" = 5'	1900334
SURVEY BOOK	SHEETS
Electronic	35 of 89
CONTRACT	PROJECT
R-42228	1900334

Plot: 6/9/2021 7:57:40 PM

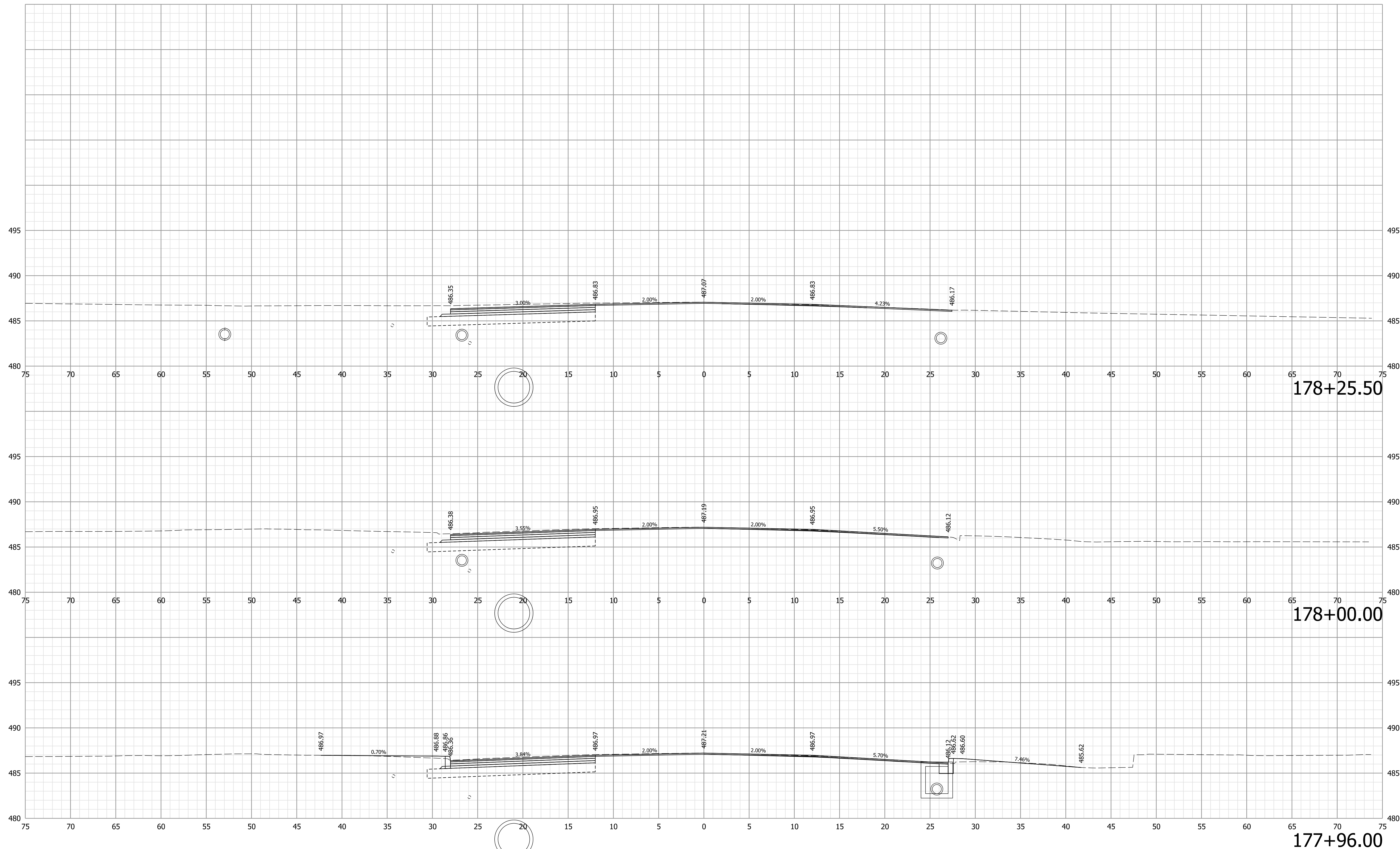

Note:  
 1. All utilities information shall be considered QL-D unless otherwise indicated and is for informational purposes only. The Contractor is responsible for locating and coordinating with utility companies in accordance with the plans and specifications.

**NOT FOR CONSTRUCTION**

RECOMMENDED FOR APPROVAL	DESIGN ENGINEER	6/9/2021	DATE
DESIGNED: WCM	6/9/2021	DRAWN: WCM	6/9/2021
CHECKED: LNB	6/9/2021	CHECKED: LNB	6/9/2021

INDIANA  
 DEPARTMENT OF TRANSPORTATION

CROSS SECTIONS  
 LINE "B"

HORIZONTAL SCALE	BRIDGE FILE
1" = 5'	N/A
VERTICAL SCALE	DESIGNATION
1" = 5'	1900334
SURVEY BOOK	SHEETS
Electronic	36 of 89
CONTRACT	PROJECT
R-42228	1900334

Plot: 6/9/2021 7:57:43 PM

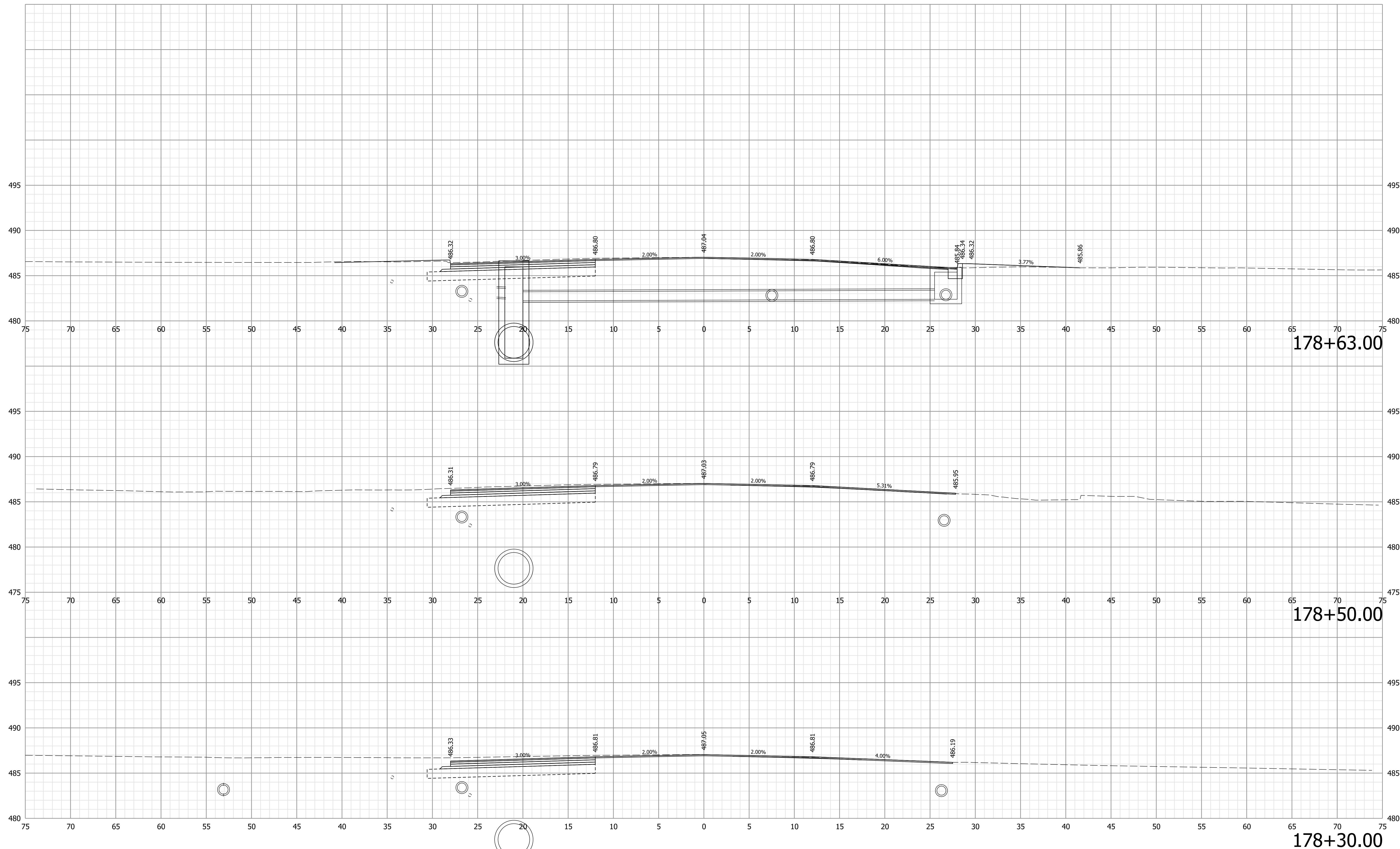

Note:  
 1. All utilities information shall be considered QL-D unless otherwise indicated and is for informational purposes only. The Contractor is responsible for locating and coordinating with utility companies in accordance with the plans and specifications.

**NOT FOR CONSTRUCTION**

RECOMMENDED FOR APPROVAL	DESIGN ENGINEER	6/9/2021	DATE
DESIGNED: WCM	6/9/2021	DRAWN: WCM	6/9/2021
CHECKED: LNB	6/9/2021	CHECKED: LNB	6/9/2021

INDIANA  
 DEPARTMENT OF TRANSPORTATION

CROSS SECTIONS  
 LINE "B"

HORIZONTAL SCALE	BRIDGE FILE
1" = 5'	N/A
VERTICAL SCALE	DESIGNATION
1" = 5'	1900334
SURVEY BOOK	SHEETS
Electronic	37 of 89
CONTRACT	PROJECT
R-42228	1900334

Plot: 6/9/2021 7:57:46 PM

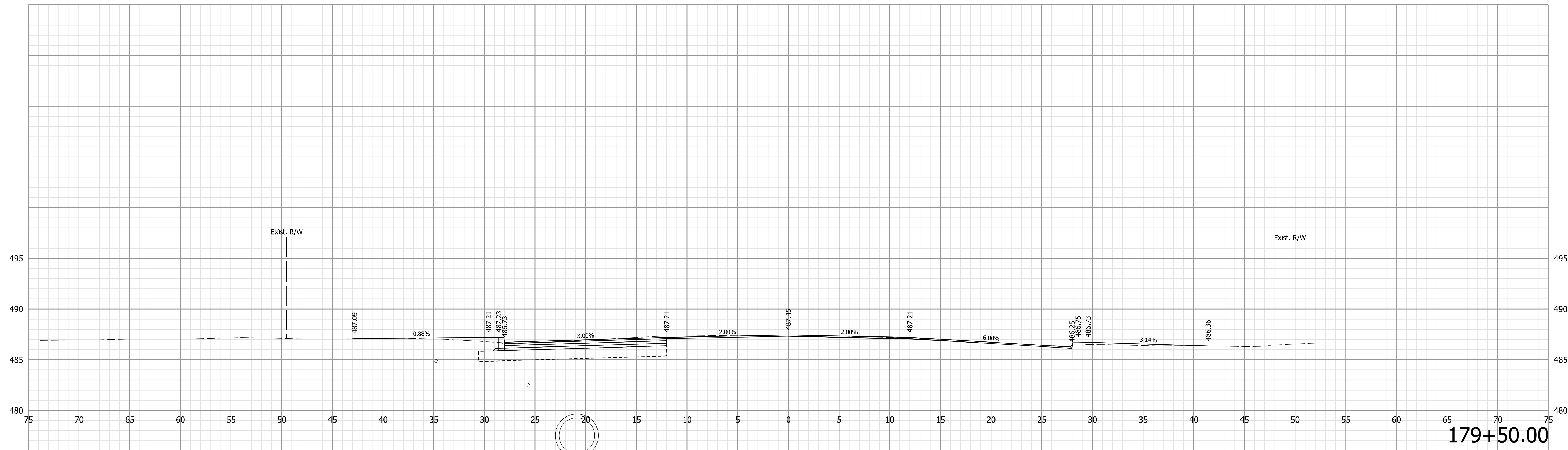

179+50.00

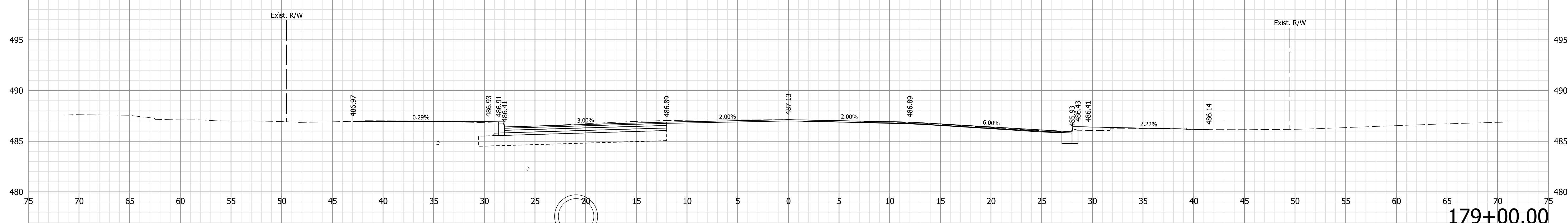

179+00.00

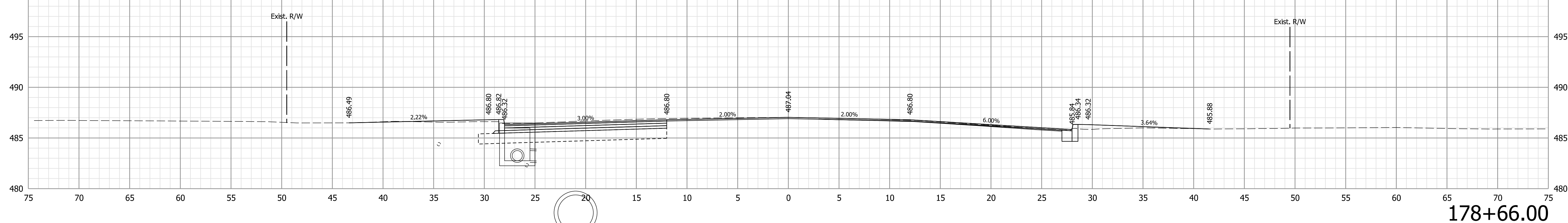

178+66.00

Note:  
 1. All utilities information shall be considered QL-D unless otherwise indicated and is for informational purposes only. The Contractor is responsible for locating and coordinating with utility companies in accordance with the plans and specifications.

NOT FOR CONSTRUCTION

RECOMMENDED FOR APPROVAL	DESIGN ENGINEER	6/9/2021	DATE
DESIGNED: WCM	6/9/2021	DRAWN: WCM	6/9/2021
CHECKED: LNB	6/9/2021	CHECKED: LNB	6/9/2021

INDIANA  
DEPARTMENT OF TRANSPORTATION

CROSS SECTIONS  
LINE "B"

HORIZONTAL SCALE	BRIDGE FILE
1" = 5'	N/A
VERTICAL SCALE	DESIGNATION
1" = 5'	1900334
SURVEY BOOK	SHEETS
Electronic	38 of 89
CONTRACT	PROJECT
R-42228	1900334

Plot: 6/9/2021 7:57:49 PM

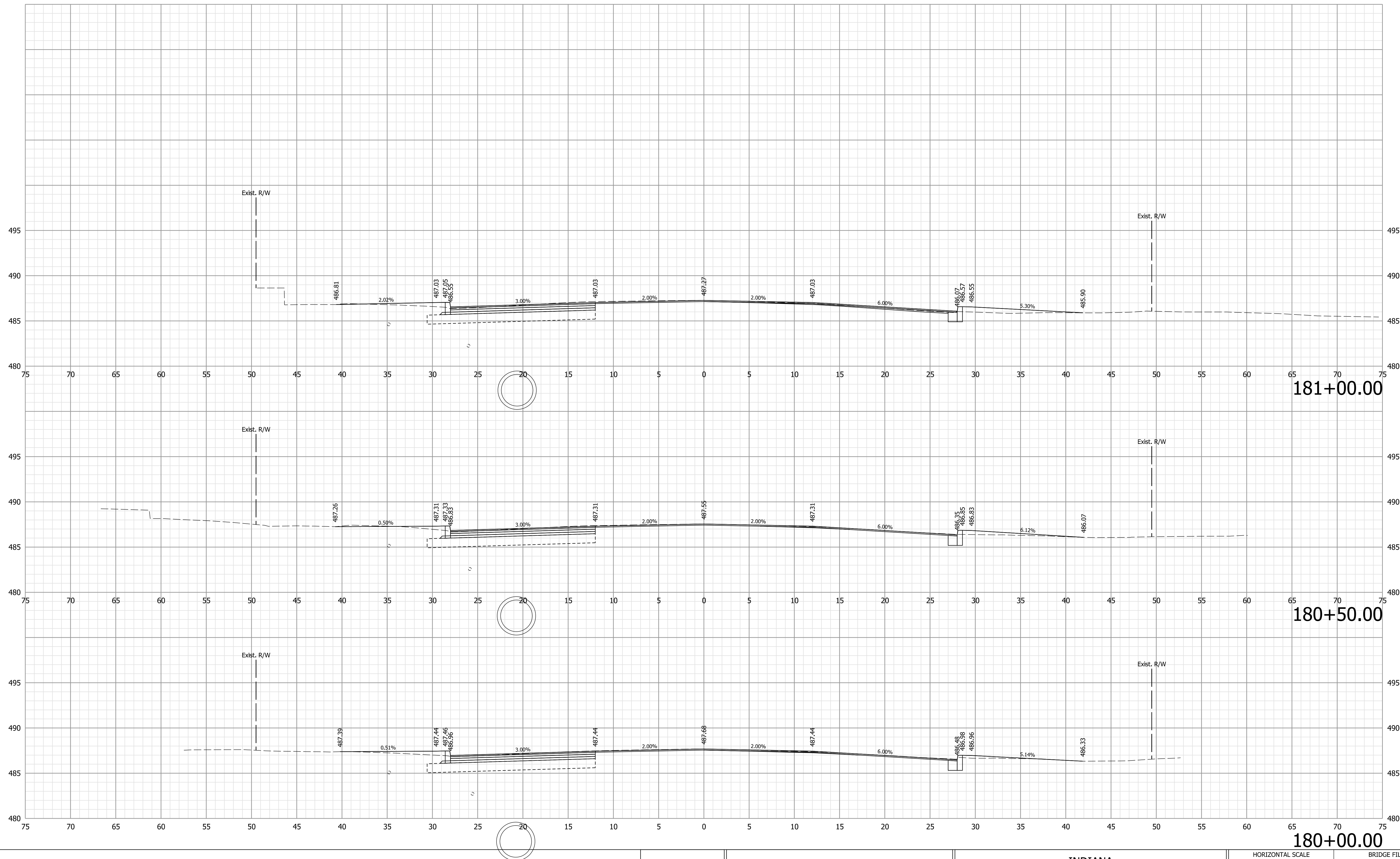

Note:  
 1. All utilities information shall be considered QL-D unless otherwise indicated and is for informational purposes only. The Contractor is responsible for locating and coordinating with utility companies in accordance with the plans and specifications.

**NOT FOR CONSTRUCTION**

RECOMMENDED FOR APPROVAL	DESIGN ENGINEER	6/9/2021	DATE
DESIGNED: WCM	6/9/2021	DRAWN: WCM	6/9/2021
CHECKED: LNB	6/9/2021	CHECKED: LNB	6/9/2021

INDIANA  
DEPARTMENT OF TRANSPORTATION

CROSS SECTIONS  
LINE "B"

HORIZONTAL SCALE	BRIDGE FILE
1" = 5'	N/A
VERTICAL SCALE	DESIGNATION
1" = 5'	1900334
SURVEY BOOK	SHEETS
Electronic	39 of 89
CONTRACT	PROJECT
R-42228	1900334

Plot: 6/9/2021 7:57:51 PM

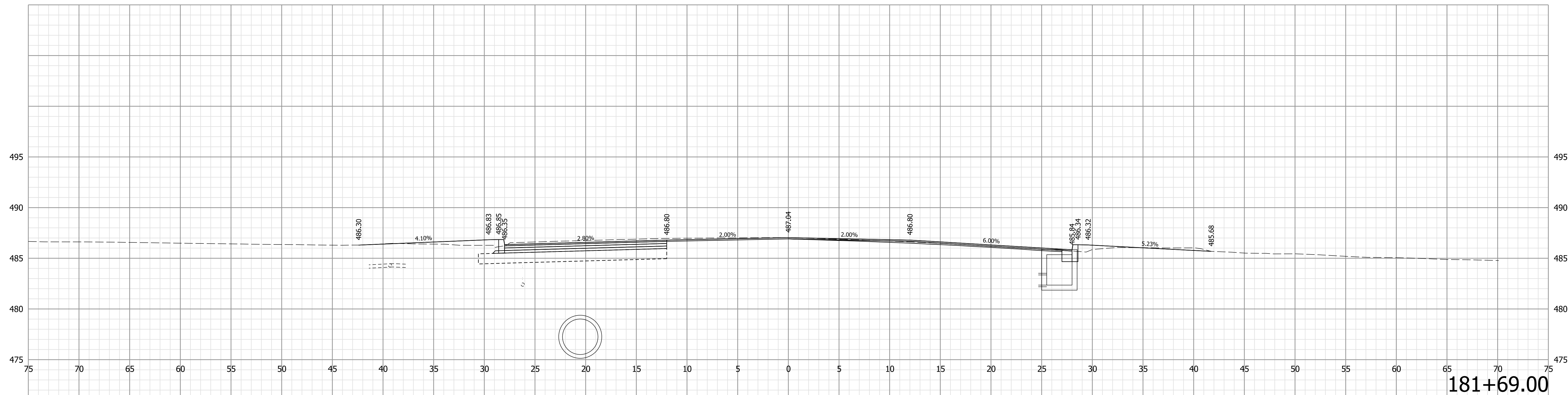

181+69.00

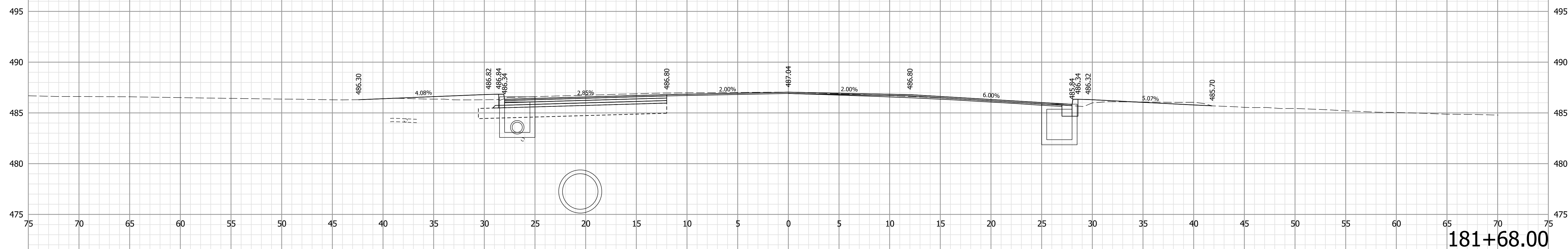

181+68.00

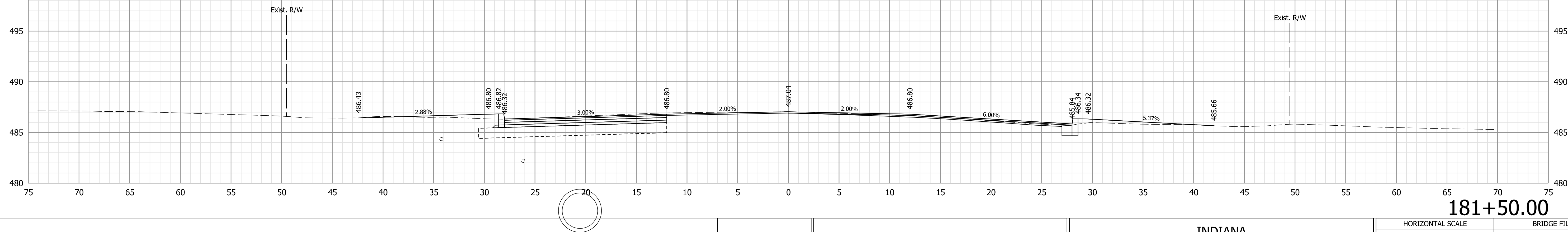

181+50.00

Note:  
1. All utilities information shall be considered QL-D unless otherwise indicated and is for informational purposes only. The Contractor is responsible for locating and coordinating with utility companies in accordance with the plans and specifications.

NOT FOR CONSTRUCTION

RECOMMENDED FOR APPROVAL	DESIGN ENGINEER	6/9/2021	DATE
DESIGNED: WCM	6/9/2021	DRAWN: WCM	6/9/2021
CHECKED: LNB	6/9/2021	CHECKED: LNB	6/9/2021

INDIANA  
DEPARTMENT OF TRANSPORTATION

CROSS SECTIONS  
LINE "B"

HORIZONTAL SCALE	BRIDGE FILE
1" = 5'	N/A
VERTICAL SCALE	DESIGNATION
1" = 5'	1900334
SURVEY BOOK	SHEETS
Electronic	40 of 89
CONTRACT	PROJECT
R-42228	1900334

Plot: 6/9/2021 7:57:54 PM



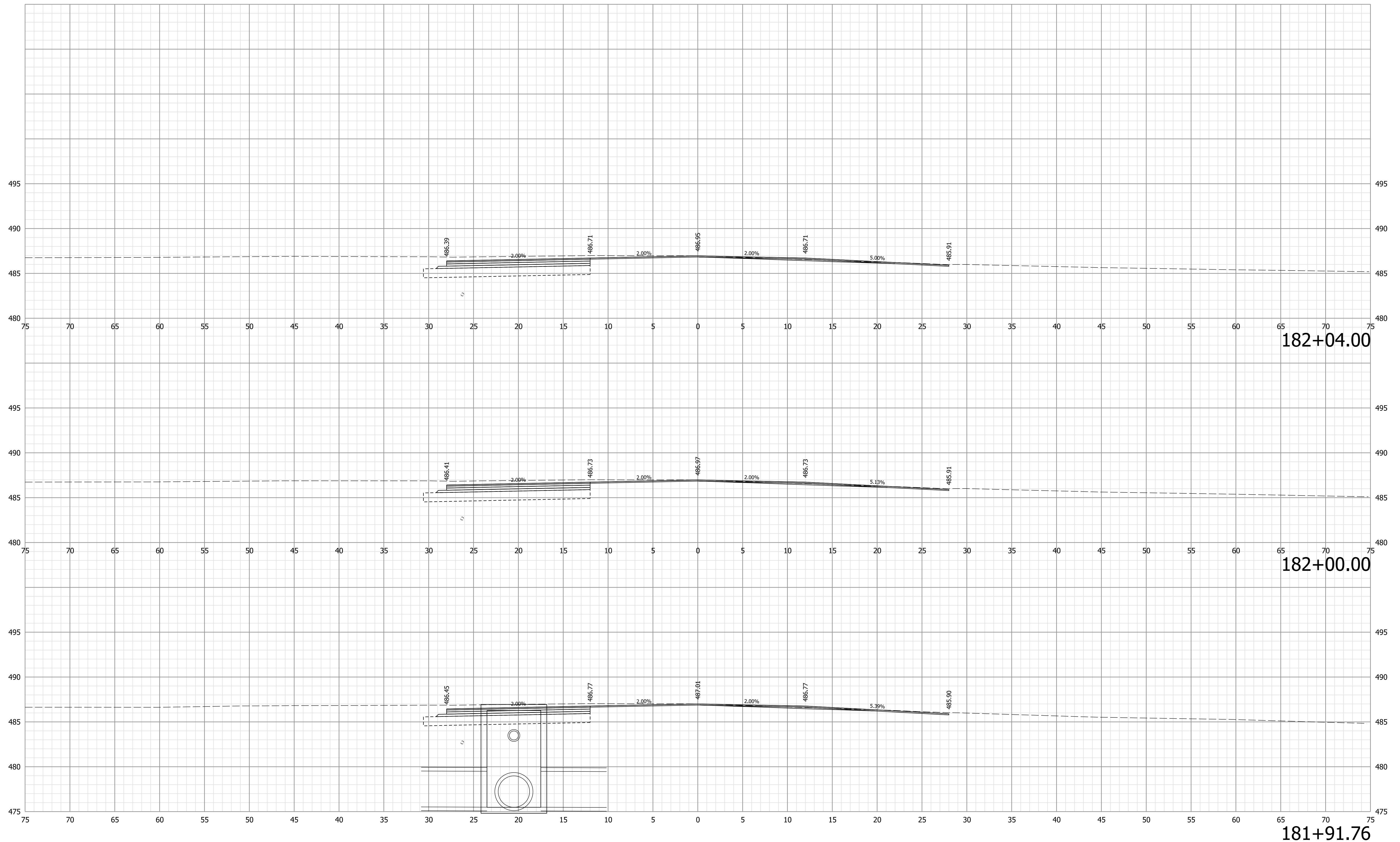

Note:  
 1. All utilities information shall be considered QL-D unless otherwise indicated and is for informational purposes only. The Contractor is responsible for locating and coordinating with utility companies in accordance with the plans and specifications.

**NOT FOR CONSTRUCTION**

RECOMMENDED FOR APPROVAL	DESIGN ENGINEER	6/9/2021	DATE
DESIGNED: WCM	6/9/2021	DRAWN: WCM	6/9/2021
CHECKED: LNB	6/9/2021	CHECKED: LNB	6/9/2021

INDIANA  
DEPARTMENT OF TRANSPORTATION

CROSS SECTIONS  
LINE "B"

HORIZONTAL SCALE	BRIDGE FILE
1" = 5'	N/A
VERTICAL SCALE	DESIGNATION
1" = 5'	1900334
SURVEY BOOK	SHEETS
Electronic	41 of 89
CONTRACT	PROJECT
R-42228	1900334

Plot: 6/9/2021 7:57:57 PM

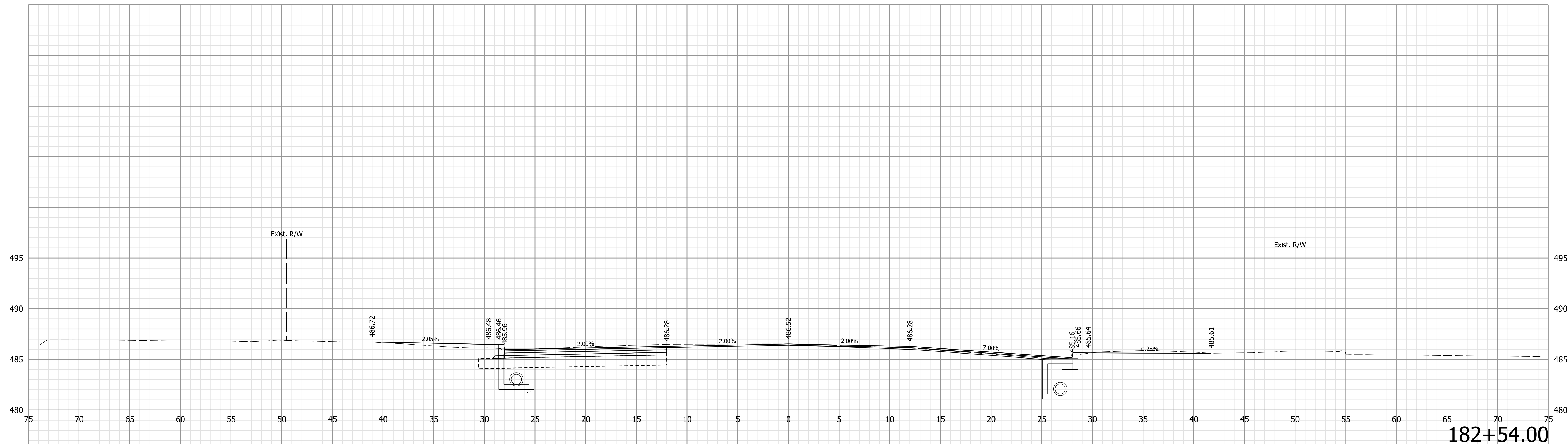

182+54.00

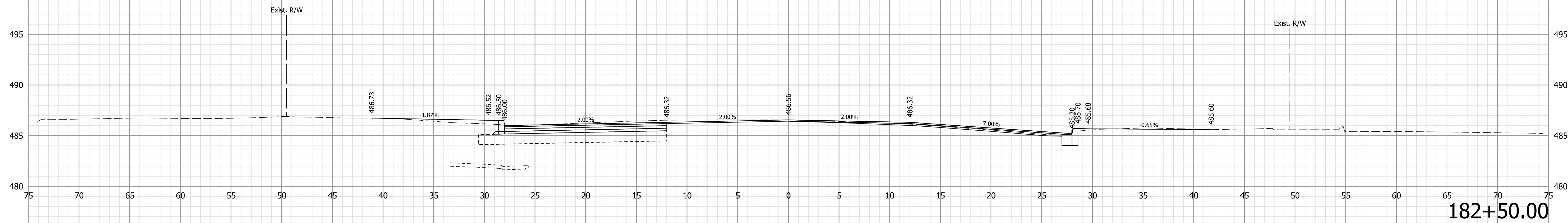

182+50.00

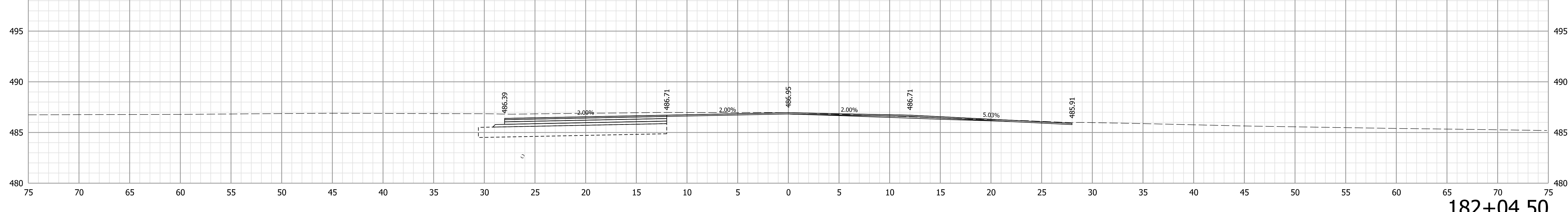

182+04.50

Note:  
 1. All utilities information shall be considered QL-D unless otherwise indicated and is for informational purposes only. The Contractor is responsible for locating and coordinating with utility companies in accordance with the plans and specifications.

NOT FOR CONSTRUCTION

RECOMMENDED FOR APPROVAL	DESIGN ENGINEER	6/9/2021	DATE
DESIGNED: WCM	6/9/2021	DRAWN: WCM	6/9/2021
CHECKED: LNB	6/9/2021	CHECKED: LNB	6/9/2021

INDIANA  
DEPARTMENT OF TRANSPORTATION

CROSS SECTIONS  
LINE "B"

HORIZONTAL SCALE	BRIDGE FILE
1" = 5'	N/A
VERTICAL SCALE	DESIGNATION
1" = 5'	1900334
SURVEY BOOK	SHEETS
Electronic	42 of 89
CONTRACT	PROJECT
R-42228	1900334

Plot: 6/9/2021 7:58:00 PM

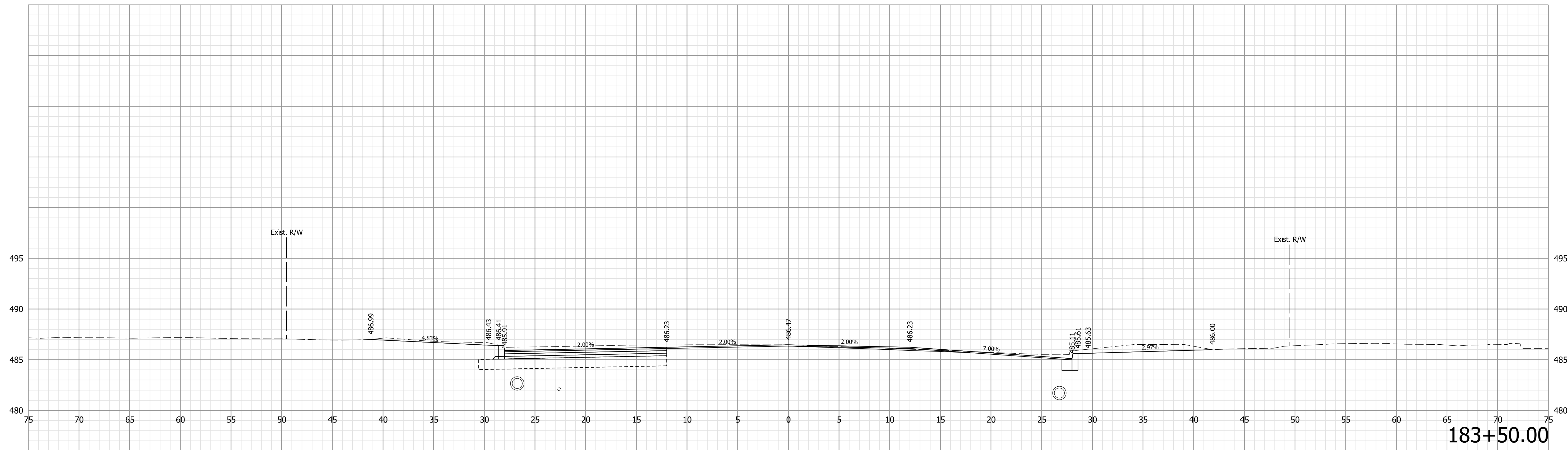

183+50.00

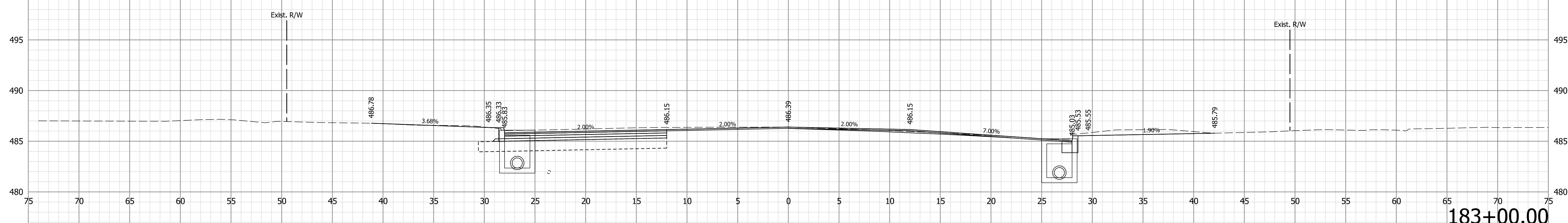

183+00.00

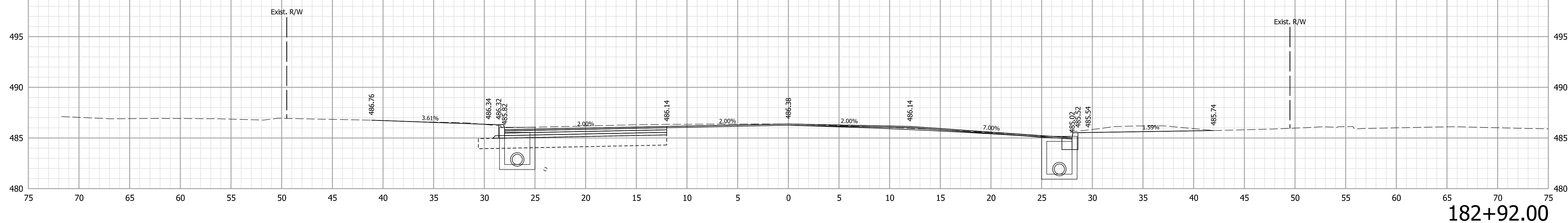

182+92.00

Note:  
1. All utilities information shall be considered QL-D unless otherwise indicated and is for informational purposes only. The Contractor is responsible for locating and coordinating with utility companies in accordance with the plans and specifications.

**NOT FOR CONSTRUCTION**

RECOMMENDED FOR APPROVAL	DESIGN ENGINEER	6/9/2021	DATE
DESIGNED: WCM	6/9/2021	DRAWN: WCM	6/9/2021
CHECKED: LNB	6/9/2021	CHECKED: LNB	6/9/2021

INDIANA  
DEPARTMENT OF TRANSPORTATION

CROSS SECTIONS  
LINE "B"

HORIZONTAL SCALE	BRIDGE FILE
1" = 5'	N/A
VERTICAL SCALE	DESIGNATION
1" = 5'	1900334
SURVEY BOOK	SHEETS
Electronic	43 of 89
CONTRACT	PROJECT
R-42228	1900334

Pct: 6/9/2021 7:58:03 PM

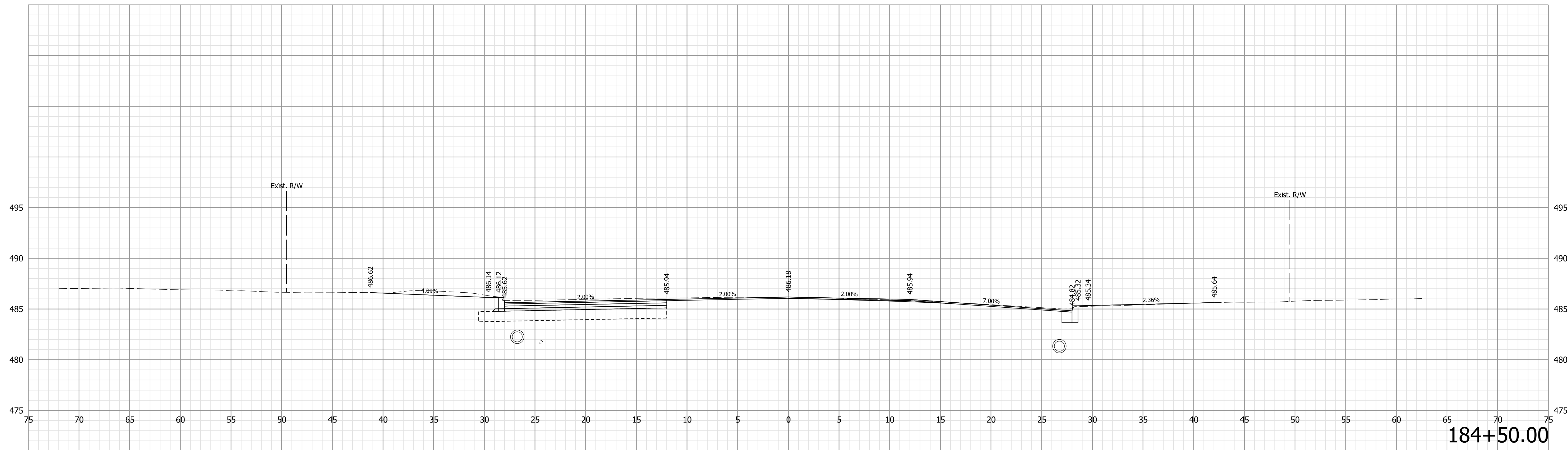

184+50.00

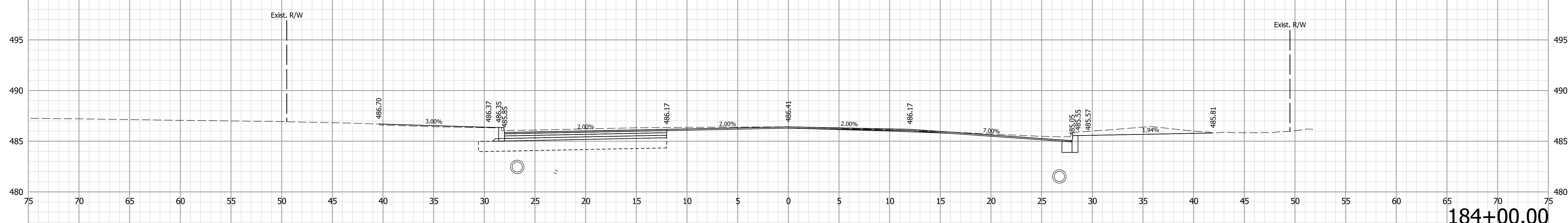

184+00.00

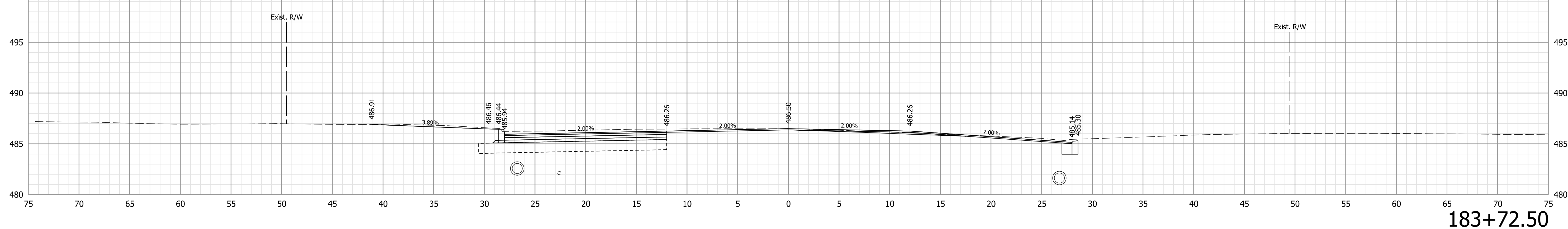

183+72.50

Note:  
 1. All utilities information shall be considered QL-D unless otherwise indicated and is for informational purposes only. The Contractor is responsible for locating and coordinating with utility companies in accordance with the plans and specifications.

**NOT FOR CONSTRUCTION**

RECOMMENDED FOR APPROVAL	DESIGN ENGINEER	6/9/2021	DATE
DESIGNED: WCM	6/9/2021	DRAWN: WCM	6/9/2021
CHECKED: LNB	6/9/2021	CHECKED: LNB	6/9/2021

INDIANA  
 DEPARTMENT OF TRANSPORTATION  
  
 CROSS SECTIONS  
 LINE "B"

HORIZONTAL SCALE	BRIDGE FILE
1" = 5'	N/A
VERTICAL SCALE	DESIGNATION
1" = 5'	1900334
SURVEY BOOK	SHEETS
Electronic	44 of 89
CONTRACT	PROJECT
R-42228	1900334

Plot: 6/9/2021 7:58:06 PM

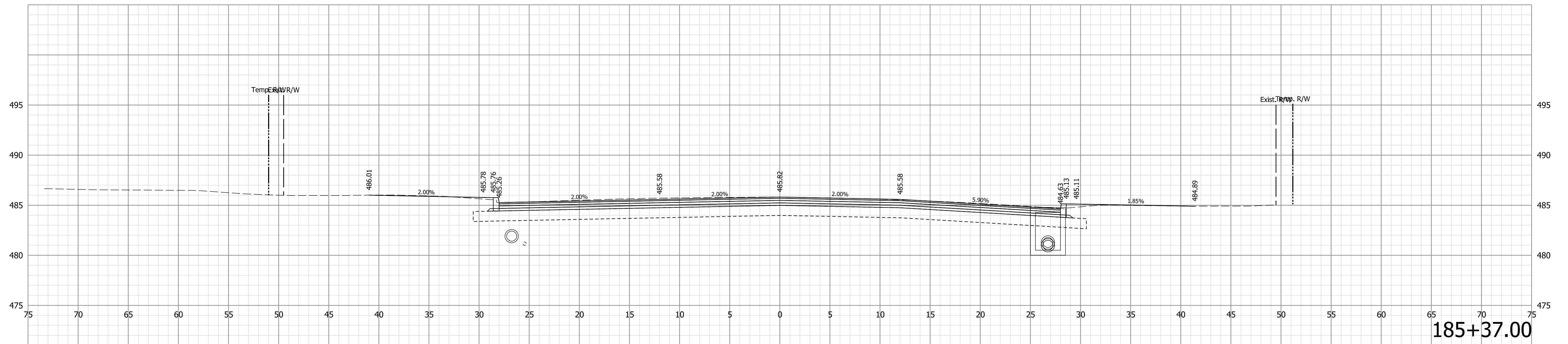

185+37.00

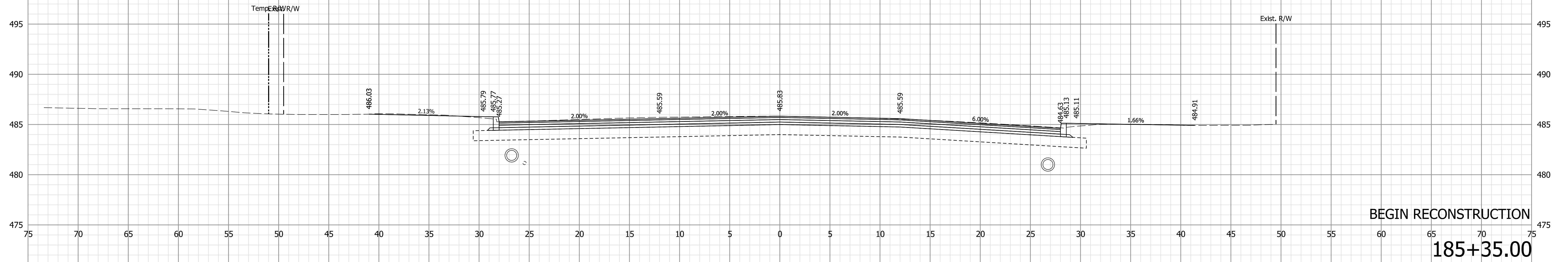

BEGIN RECONSTRUCTION  
185+35.00

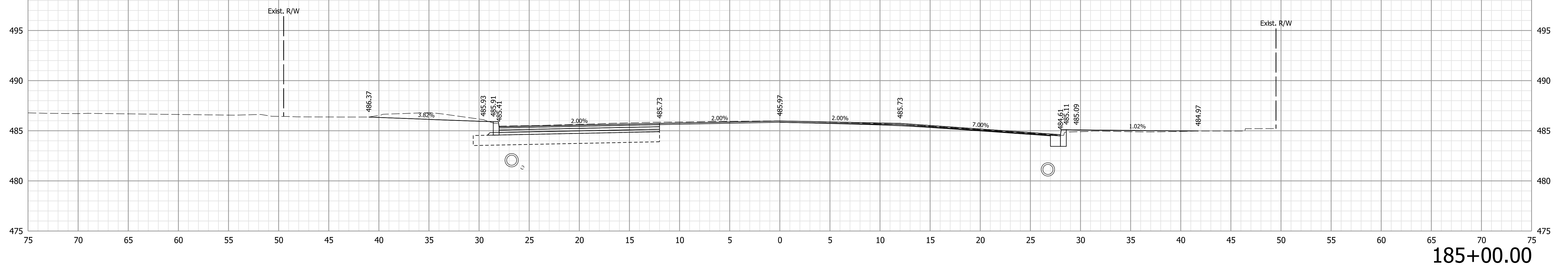

185+00.00

Note:  
1. All utilities information shall be considered QL-D unless otherwise indicated and is for informational purposes only. The Contractor is responsible for locating and coordinating with utility companies in accordance with the plans and specifications.

NOT FOR CONSTRUCTION

RECOMMENDED FOR APPROVAL	DESIGN ENGINEER	6/9/2021	DATE
DESIGNED: WCM	6/9/2021	DRAWN: WCM	6/9/2021
CHECKED: LNB	6/9/2021	CHECKED: LNB	6/9/2021

INDIANA  
DEPARTMENT OF TRANSPORTATION

CROSS SECTIONS  
LINE "B"

HORIZONTAL SCALE	BRIDGE FILE
1" = 5'	N/A
VERTICAL SCALE	DESIGNATION
1" = 5'	1900334
SURVEY BOOK	SHEETS
Electronic	45 of 89
CONTRACT	PROJECT
R-42228	1900334

Plot: 6/9/2021 7:58:08 PM

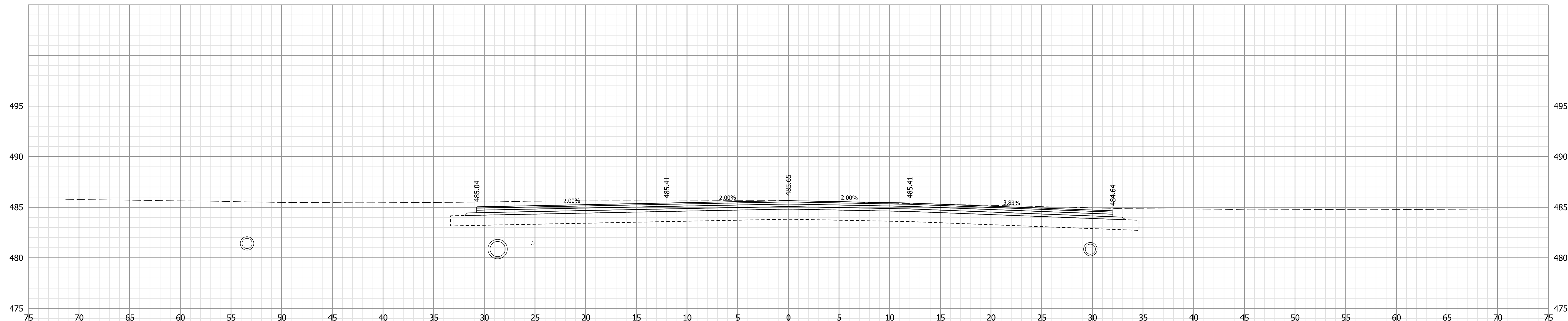

185+78.50

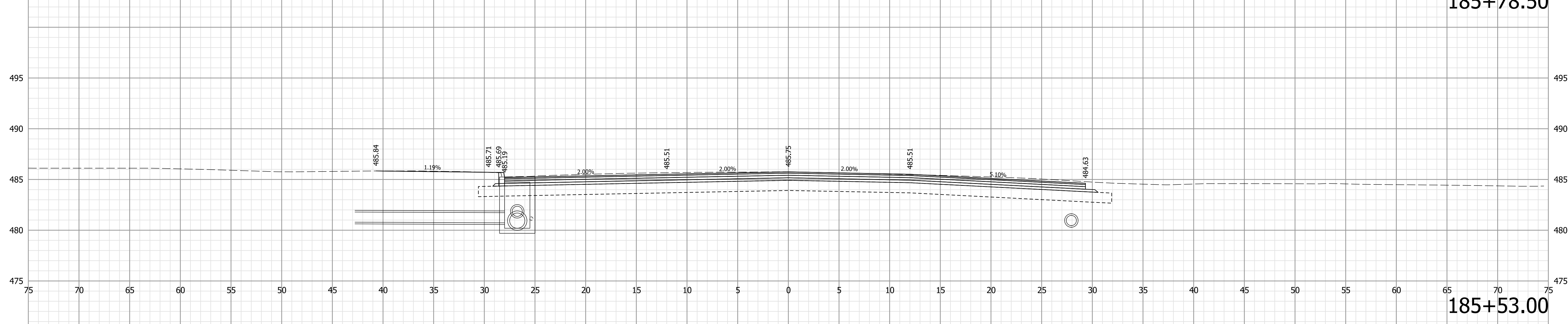

185+53.00

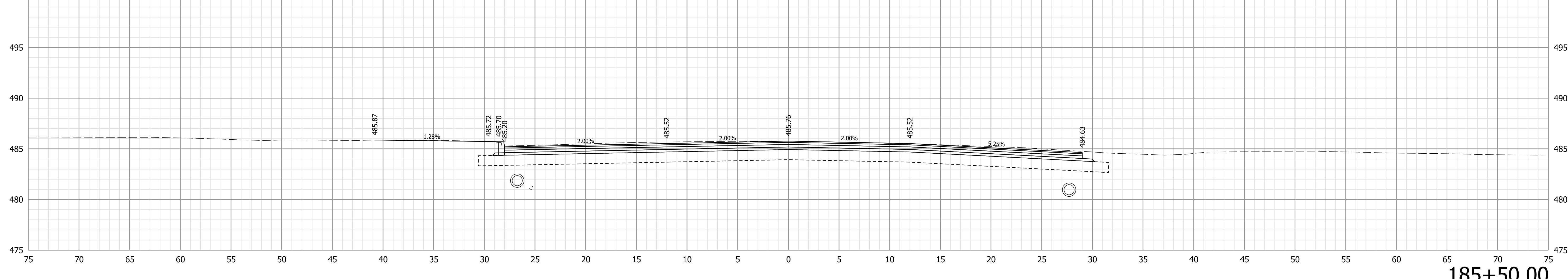

185+50.00

Note:  
 1. All utilities information shall be considered QL-D unless otherwise indicated and is for informational purposes only. The Contractor is responsible for locating and coordinating with utility companies in accordance with the plans and specifications.

**NOT FOR CONSTRUCTION**

RECOMMENDED FOR APPROVAL	DESIGN ENGINEER	6/9/2021	DATE
DESIGNED: WCM	6/9/2021	DRAWN: WCM	6/9/2021
CHECKED: LNB	6/9/2021	CHECKED: LNB	6/9/2021

INDIANA  
DEPARTMENT OF TRANSPORTATION

CROSS SECTIONS  
LINE "B"

HORIZONTAL SCALE	BRIDGE FILE
1" = 5'	N/A
VERTICAL SCALE	DESIGNATION
1" = 5'	1900334
SURVEY BOOK	SHEETS
Electronic	46 of 89
CONTRACT	PROJECT
R-42228	1900334

Plot: 6/9/2021 7:58:11 PM

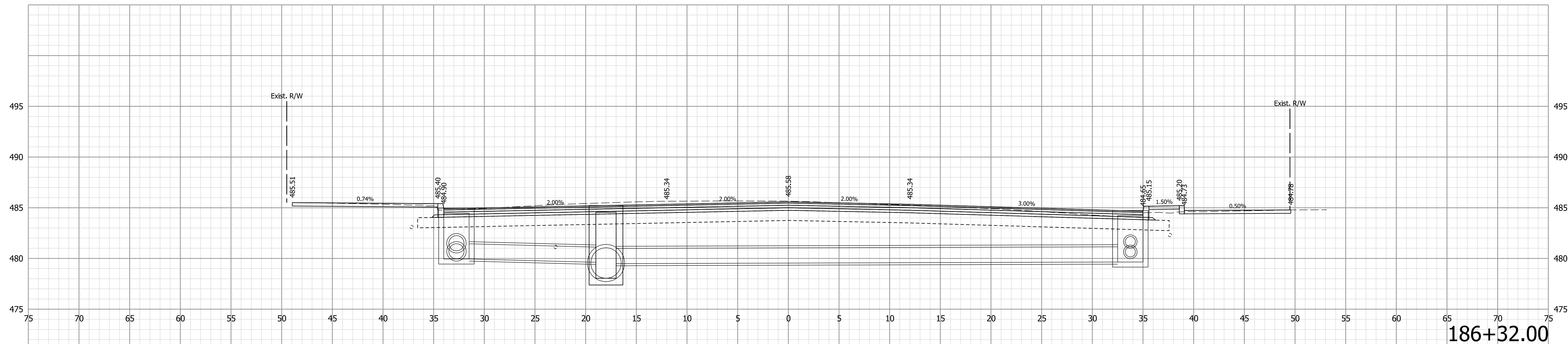

186+32.00

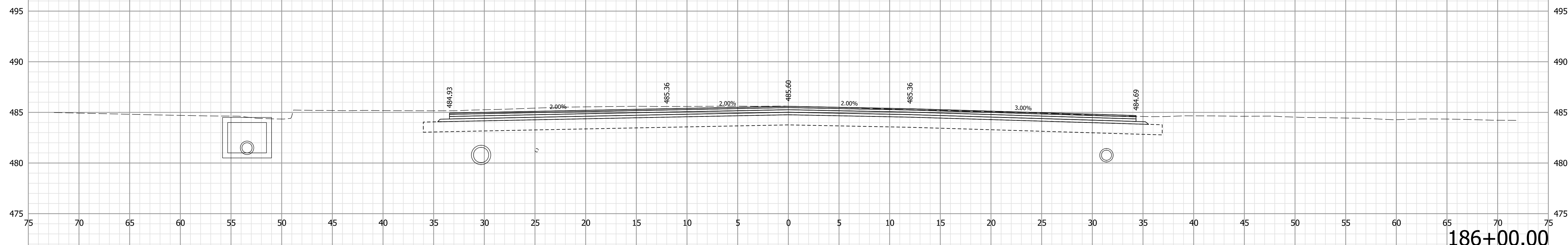

186+00.00

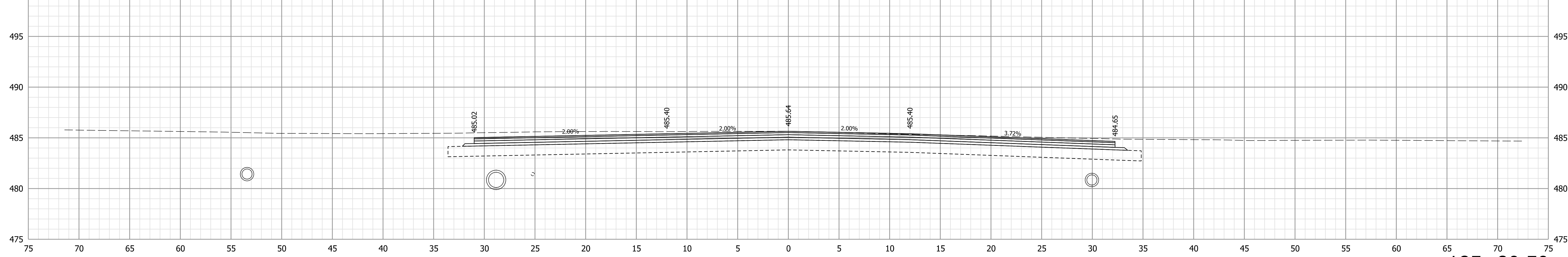

185+80.50

Note:

- All utilities information shall be considered QL-D unless otherwise indicated and is for informational purposes only. The Contractor is responsible for locating and coordinating with utility companies in accordance with the plans and specifications.

**NOT FOR CONSTRUCTION**

RECOMMENDED FOR APPROVAL	DESIGN ENGINEER	6/9/2021	DATE
DESIGNED: WCM	6/9/2021	DRAWN: WCM	6/9/2021
CHECKED: LNB	6/9/2021	CHECKED: LNB	6/9/2021

INDIANA  
DEPARTMENT OF TRANSPORTATION

CROSS SECTIONS  
LINE "B"

HORIZONTAL SCALE	BRIDGE FILE
1" = 5'	N/A
VERTICAL SCALE	DESIGNATION
1" = 5'	1900334
SURVEY BOOK	SHEETS
Electronic	47 of 89
CONTRACT	PROJECT
R-42228	1900334

Plot: 6/9/2021 7:58:14 PM

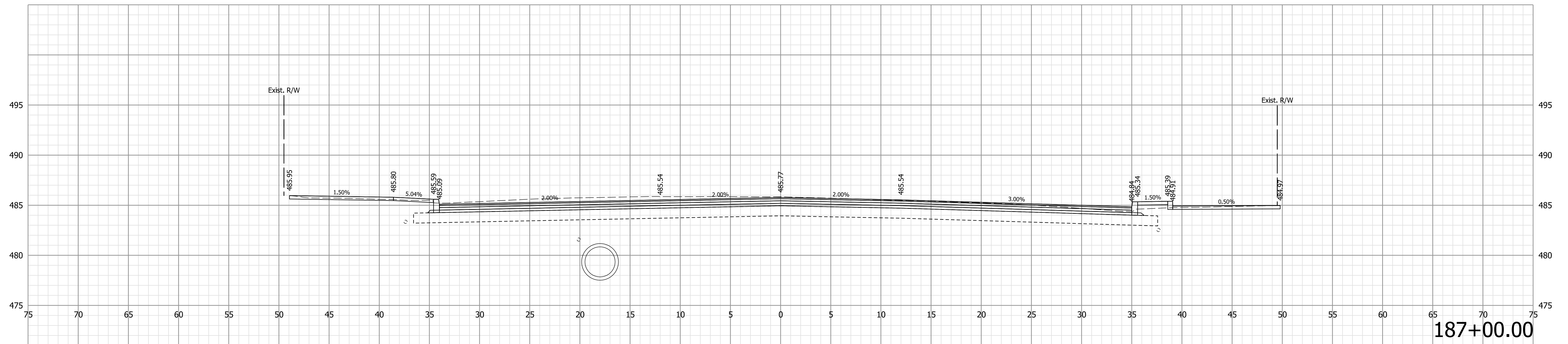

187+00.00

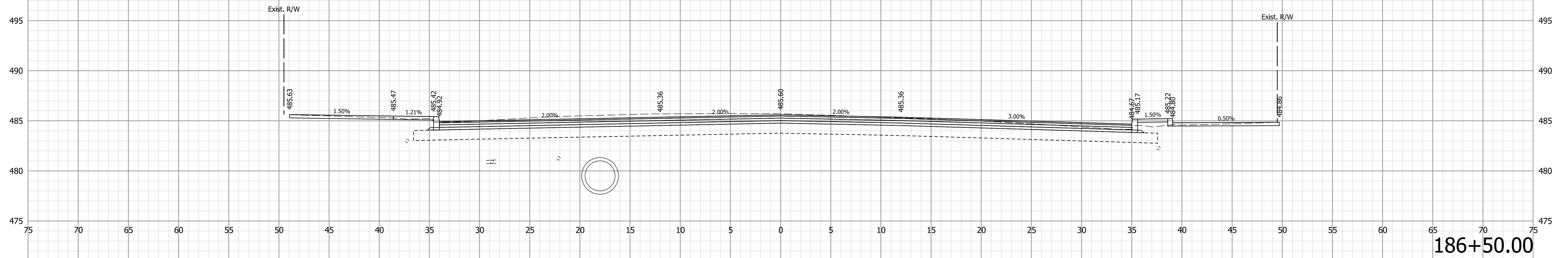

186+50.00

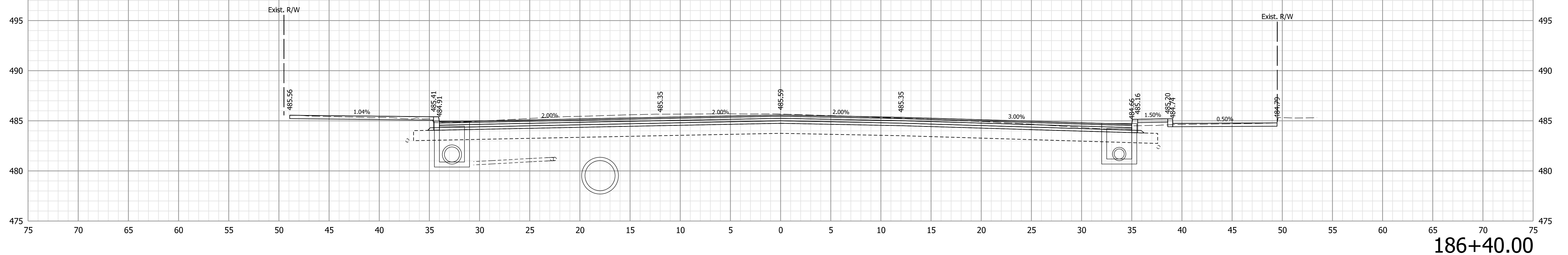

186+40.00

Note:  
 1. All utilities information shall be considered QL-D unless otherwise indicated and is for informational purposes only. The Contractor is responsible for locating and coordinating with utility companies in accordance with the plans and specifications.

**NOT FOR CONSTRUCTION**

RECOMMENDED FOR APPROVAL	DESIGN ENGINEER	6/9/2021	DATE
DESIGNED: WCM	6/9/2021	DRAWN: WCM	6/9/2021
CHECKED: LNB	6/9/2021	CHECKED: LNB	6/9/2021

INDIANA  
DEPARTMENT OF TRANSPORTATION

CROSS SECTIONS  
LINE "B"

HORIZONTAL SCALE	BRIDGE FILE
1" = 5'	N/A
VERTICAL SCALE	DESIGNATION
1" = 5'	1900334
SURVEY BOOK	SHEETS
Electronic	48 of 89
CONTRACT	PROJECT
R-42228	1900334

Plot: 6/9/2021 7:58:17 PM



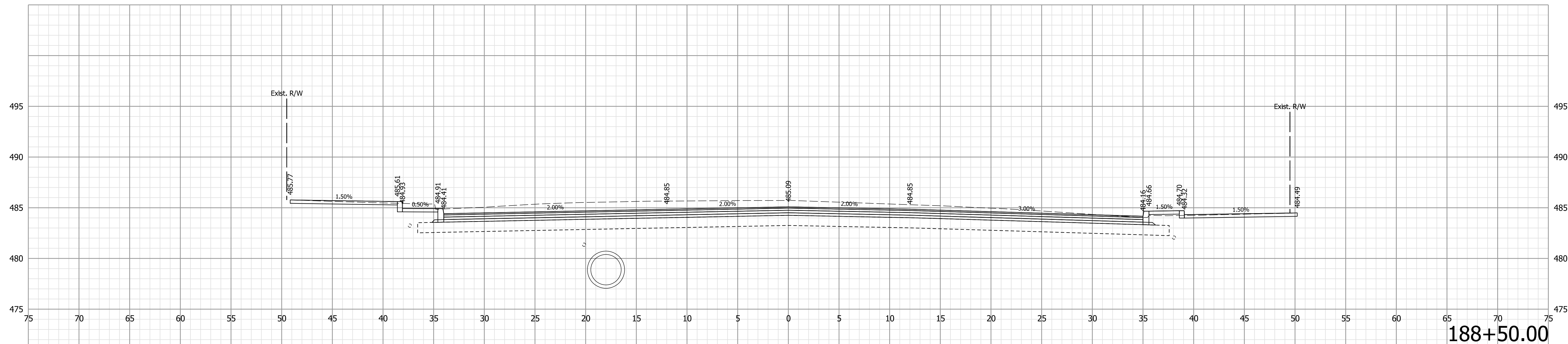

188+50.00

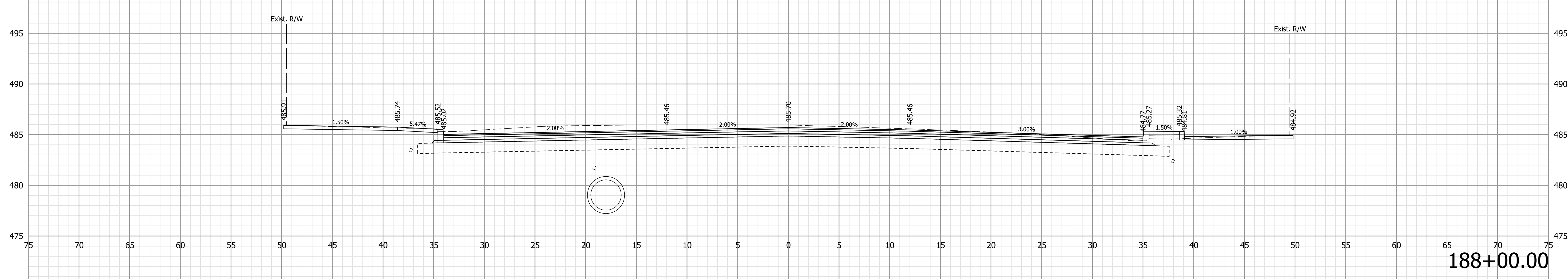

188+00.00

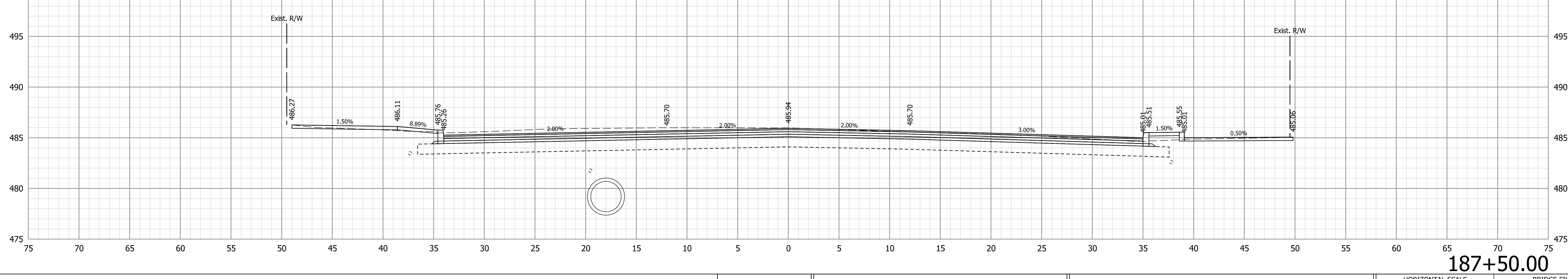

187+50.00

Note:  
 1. All utilities information shall be considered QL-D unless otherwise indicated and is for informational purposes only. The Contractor is responsible for locating and coordinating with utility companies in accordance with the plans and specifications.

**NOT FOR CONSTRUCTION**

RECOMMENDED FOR APPROVAL	DESIGN ENGINEER	6/9/2021	DATE
DESIGNED: WCM	6/9/2021	DRAWN: WCM	6/9/2021
CHECKED: LNB	6/9/2021	CHECKED: LNB	6/9/2021

INDIANA  
 DEPARTMENT OF TRANSPORTATION

CROSS SECTIONS  
 LINE "B"

HORIZONTAL SCALE	BRIDGE FILE
1" = 5'	N/A
VERTICAL SCALE	DESIGNATION
1" = 5'	1900334
SURVEY BOOK	SHEETS
Electronic	49 of 89
CONTRACT	PROJECT
R-42228	1900334

Plot: 6/9/2021 7:58:20 PM

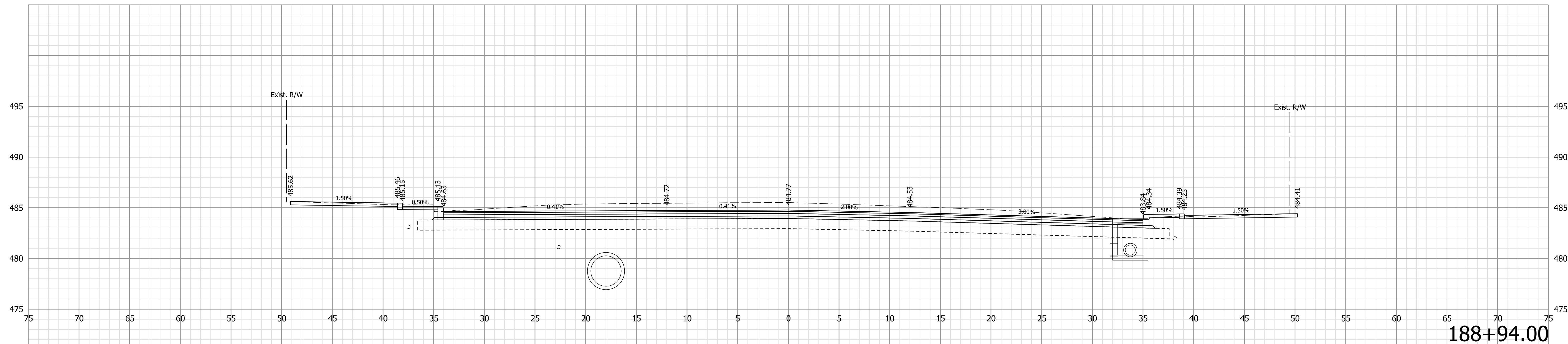

188+94.00

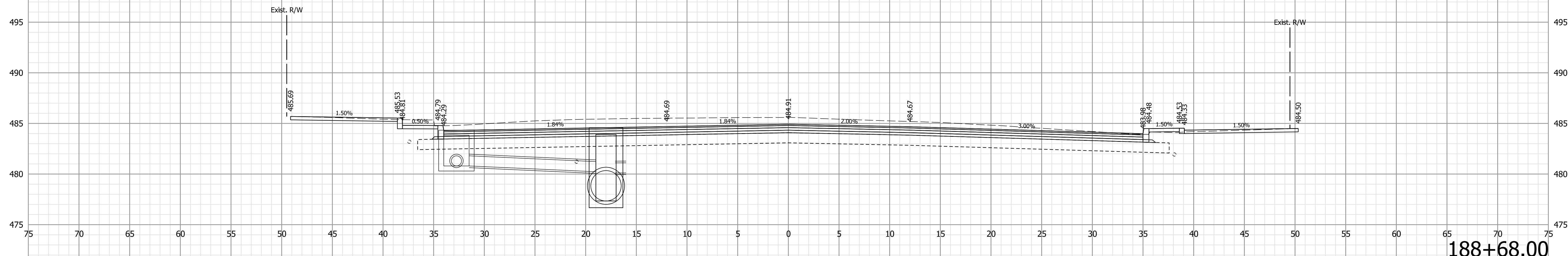

188+68.00

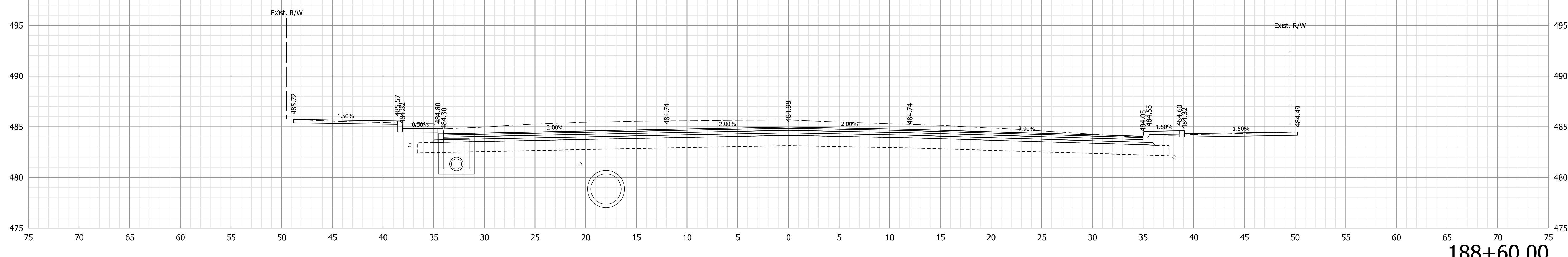

188+60.00

Note:

- All utilities information shall be considered QL-D unless otherwise indicated and is for informational purposes only. The Contractor is responsible for locating and coordinating with utility companies in accordance with the plans and specifications.

NOT FOR CONSTRUCTION

RECOMMENDED FOR APPROVAL	DESIGN ENGINEER	6/9/2021	DATE
DESIGNED: WCM	6/9/2021	DRAWN: WCM	6/9/2021
CHECKED: LNB	6/9/2021	CHECKED: LNB	6/9/2021

INDIANA  
DEPARTMENT OF TRANSPORTATION

CROSS SECTIONS  
LINE "B"

HORIZONTAL SCALE	BRIDGE FILE
1" = 5'	N/A
VERTICAL SCALE	DESIGNATION
1" = 5'	1900334
SURVEY BOOK	SHEETS
Electronic	50 of 89
CONTRACT	PROJECT
R-42228	1900334

Pct: 6/9/2021 7:58:22 PM

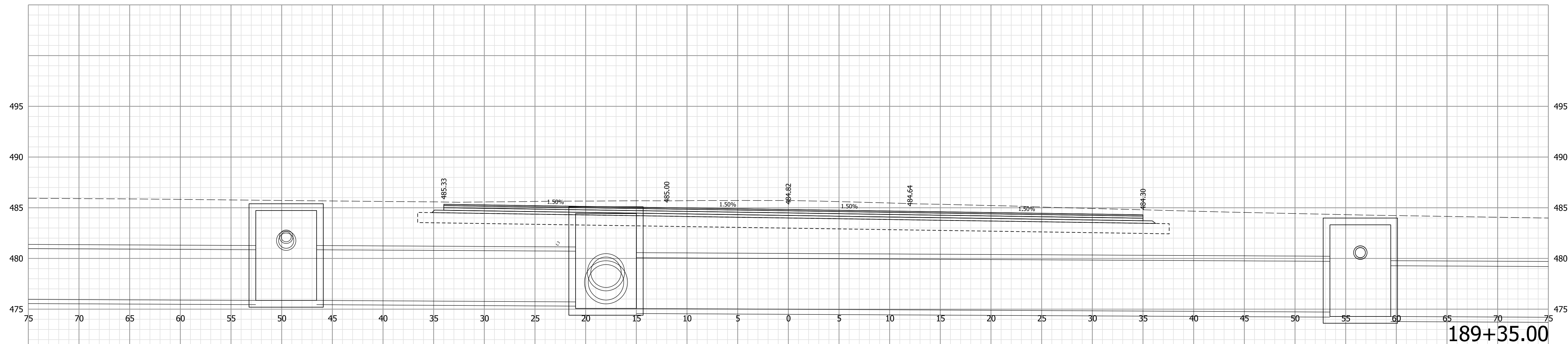

189+35.00

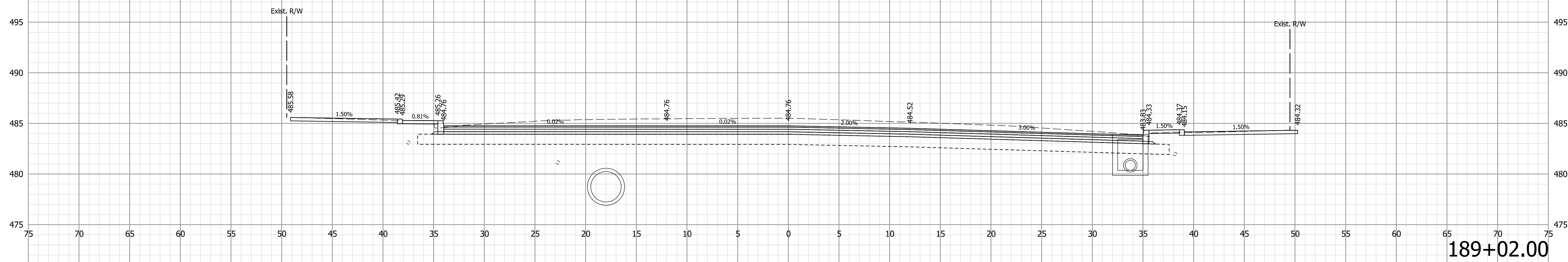

189+02.00

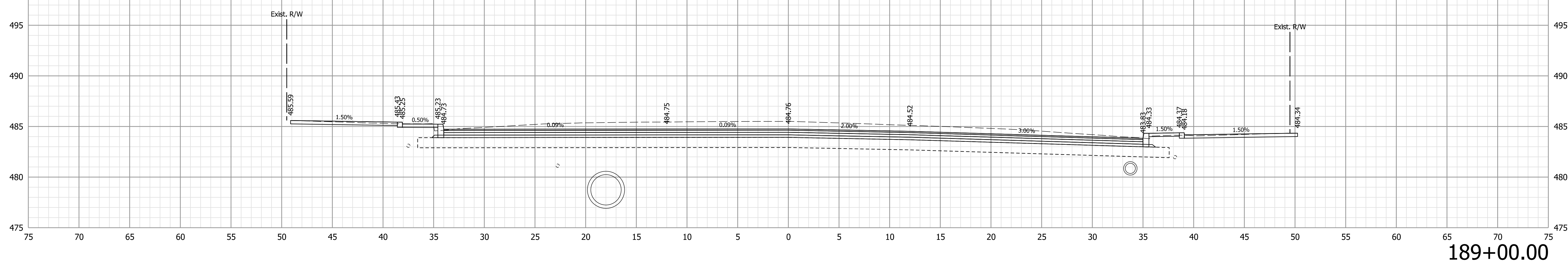

189+00.00

Note:

- All utilities information shall be considered QL-D unless otherwise indicated and is for informational purposes only. The Contractor is responsible for locating and coordinating with utility companies in accordance with the plans and specifications.

**NOT FOR CONSTRUCTION**

RECOMMENDED FOR APPROVAL	DESIGN ENGINEER	6/9/2021	DATE
DESIGNED: WCM	6/9/2021	DRAWN: WCM	6/9/2021
CHECKED: LNB	6/9/2021	CHECKED: LNB	6/9/2021

INDIANA  
DEPARTMENT OF TRANSPORTATION

CROSS SECTIONS  
LINE "B"

HORIZONTAL SCALE	BRIDGE FILE
1" = 5'	N/A
VERTICAL SCALE	DESIGNATION
1" = 5'	1900334
SURVEY BOOK	SHEETS
Electronic	51 of 89
CONTRACT	PROJECT
R-42228	1900334

Plot: 6/9/2021 7:58:25 PM

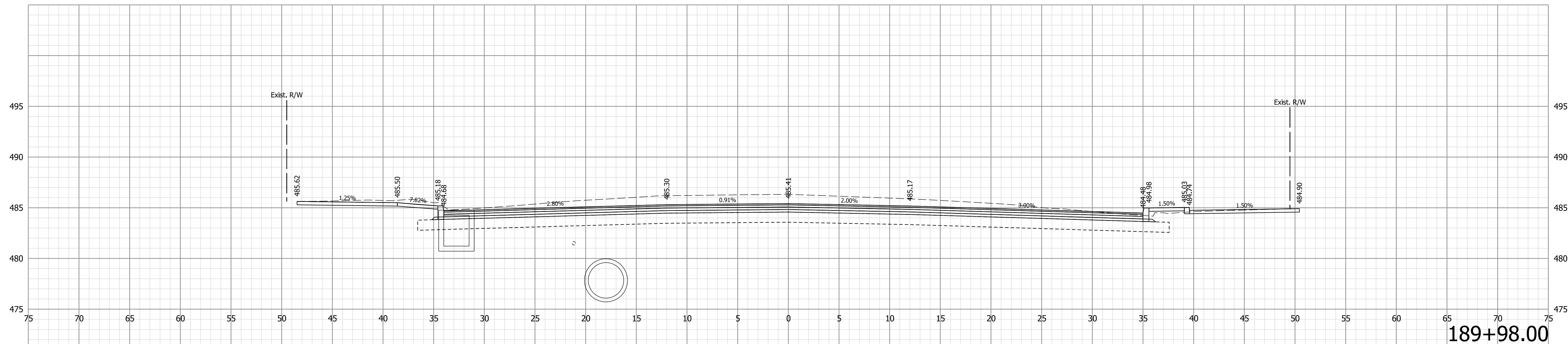

189+98.00

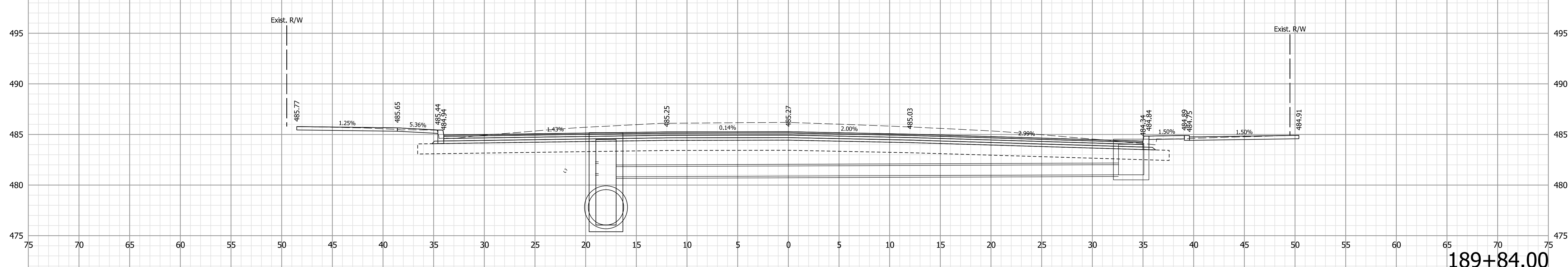

189+84.00

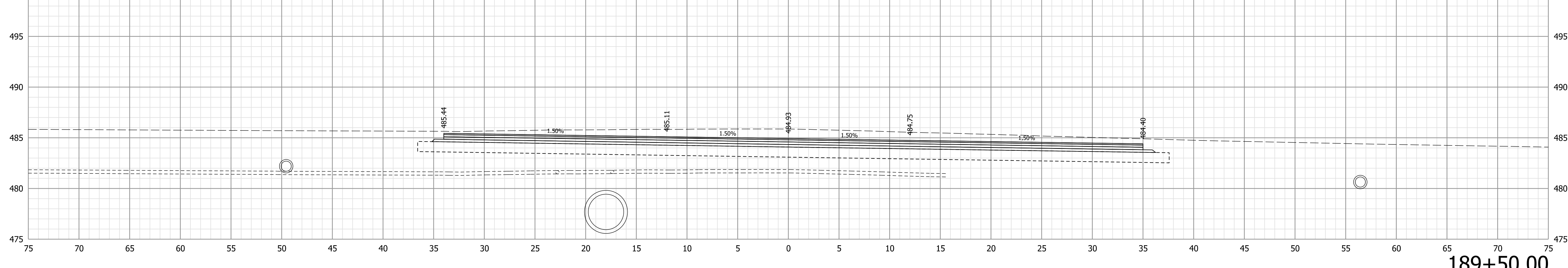

189+50.00

Note:  
1. All utilities information shall be considered QL-D unless otherwise indicated and is for informational purposes only. The Contractor is responsible for locating and coordinating with utility companies in accordance with the plans and specifications.

**NOT FOR CONSTRUCTION**

RECOMMENDED FOR APPROVAL	DESIGN ENGINEER	6/9/2021	DATE
DESIGNED: WCM	6/9/2021	DRAWN: WCM	6/9/2021
CHECKED: LNB	6/9/2021	CHECKED: LNB	6/9/2021

INDIANA  
DEPARTMENT OF TRANSPORTATION

CROSS SECTIONS  
LINE "B"

HORIZONTAL SCALE	BRIDGE FILE
1" = 5'	N/A
VERTICAL SCALE	DESIGNATION
1" = 5'	1900334
SURVEY BOOK	SHEETS
Electronic	52 of 89
CONTRACT	PROJECT
R-42228	1900334

Plot: 6/9/2021 7:58:28 PM

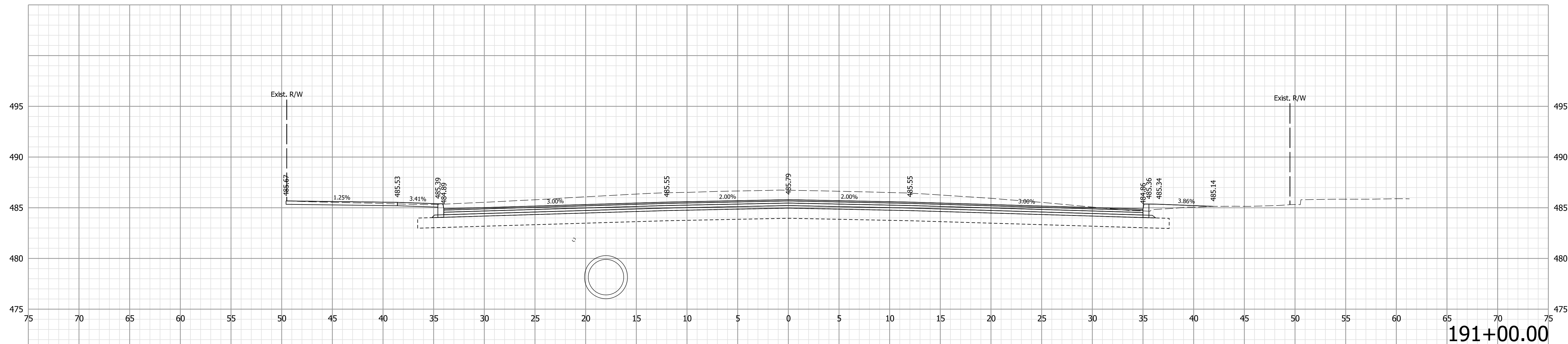

191+00.00

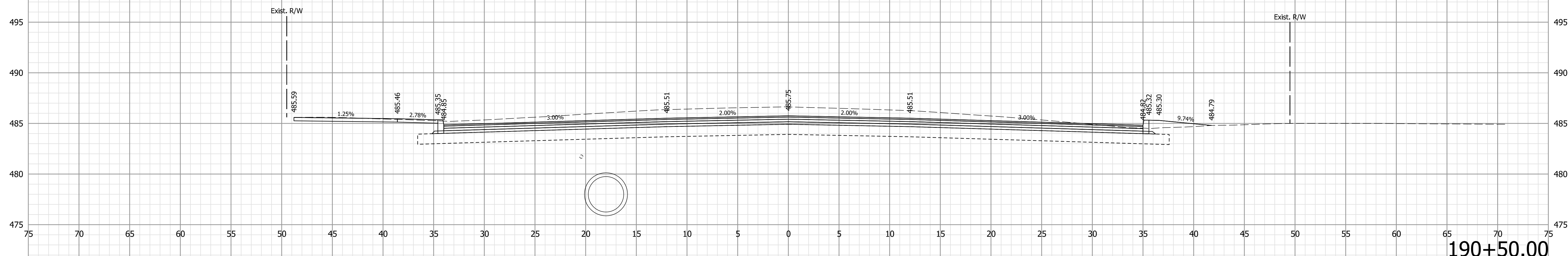

190+50.00

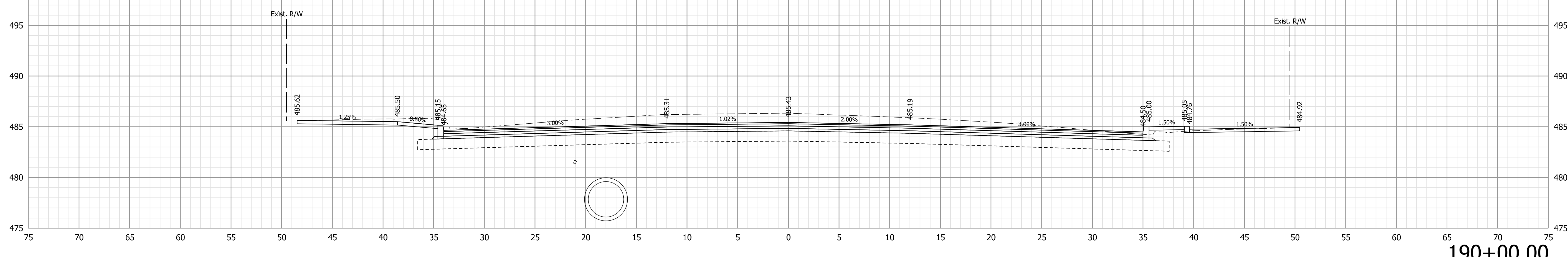

190+00.00

Note:

- All utilities information shall be considered QL-D unless otherwise indicated and is for informational purposes only. The Contractor is responsible for locating and coordinating with utility companies in accordance with the plans and specifications.

**NOT FOR CONSTRUCTION**

RECOMMENDED FOR APPROVAL	DESIGN ENGINEER	6/9/2021	DATE
DESIGNED: WCM	6/9/2021	DRAWN: WCM	6/9/2021
CHECKED: LNB	6/9/2021	CHECKED: LNB	6/9/2021

INDIANA  
DEPARTMENT OF TRANSPORTATION

CROSS SECTIONS  
LINE "B"

HORIZONTAL SCALE	BRIDGE FILE
1" = 5'	N/A
VERTICAL SCALE	DESIGNATION
1" = 5'	1900334
SURVEY BOOK	SHEETS
Electronic	53 of 89
CONTRACT	PROJECT
R-42228	1900334

Plot: 6/9/2021 7:58:31 PM

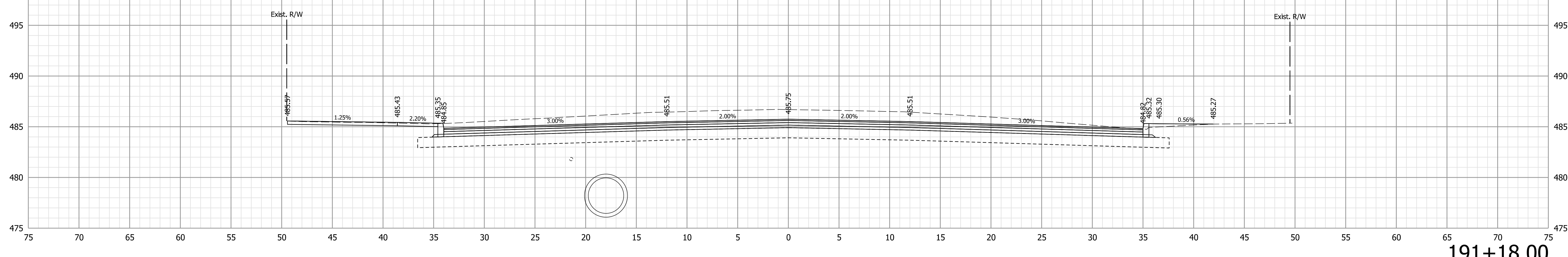
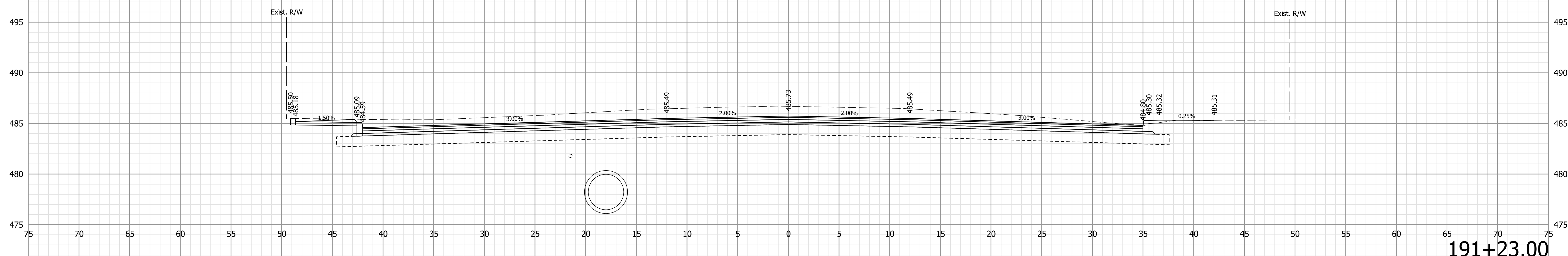
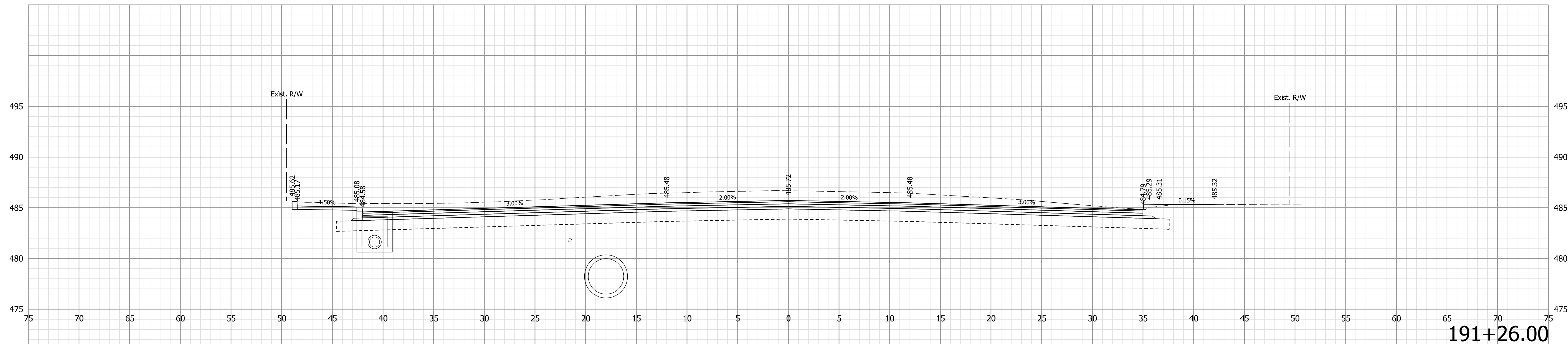

Note:  
 1. All utilities information shall be considered QL-D unless otherwise indicated and is for informational purposes only. The Contractor is responsible for locating and coordinating with utility companies in accordance with the plans and specifications.

**NOT FOR CONSTRUCTION**

RECOMMENDED FOR APPROVAL	DESIGN ENGINEER	6/9/2021	DATE
DESIGNED: WCM	6/9/2021	DRAWN: WCM	6/9/2021
CHECKED: LNB	6/9/2021	CHECKED: LNB	6/9/2021

INDIANA  
DEPARTMENT OF TRANSPORTATION

CROSS SECTIONS  
LINE "B"

HORIZONTAL SCALE	BRIDGE FILE
1" = 5'	N/A
VERTICAL SCALE	DESIGNATION
1" = 5'	1900334
SURVEY BOOK	SHEETS
Electronic	54 of 89
CONTRACT	PROJECT
R-42228	1900334

Plot: 6/9/2021 7:58:34 PM

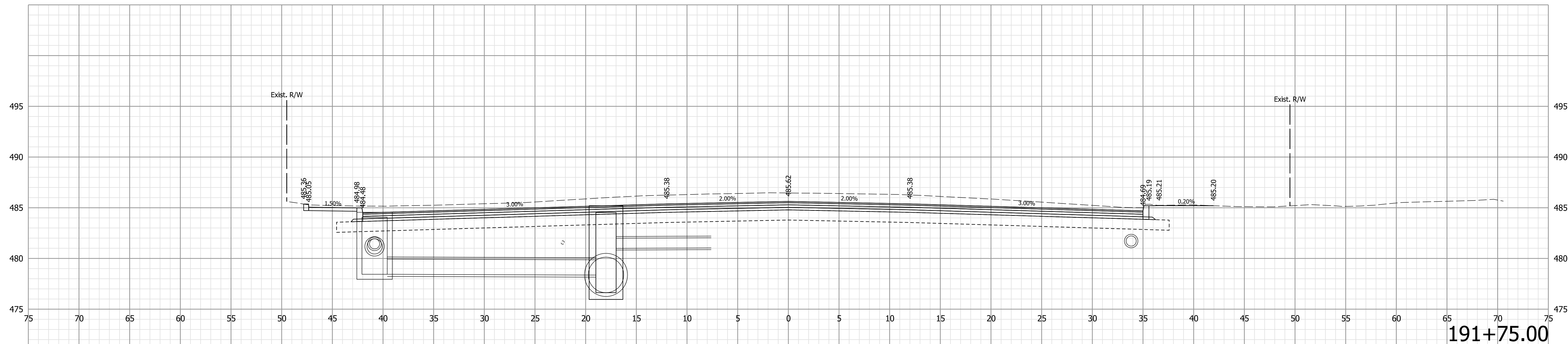

191+75.00

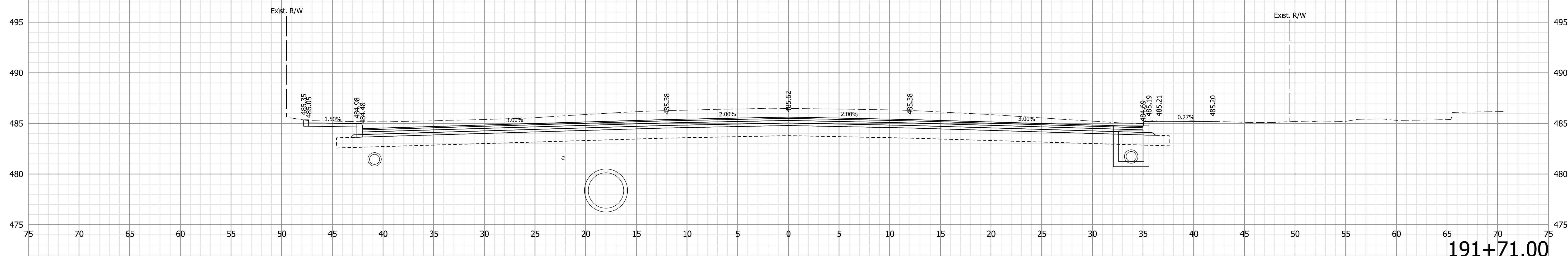

191+71.00

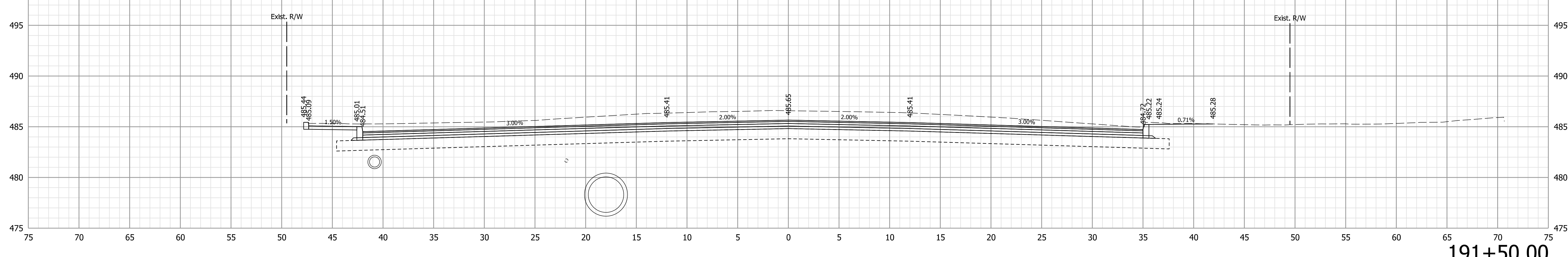

191+50.00

Note:  
1. All utilities information shall be considered QL-D unless otherwise indicated and is for informational purposes only. The Contractor is responsible for locating and coordinating with utility companies in accordance with the plans and specifications.

**NOT FOR CONSTRUCTION**

RECOMMENDED FOR APPROVAL	DESIGN ENGINEER	6/9/2021	DATE
DESIGNED: WCM	6/9/2021	DRAWN: WCM	6/9/2021
CHECKED: LNB	6/9/2021	CHECKED: LNB	6/9/2021

INDIANA  
DEPARTMENT OF TRANSPORTATION

CROSS SECTIONS  
LINE "B"

HORIZONTAL SCALE	BRIDGE FILE
1" = 5'	N/A
VERTICAL SCALE	DESIGNATION
1" = 5'	1900334
SURVEY BOOK	SHEETS
Electronic	55 of 89
CONTRACT	PROJECT
R-42228	1900334

Plot: 6/9/2021 7:58:37 PM

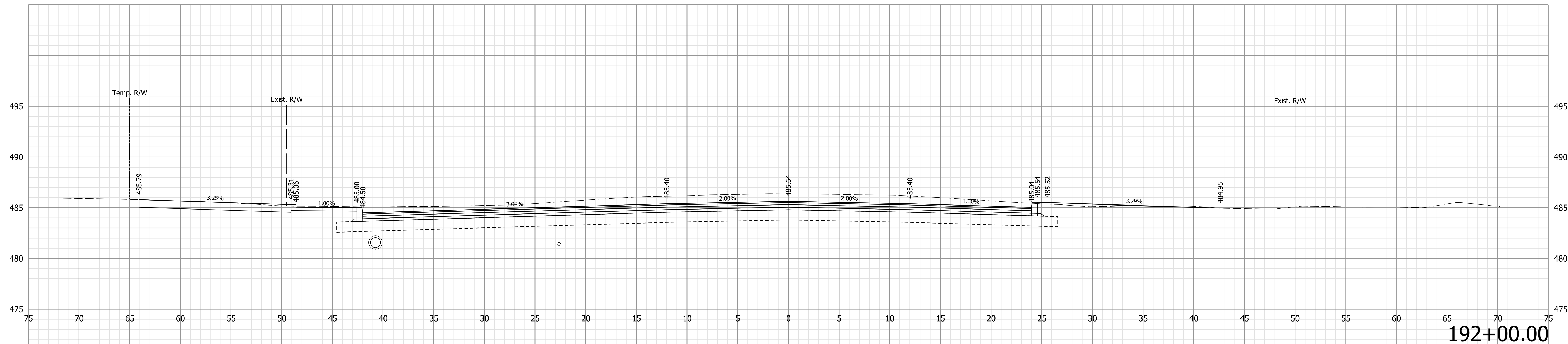

192+00.00

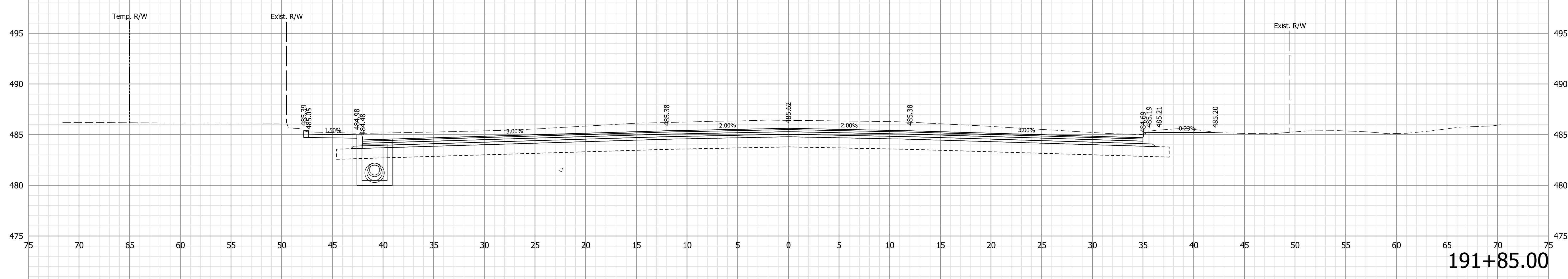

191+85.00

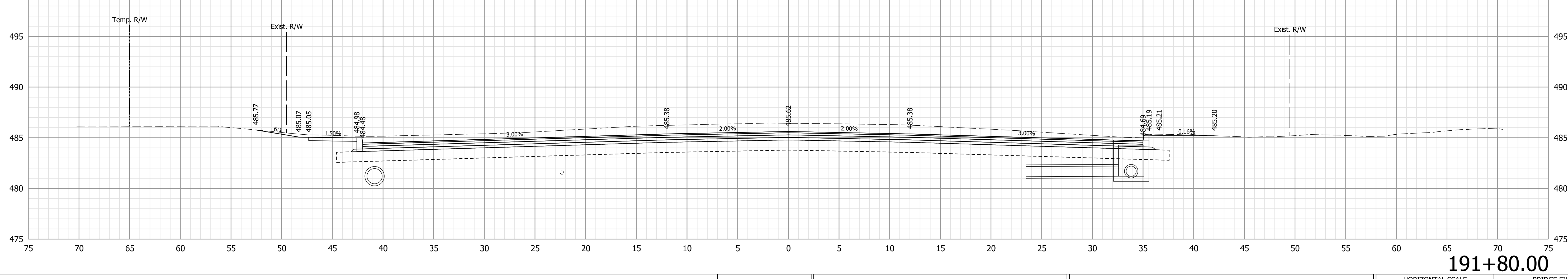

191+80.00

Note:  
 1. All utilities information shall be considered QL-D unless otherwise indicated and is for informational purposes only. The Contractor is responsible for locating and coordinating with utility companies in accordance with the plans and specifications.

**NOT FOR CONSTRUCTION**

RECOMMENDED FOR APPROVAL	DESIGN ENGINEER	6/9/2021	DATE
DESIGNED: WCM	6/9/2021	DRAWN: WCM	6/9/2021
CHECKED: LNB	6/9/2021	CHECKED: LNB	6/9/2021

INDIANA  
DEPARTMENT OF TRANSPORTATION

CROSS SECTIONS  
LINE "B"

HORIZONTAL SCALE	BRIDGE FILE
1" = 5'	N/A
VERTICAL SCALE	DESIGNATION
1" = 5'	1900334
SURVEY BOOK	SHEETS
Electronic	56 of 89
CONTRACT	PROJECT
R-42228	1900334

Plot: 6/9/2021 7:58:40 PM



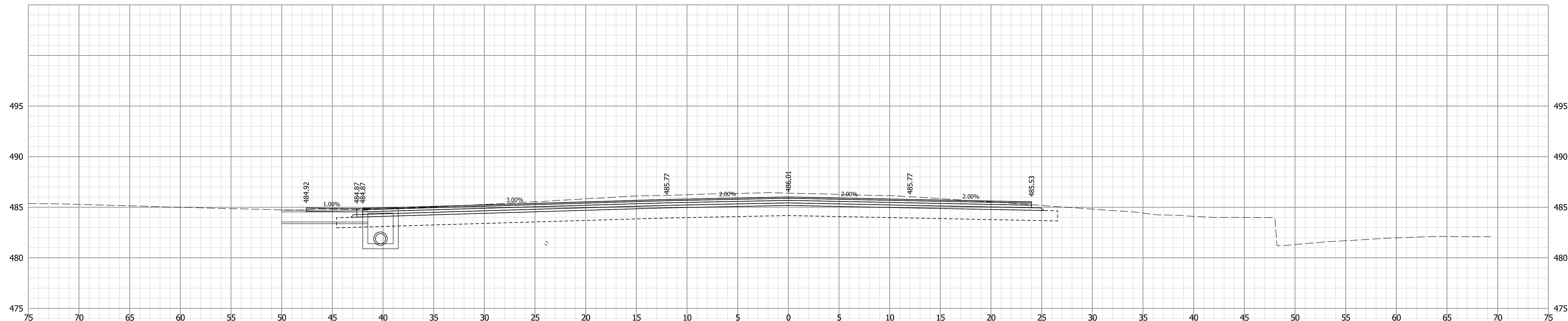

192+84.82

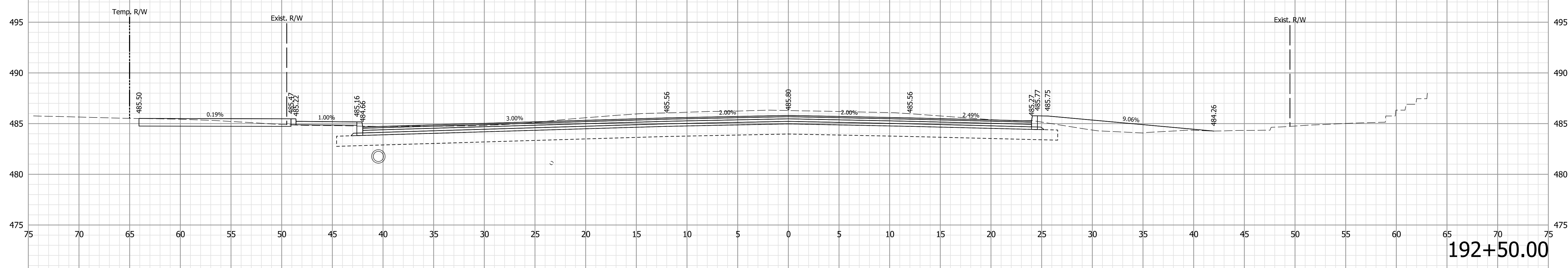

192+50.00

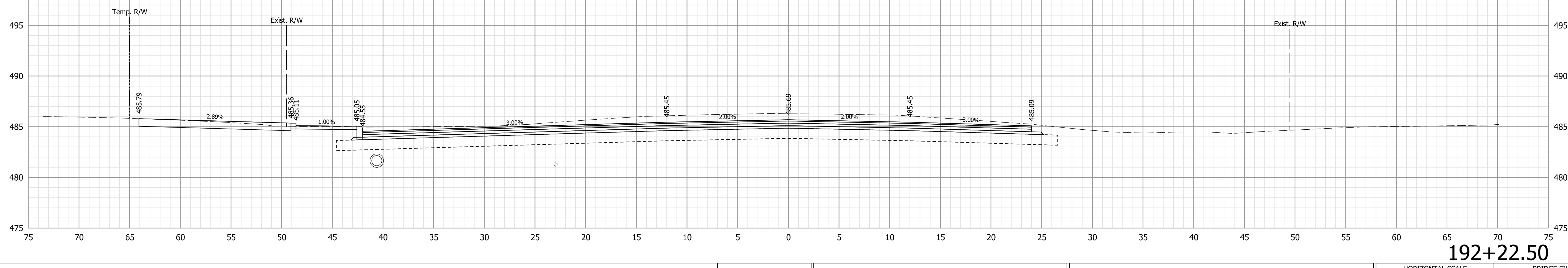

192+22.50

Note:  
 1. All utilities information shall be considered QL-D unless otherwise indicated and is for informational purposes only. The Contractor is responsible for locating and coordinating with utility companies in accordance with the plans and specifications.

**NOT FOR CONSTRUCTION**

RECOMMENDED FOR APPROVAL	DESIGN ENGINEER	6/9/2021	DATE
DESIGNED: WCM	6/9/2021	DRAWN: WCM	6/9/2021
CHECKED: LNB	6/9/2021	CHECKED: LNB	6/9/2021

INDIANA  
DEPARTMENT OF TRANSPORTATION

CROSS SECTIONS  
LINE "B"

HORIZONTAL SCALE	BRIDGE FILE
1" = 5'	N/A
VERTICAL SCALE	DESIGNATION
1" = 5'	1900334
SURVEY BOOK	SHEETS
Electronic	57 of 89
CONTRACT	PROJECT
R-42228	1900334

Plot: 6/9/2021 7:58:42 PM

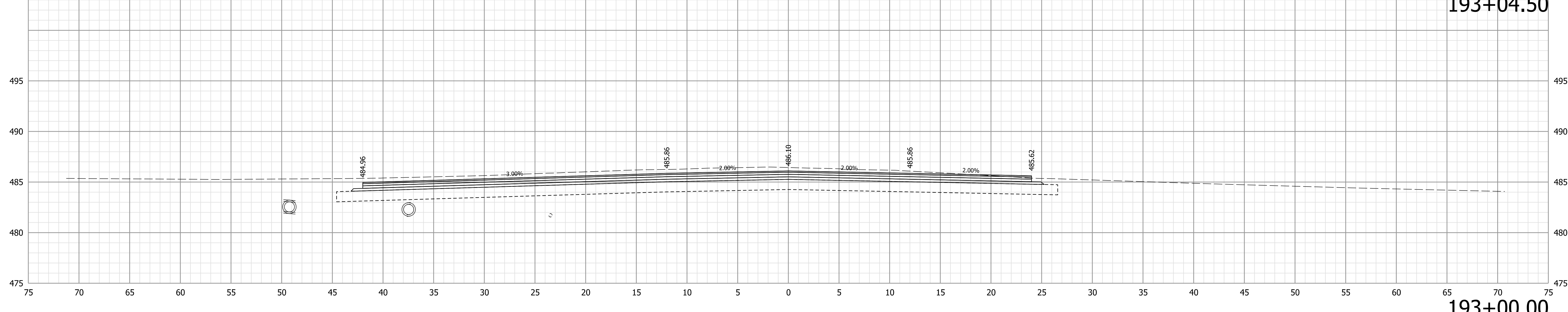
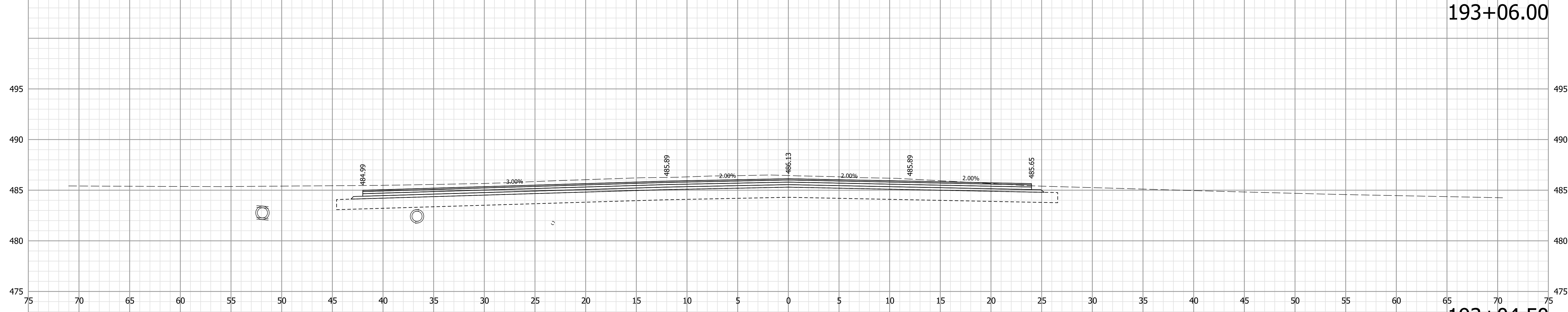
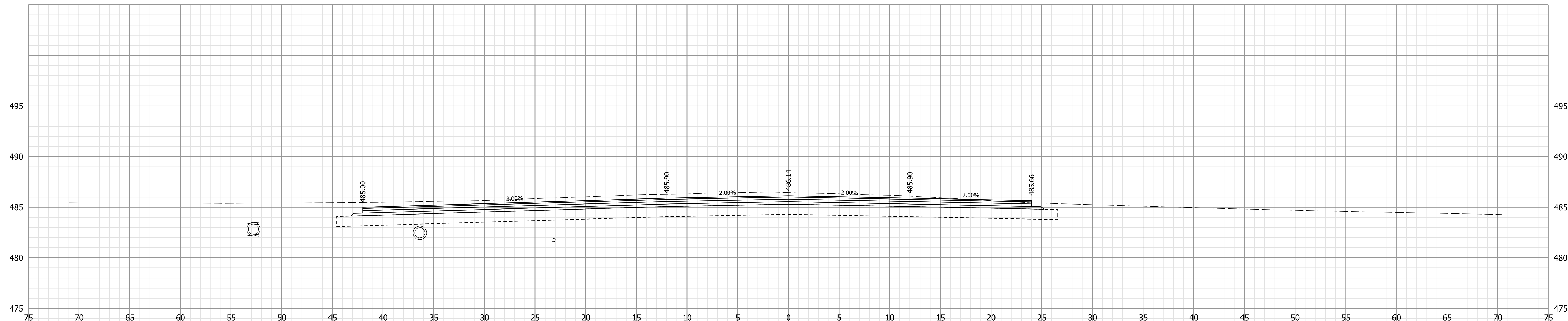

Note:  
 1. All utilities information shall be considered QL-D unless otherwise indicated and is for informational purposes only. The Contractor is responsible for locating and coordinating with utility companies in accordance with the plans and specifications.

**NOT FOR CONSTRUCTION**

RECOMMENDED FOR APPROVAL	DESIGN ENGINEER	6/9/2021	DATE
DESIGNED: WCM	6/9/2021	DRAWN: WCM	6/9/2021
CHECKED: LNB	6/9/2021	CHECKED: LNB	6/9/2021

INDIANA  
DEPARTMENT OF TRANSPORTATION

CROSS SECTIONS  
LINE "B"

HORIZONTAL SCALE	BRIDGE FILE
1" = 5'	N/A
VERTICAL SCALE	DESIGNATION
1" = 5'	1900334
SURVEY BOOK	SHEETS
Electronic	58 of 89
CONTRACT	PROJECT
R-42228	1900334

Plot: 6/9/2021 7:58:45 PM

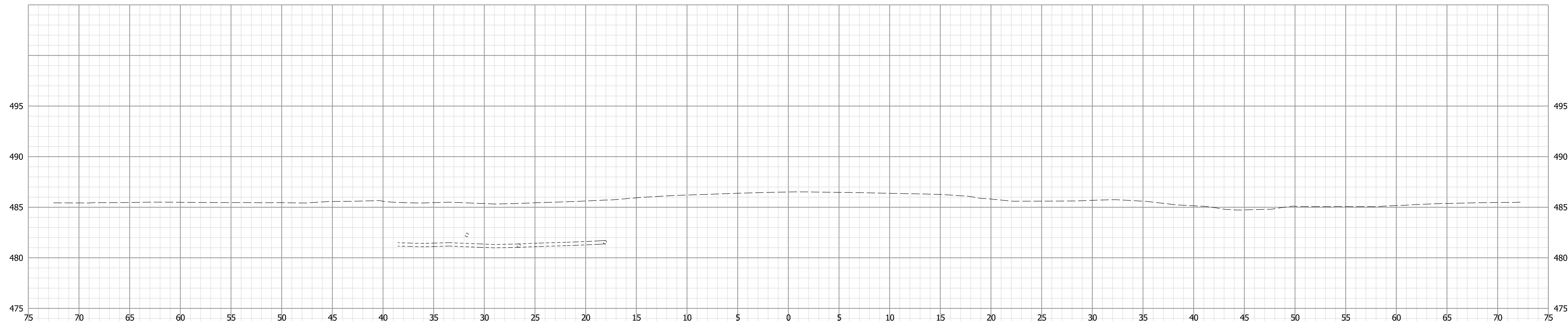

194+00.00

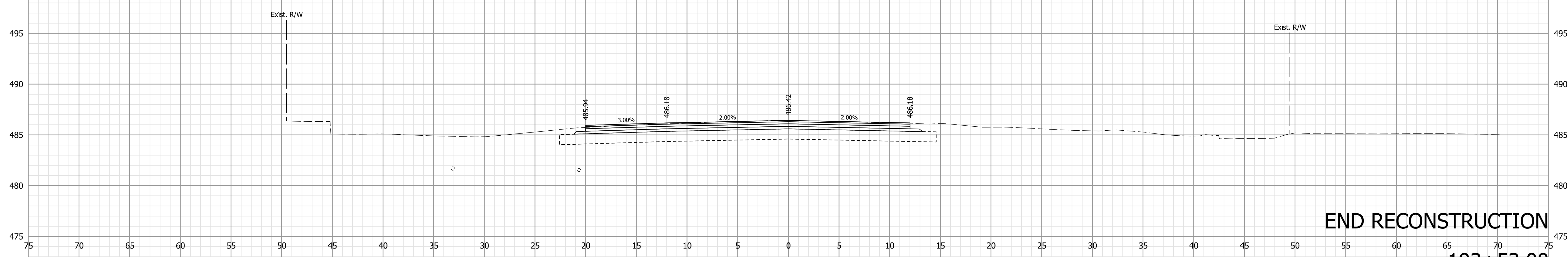

END RECONSTRUCTION

193+53.00

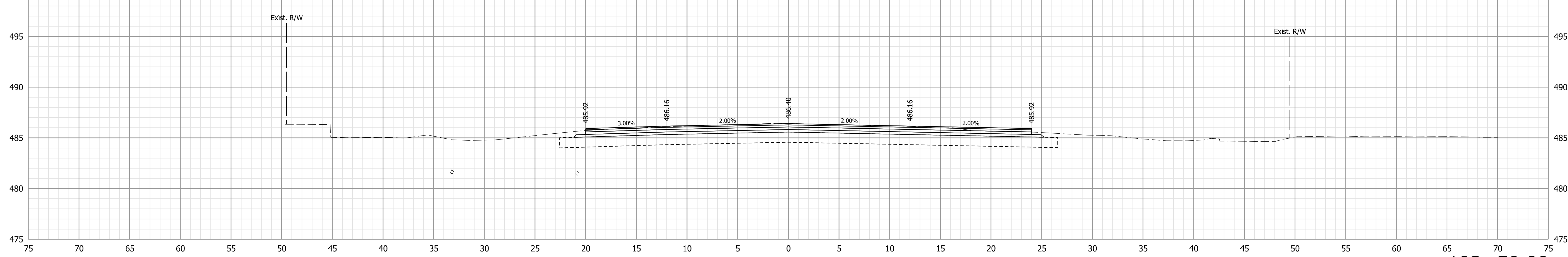

193+50.00

Note:  
1. All utilities information shall be considered QL-D unless otherwise indicated and is for informational purposes only. The Contractor is responsible for locating and coordinating with utility companies in accordance with the plans and specifications.

**NOT FOR CONSTRUCTION**

RECOMMENDED FOR APPROVAL	DESIGN ENGINEER	6/9/2021	DATE
DESIGNED: WCM	6/9/2021	DRAWN: WCM	6/9/2021
CHECKED: LNB	6/9/2021	CHECKED: LNB	6/9/2021

INDIANA  
DEPARTMENT OF TRANSPORTATION

CROSS SECTIONS  
LINE "B"

HORIZONTAL SCALE	BRIDGE FILE
1" = 5'	N/A
VERTICAL SCALE	DESIGNATION
1" = 5'	1900334
SURVEY BOOK	SHEETS
Electronic	59 of 89
CONTRACT	PROJECT
R-42228	1900334

Plot: 6/9/2021 7:58:48 PM

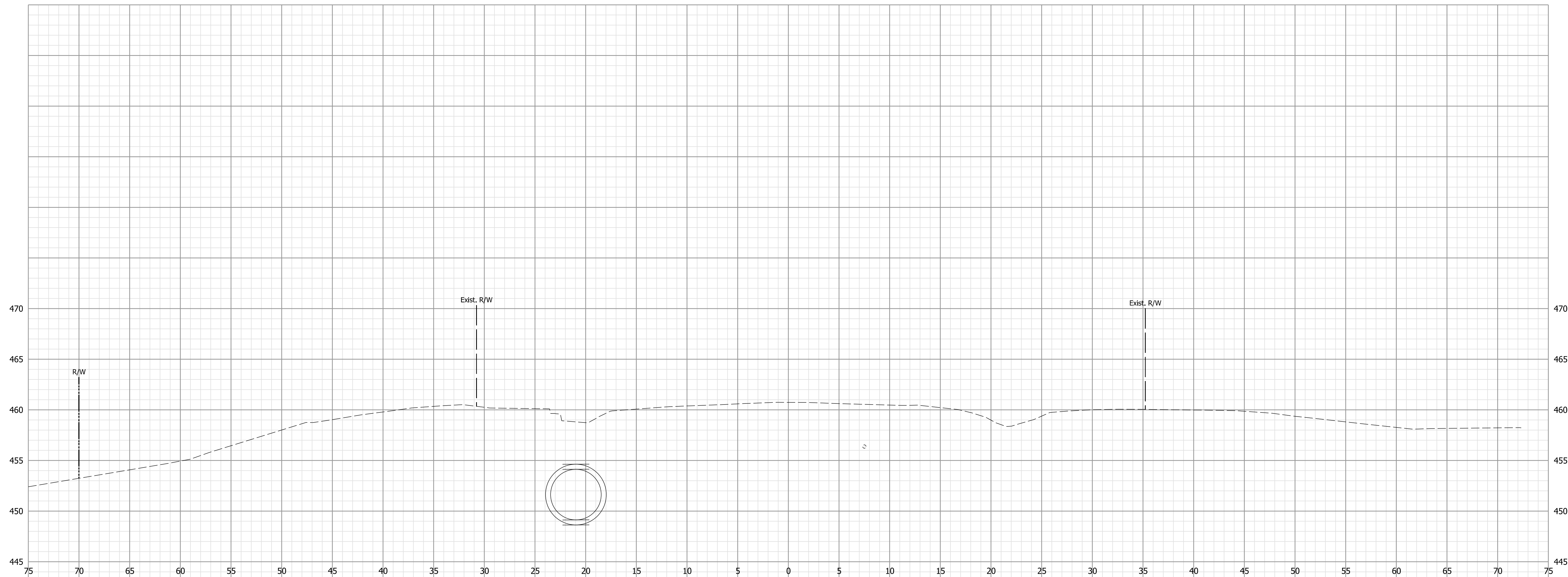

302+50.00

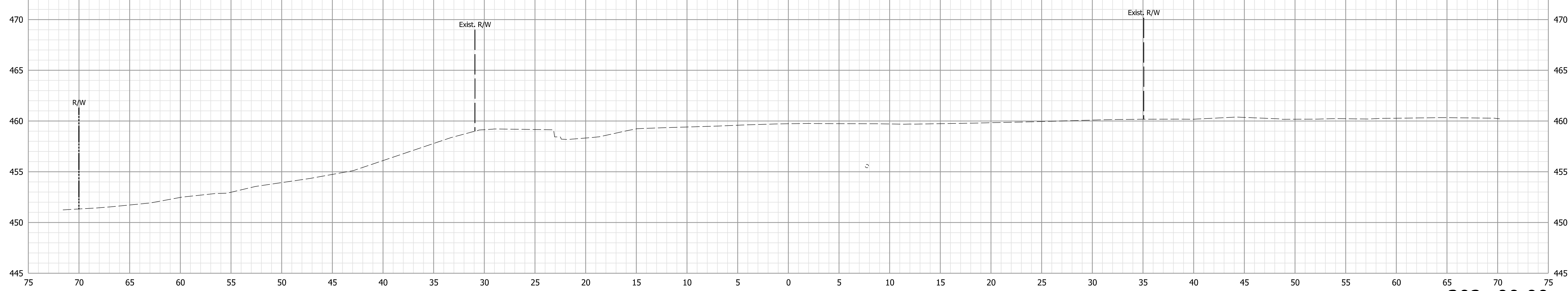

302+00.00

Note:  
 1. All utilities information shall be considered QL-D unless otherwise indicated and is for informational purposes only. The Contractor is responsible for locating and coordinating with utility companies in accordance with the plans and specifications.

**NOT FOR CONSTRUCTION**

RECOMMENDED FOR APPROVAL	DESIGN ENGINEER	6/9/2021	DATE
DESIGNED: WCM	6/9/2021	DRAWN: WCM	6/9/2021
CHECKED: LNB	6/9/2021	CHECKED: LNB	6/9/2021

INDIANA  
DEPARTMENT OF TRANSPORTATION

CROSS SECTIONS  
LINE "D"

HORIZONTAL SCALE	BRIDGE FILE
1" = 5'	N/A
VERTICAL SCALE	DESIGNATION
1" = 5'	1900334
SURVEY BOOK	SHEETS
Electronic	60 of 89
CONTRACT	PROJECT
R-42228	1900334

Plot: 6/9/2021 7:59:37 PM

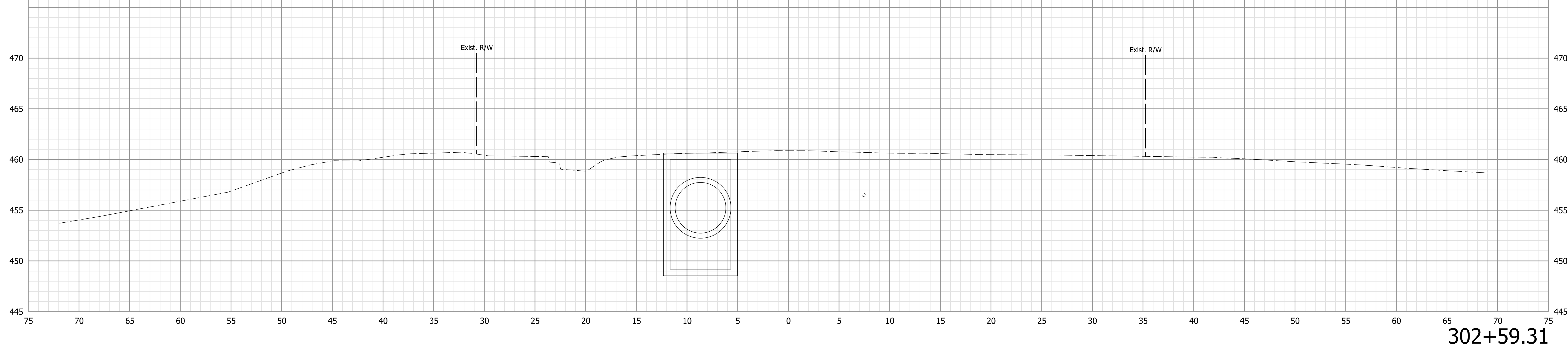
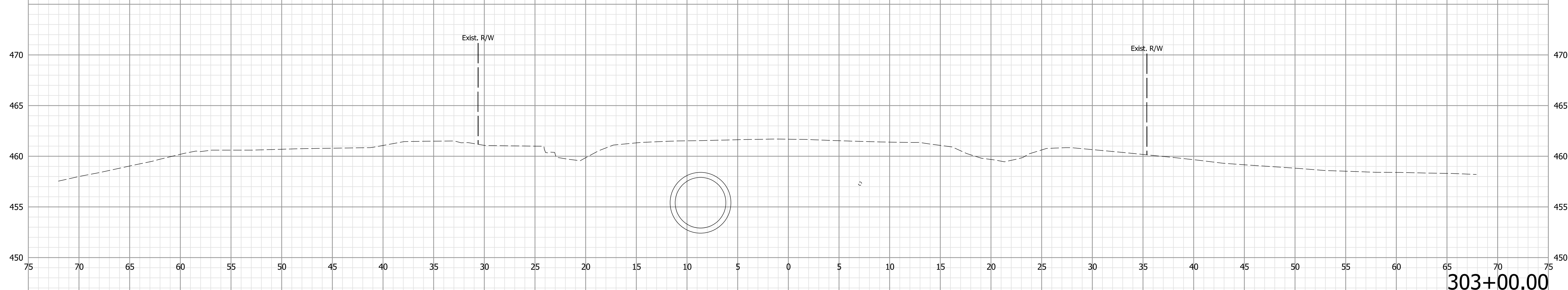
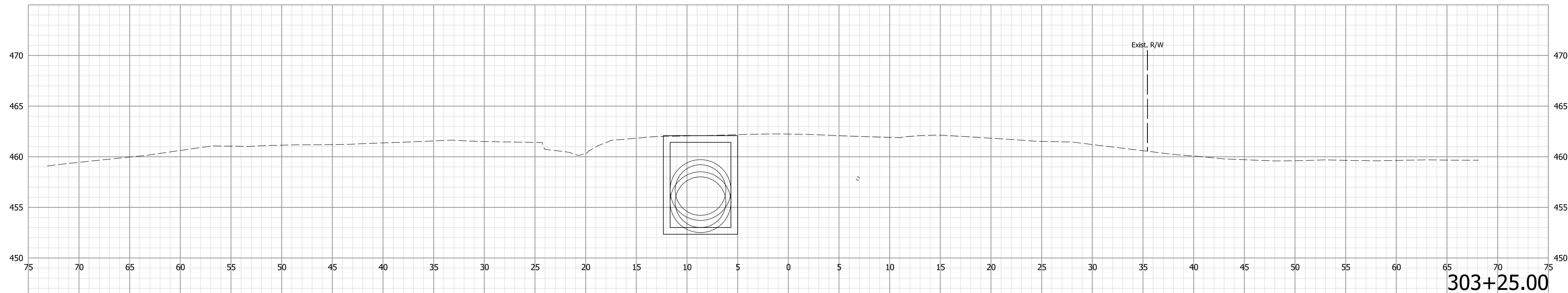

Note:  
 1. All utilities information shall be considered QL-D unless otherwise indicated and is for informational purposes only. The Contractor is responsible for locating and coordinating with utility companies in accordance with the plans and specifications.

**NOT FOR CONSTRUCTION**

RECOMMENDED FOR APPROVAL	DESIGN ENGINEER	6/9/2021	DATE
DESIGNED: WCM	6/9/2021	DRAWN: WCM	6/9/2021
CHECKED: LNB	6/9/2021	CHECKED: LNB	6/9/2021

INDIANA  
DEPARTMENT OF TRANSPORTATION

CROSS SECTIONS  
LINE "D"

HORIZONTAL SCALE	BRIDGE FILE
1" = 5'	N/A
VERTICAL SCALE	DESIGNATION
1" = 5'	1900334
SURVEY BOOK	SHEETS
Electronic	61 of 89
CONTRACT	PROJECT
R-42228	1900334

Plot: 6/9/2021 7:59:43 PM

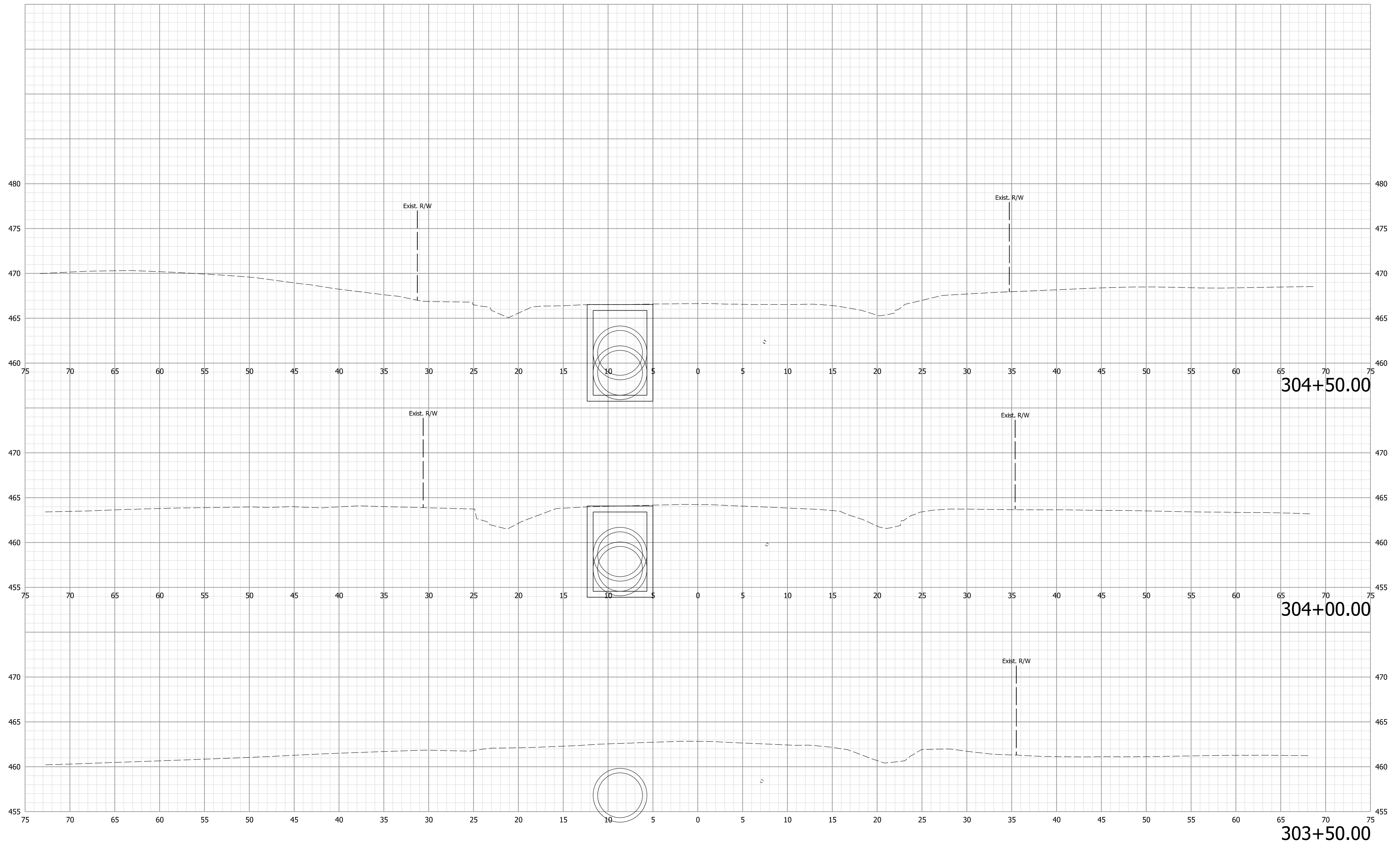

Note:  
 1. All utilities information shall be considered QL-D unless otherwise indicated and is for informational purposes only. The Contractor is responsible for locating and coordinating with utility companies in accordance with the plans and specifications.

**NOT FOR CONSTRUCTION**

RECOMMENDED FOR APPROVAL	DESIGN ENGINEER	6/9/2021	DATE
DESIGNED: WCM	6/9/2021	DRAWN: WCM	6/9/2021
CHECKED: LNB	6/9/2021	CHECKED: LNB	6/9/2021

INDIANA  
DEPARTMENT OF TRANSPORTATION

CROSS SECTIONS  
LINE "D"

HORIZONTAL SCALE	BRIDGE FILE
1" = 5'	N/A
VERTICAL SCALE	DESIGNATION
1" = 5'	1900334
SURVEY BOOK	SHEETS
Electronic	62 of 89
CONTRACT	PROJECT
R-42228	1900334

Plot: 6/9/2021 7:59:48 PM

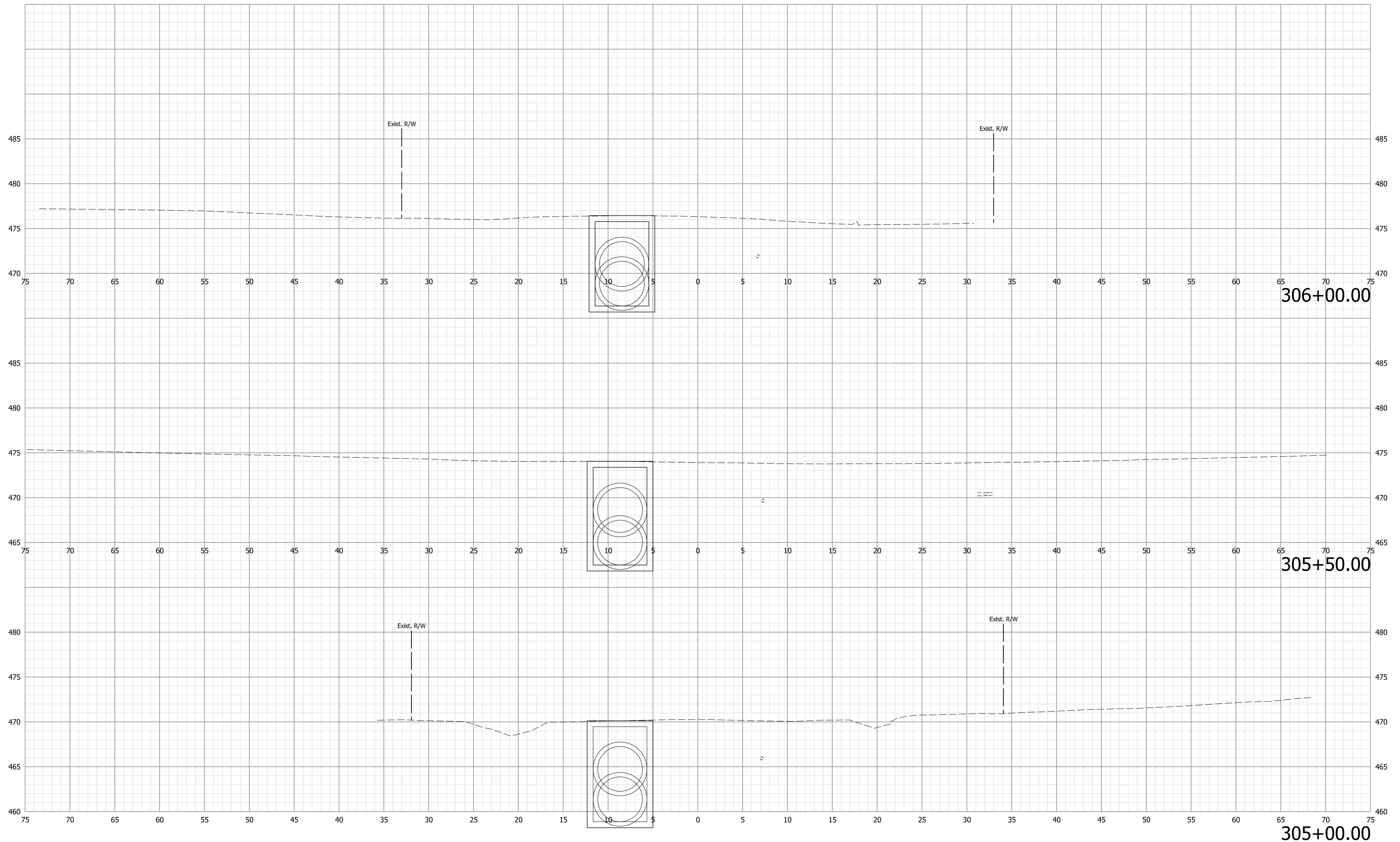

Note:  
 1. All utilities information shall be considered QL-D unless otherwise indicated and is for informational purposes only. The Contractor is responsible for locating and coordinating with utility companies in accordance with the plans and specifications.

**NOT FOR CONSTRUCTION**

RECOMMENDED FOR APPROVAL	DESIGN ENGINEER	6/9/2021	DATE
DESIGNED: WCM	6/9/2021	DRAWN: WCM	6/9/2021
CHECKED: LNB	6/9/2021	CHECKED: LNB	6/9/2021

INDIANA  
DEPARTMENT OF TRANSPORTATION

CROSS SECTIONS  
LINE "D"

HORIZONTAL SCALE	BRIDGE FILE
1" = 5'	N/A
VERTICAL SCALE	DESIGNATION
1" = 5'	1900334
SURVEY BOOK	SHEETS
Electronic	63 of 89
CONTRACT	PROJECT
R-42228	1900334

Plot: 6/9/2021 7:59:53 PM

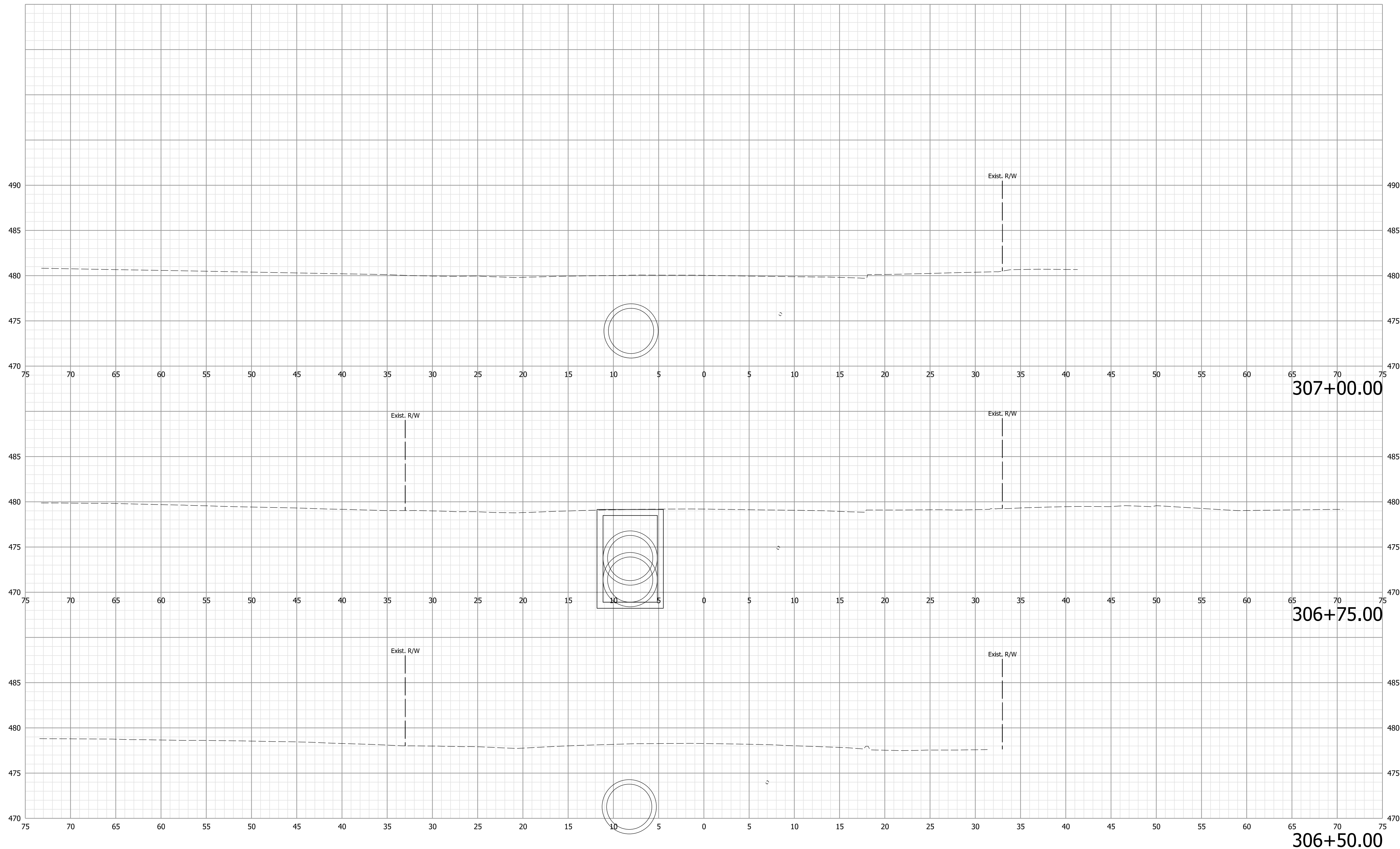

Note:  
 1. All utilities information shall be considered QL-D unless otherwise indicated and is for informational purposes only. The Contractor is responsible for locating and coordinating with utility companies in accordance with the plans and specifications.

**NOT FOR CONSTRUCTION**

RECOMMENDED FOR APPROVAL	DESIGN ENGINEER	6/9/2021	DATE
DESIGNED: WCM	6/9/2021	DRAWN: WCM	6/9/2021
CHECKED: LNB	6/9/2021	CHECKED: LNB	6/9/2021

INDIANA  
DEPARTMENT OF TRANSPORTATION

CROSS SECTIONS  
LINE "D"

HORIZONTAL SCALE	BRIDGE FILE
1" = 5'	N/A
VERTICAL SCALE	DESIGNATION
1" = 5'	1900334
SURVEY BOOK	SHEETS
Electronic	64 of 89
CONTRACT	PROJECT
R-42228	1900334

Plot: 6/9/2021 7:59:59 PM



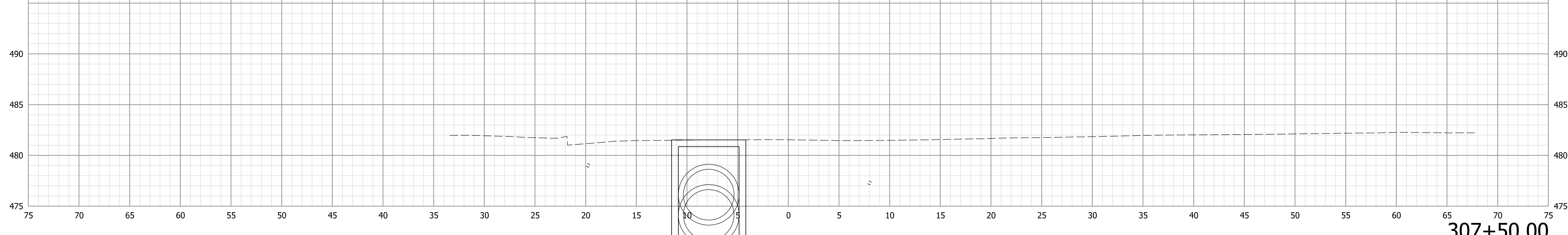
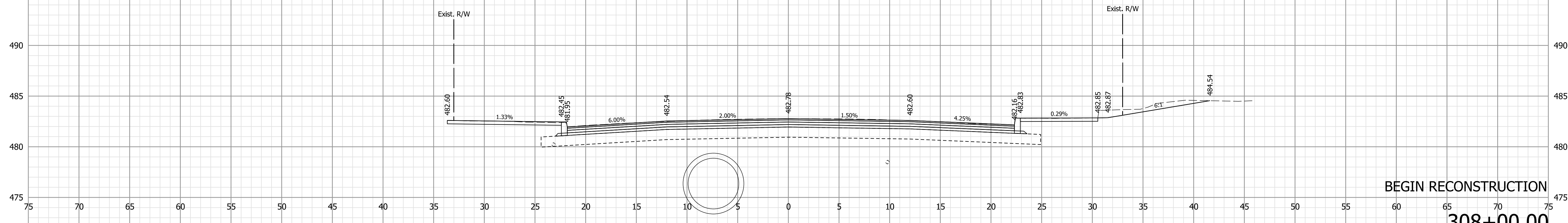
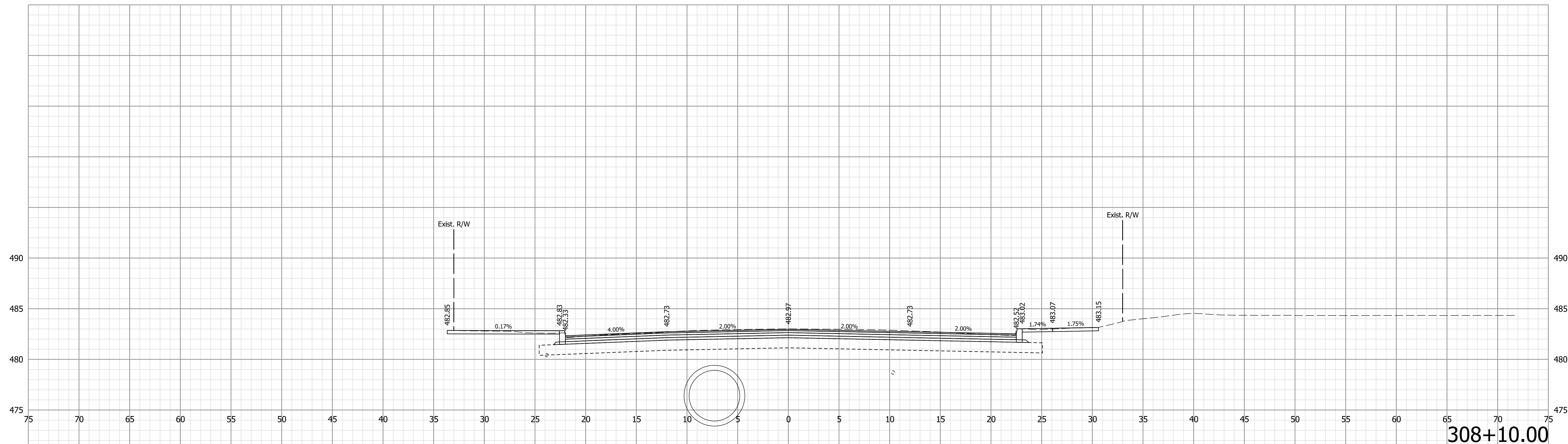

Note:  
 1. All utilities information shall be considered QL-D unless otherwise indicated and is for informational purposes only. The Contractor is responsible for locating and coordinating with utility companies in accordance with the plans and specifications.

NOT FOR CONSTRUCTION

RECOMMENDED FOR APPROVAL	DESIGN ENGINEER	6/9/2021	DATE
DESIGNED: WCM	6/9/2021	DRAWN: WCM	6/9/2021
CHECKED: LNB	6/9/2021	CHECKED: LNB	6/9/2021

INDIANA  
DEPARTMENT OF TRANSPORTATION

CROSS SECTIONS  
LINE "D"

HORIZONTAL SCALE	BRIDGE FILE
1" = 5'	N/A
VERTICAL SCALE	DESIGNATION
1" = 5'	1900334
SURVEY BOOK	SHEETS
Electronic	65 of 89
CONTRACT	PROJECT
R-42228	1900334

Plot: 6/9/2021 8:00:04 PM

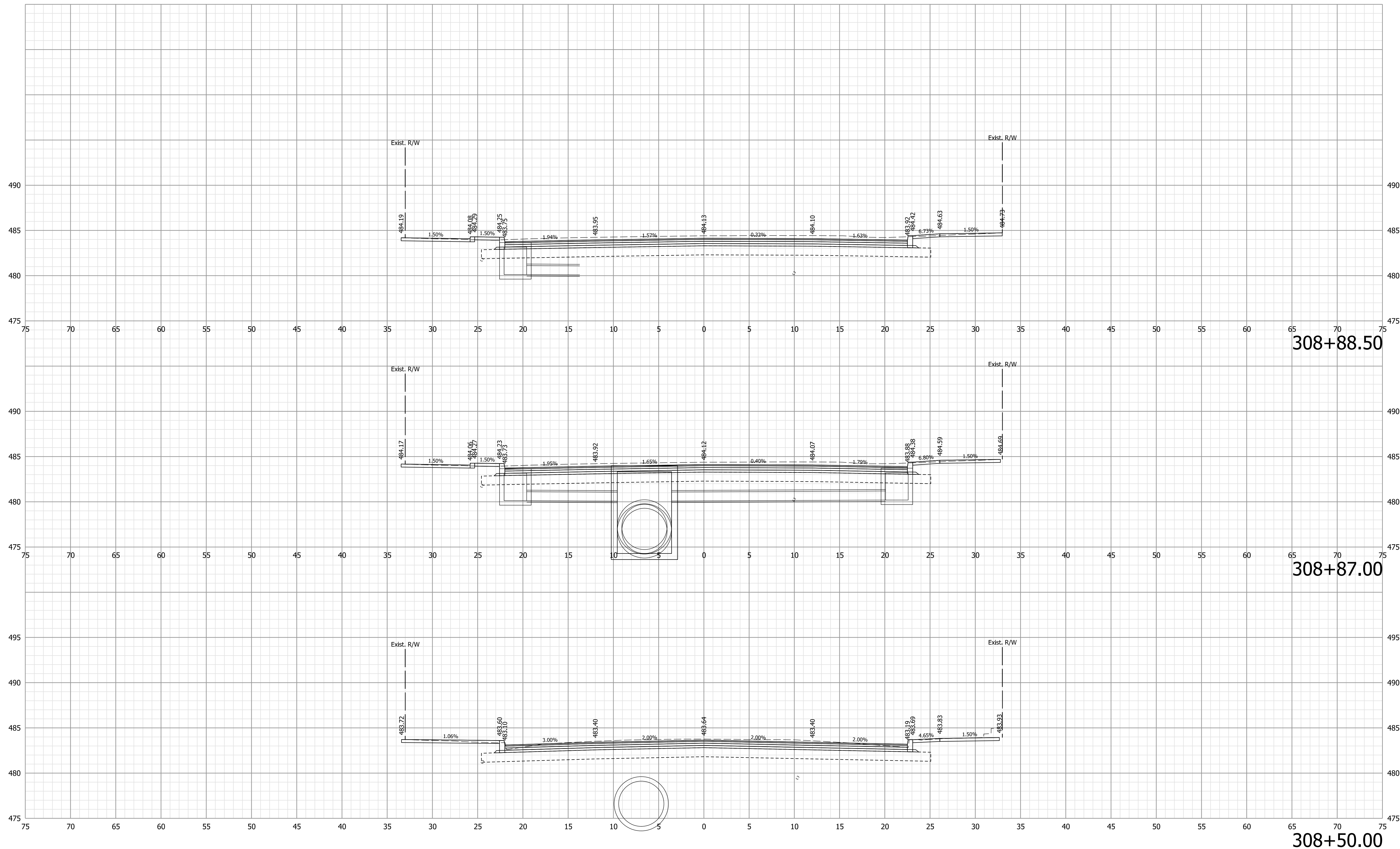

308+88.50

308+87.00

308+50.00

Note:

1. All utilities information shall be considered QL-D unless otherwise indicated and is for informational purposes only. The Contractor is responsible for locating and coordinating with utility companies in accordance with the plans and specifications.

**NOT FOR CONSTRUCTION**

RECOMMENDED FOR APPROVAL	DESIGN ENGINEER	6/9/2021	DATE
DESIGNED: WCM	6/9/2021	DRAWN: WCM	6/9/2021
CHECKED: LNB	6/9/2021	CHECKED: LNB	6/9/2021

INDIANA  
DEPARTMENT OF TRANSPORTATION

CROSS SECTIONS  
LINE "D"

HORIZONTAL SCALE	BRIDGE FILE
1" = 5'	N/A
VERTICAL SCALE	DESIGNATION
1" = 5'	1900334
SURVEY BOOK	SHEETS
Electronic	66 of 89
CONTRACT	PROJECT
R-42228	1900334

Plot: 6/9/2021 8:00:10 PM

SEE LINE "B" CROSS SECTIONS

309+50.00

309+08.45

309+00.00

Plotted: 6/9/2021 8:00:15 PM

Note:  
 1. All utilities information shall be considered QL-D unless otherwise indicated and is for informational purposes only. The Contractor is responsible for locating and coordinating with utility companies in accordance with the plans and specifications.

**NOT FOR CONSTRUCTION**

RECOMMENDED FOR APPROVAL	DESIGN ENGINEER	6/9/2021	DATE
DESIGNED: WCM	6/9/2021	DRAWN: WCM	6/9/2021
CHECKED: LNB	6/9/2021	CHECKED: LNB	6/9/2021

INDIANA  
DEPARTMENT OF TRANSPORTATION

CROSS SECTIONS  
LINE "D"

HORIZONTAL SCALE	BRIDGE FILE
1" = 5'	N/A
VERTICAL SCALE	DESIGNATION
1" = 5'	1900334
SURVEY BOOK	SHEETS
Electronic	67 of 89
CONTRACT	PROJECT
R-42228	1900334

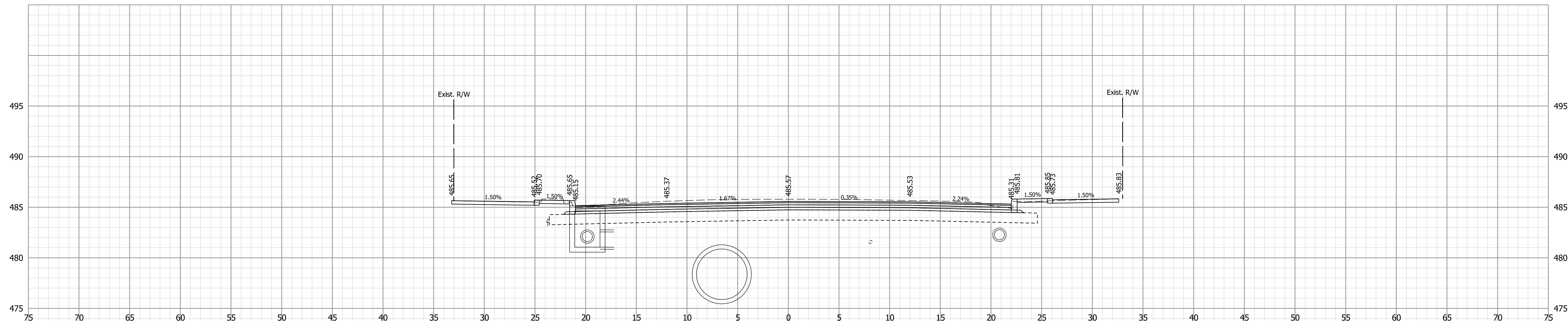

309+98.00

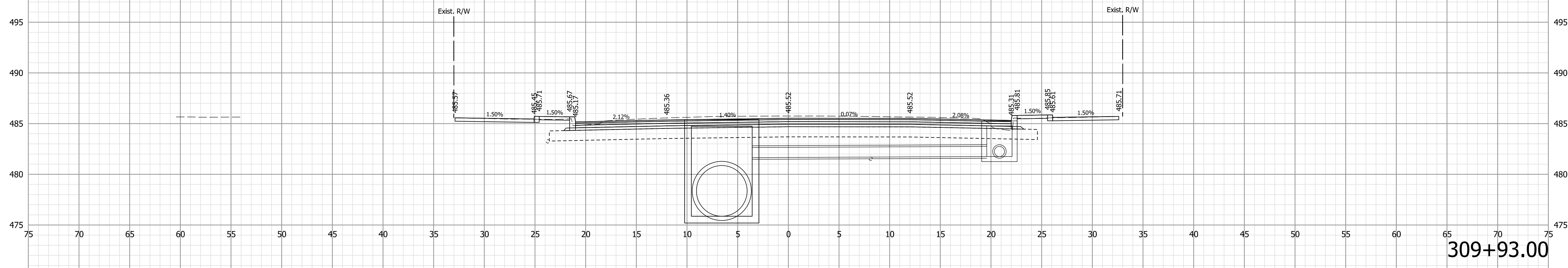

309+93.00

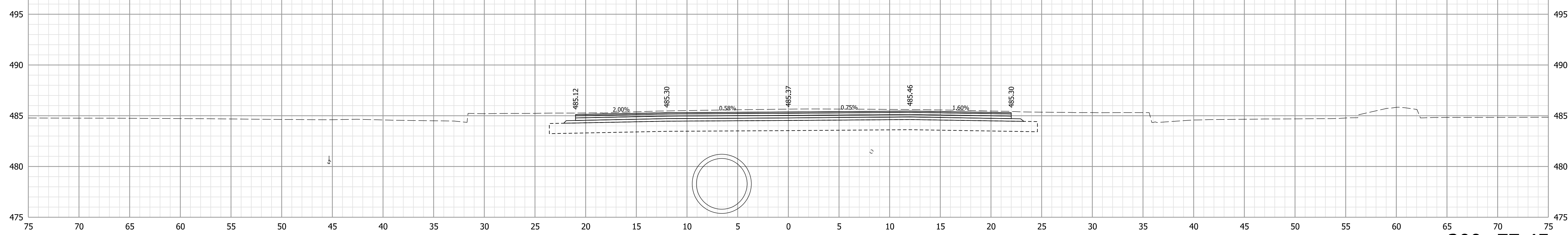

309+77.45

Note:  
 1. All utilities information shall be considered QL-D unless otherwise indicated and is for informational purposes only. The Contractor is responsible for locating and coordinating with utility companies in accordance with the plans and specifications.

NOT FOR CONSTRUCTION

RECOMMENDED FOR APPROVAL	DESIGN ENGINEER	6/9/2021	DATE
DESIGNED: WCM	6/9/2021	DRAWN: WCM	6/9/2021
CHECKED: LNB	6/9/2021	CHECKED: LNB	6/9/2021

INDIANA  
DEPARTMENT OF TRANSPORTATION

CROSS SECTIONS  
LINE "D"

HORIZONTAL SCALE	BRIDGE FILE
1" = 5'	N/A
VERTICAL SCALE	DESIGNATION
1" = 5'	1900334
SURVEY BOOK	SHEETS
Electronic	68 of 89
CONTRACT	PROJECT
R-42228	1900334

Plot: 6/9/2021 8:00:21 PM

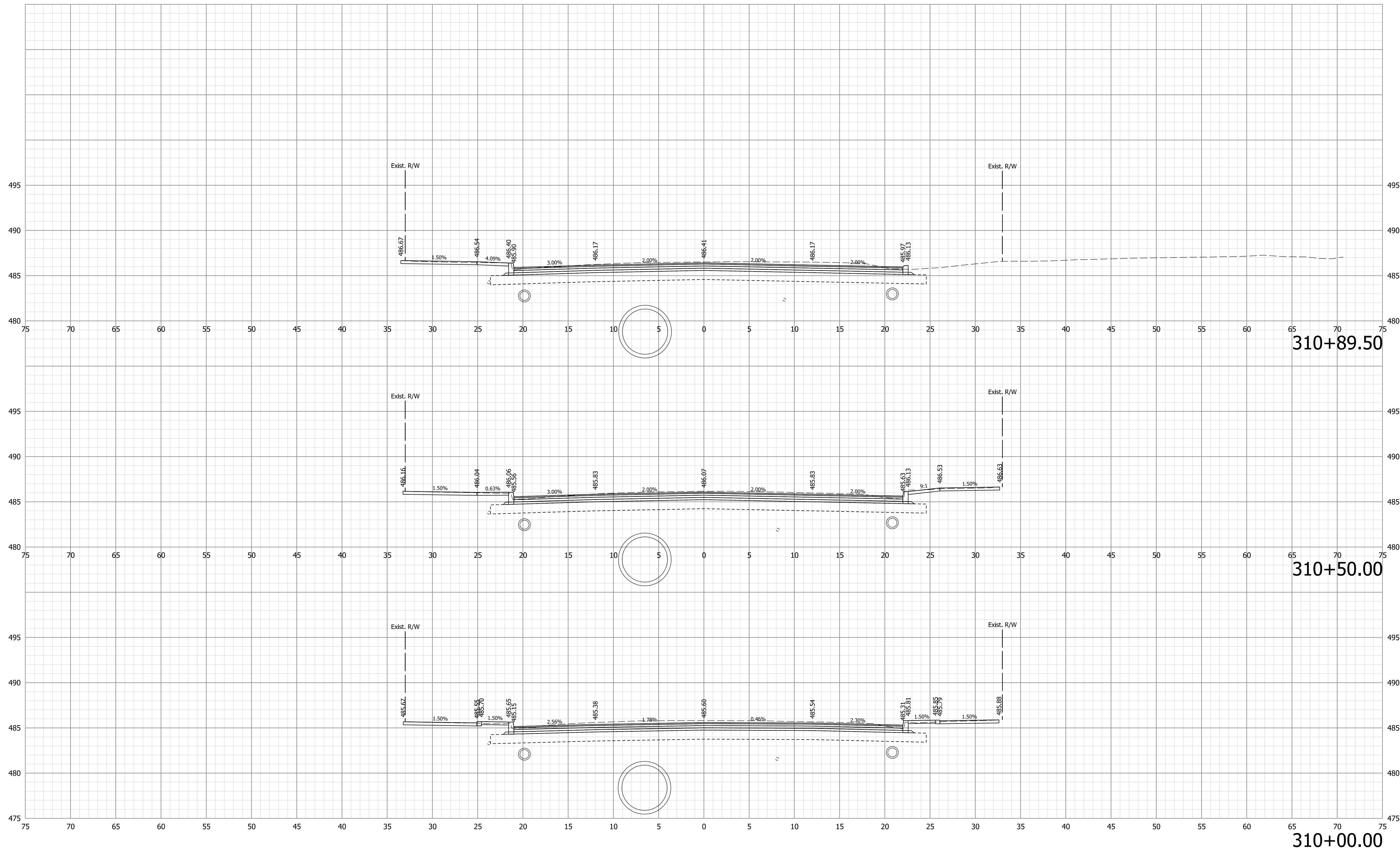

Note:  
 1. All utilities information shall be considered QL-D unless otherwise indicated and is for informational purposes only. The Contractor is responsible for locating and coordinating with utility companies in accordance with the plans and specifications.

**NOT FOR CONSTRUCTION**

RECOMMENDED FOR APPROVAL	DESIGN ENGINEER	6/9/2021	DATE
DESIGNED: WCM	6/9/2021	DRAWN: WCM	6/9/2021
CHECKED: LNB	6/9/2021	CHECKED: LNB	6/9/2021

INDIANA  
DEPARTMENT OF TRANSPORTATION

CROSS SECTIONS  
LINE "D"

HORIZONTAL SCALE	BRIDGE FILE
1" = 5'	N/A
VERTICAL SCALE	DESIGNATION
1" = 5'	1900334
SURVEY BOOK	SHEETS
Electronic	69 of 89
CONTRACT	PROJECT
R-42228	1900334

Plot: 6/9/2021 8:00:27 PM

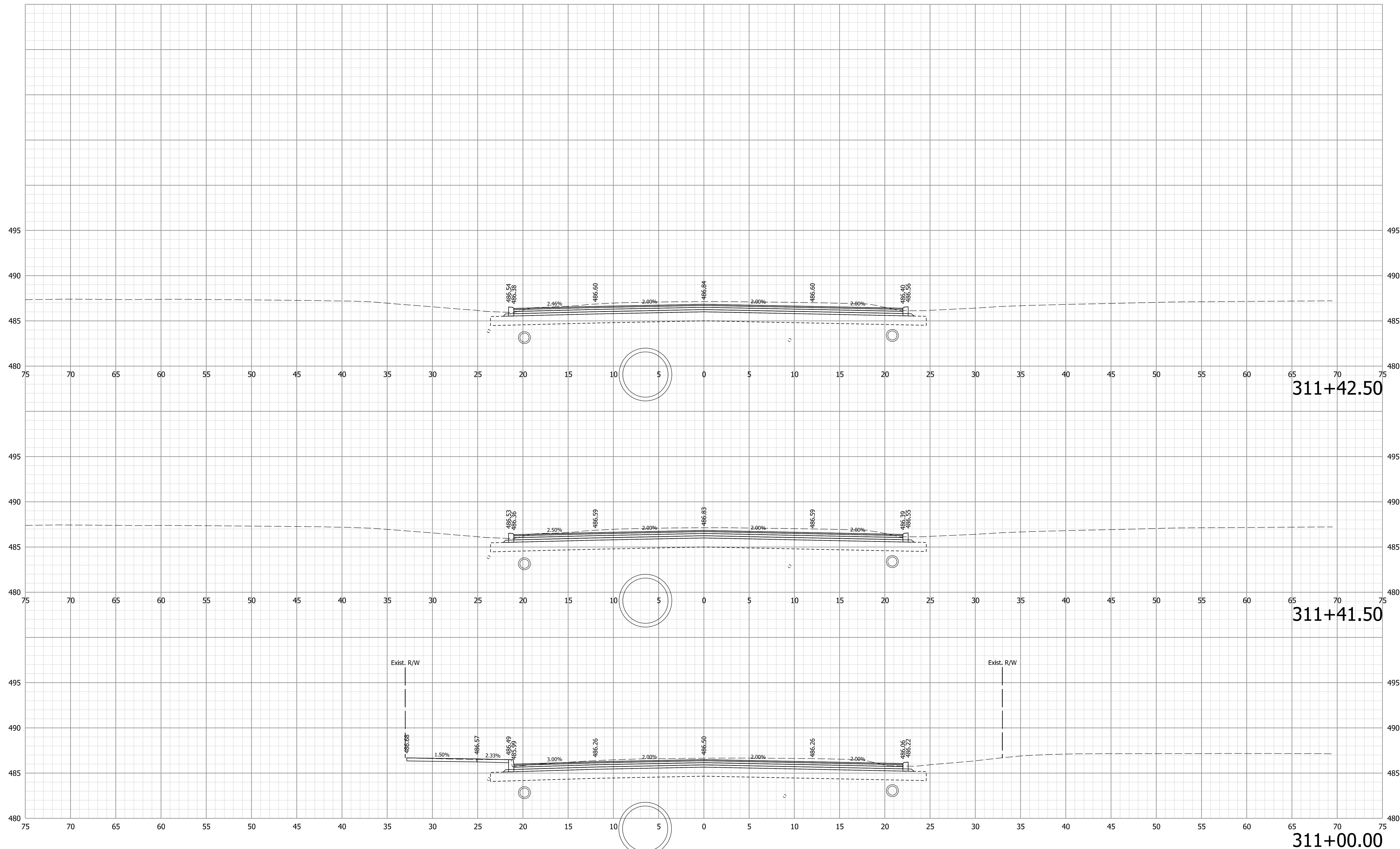

Note:  
 1. All utilities information shall be considered QL-D unless otherwise indicated and is for informational purposes only. The Contractor is responsible for locating and coordinating with utility companies in accordance with the plans and specifications.

**NOT FOR CONSTRUCTION**

RECOMMENDED FOR APPROVAL	DESIGN ENGINEER	6/9/2021	DATE
DESIGNED: WCM	6/9/2021	DRAWN: WCM	6/9/2021
CHECKED: LNB	6/9/2021	CHECKED: LNB	6/9/2021

INDIANA  
DEPARTMENT OF TRANSPORTATION

CROSS SECTIONS  
LINE "D"

HORIZONTAL SCALE	BRIDGE FILE
1" = 5'	N/A
VERTICAL SCALE	DESIGNATION
1" = 5'	1900334
SURVEY BOOK	SHEETS
Electronic	70 of 89
CONTRACT	PROJECT
R-42228	1900334

Plot: 6/9/2021 8:00:33 PM

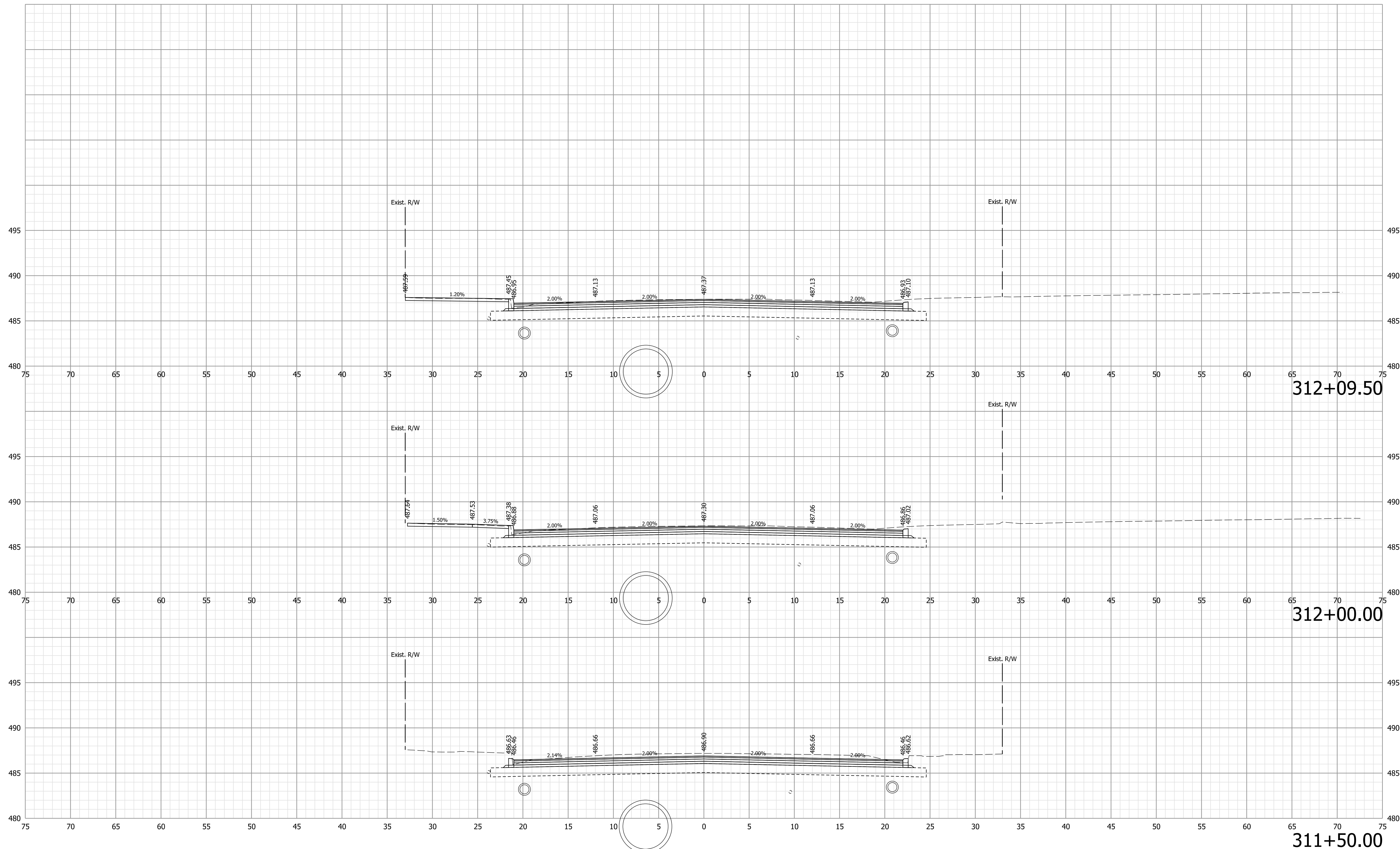

312+09.50

312+00.00

311+50.00

Note:  
 1. All utilities information shall be considered QL-D unless otherwise indicated and is for informational purposes only. The Contractor is responsible for locating and coordinating with utility companies in accordance with the plans and specifications.

**NOT FOR CONSTRUCTION**

RECOMMENDED FOR APPROVAL	DESIGN ENGINEER	6/9/2021	DATE
DESIGNED: WCM	6/9/2021	DRAWN: WCM	6/9/2021
CHECKED: LNB	6/9/2021	CHECKED: LNB	6/9/2021

INDIANA  
 DEPARTMENT OF TRANSPORTATION

CROSS SECTIONS  
 LINE "D"

HORIZONTAL SCALE	BRIDGE FILE
1" = 5'	N/A
VERTICAL SCALE	DESIGNATION
1" = 5'	1900334
SURVEY BOOK	SHEETS
Electronic	71 of 89
CONTRACT	PROJECT
R-42228	1900334

Plot: 6/9/2021 8:00:38 PM

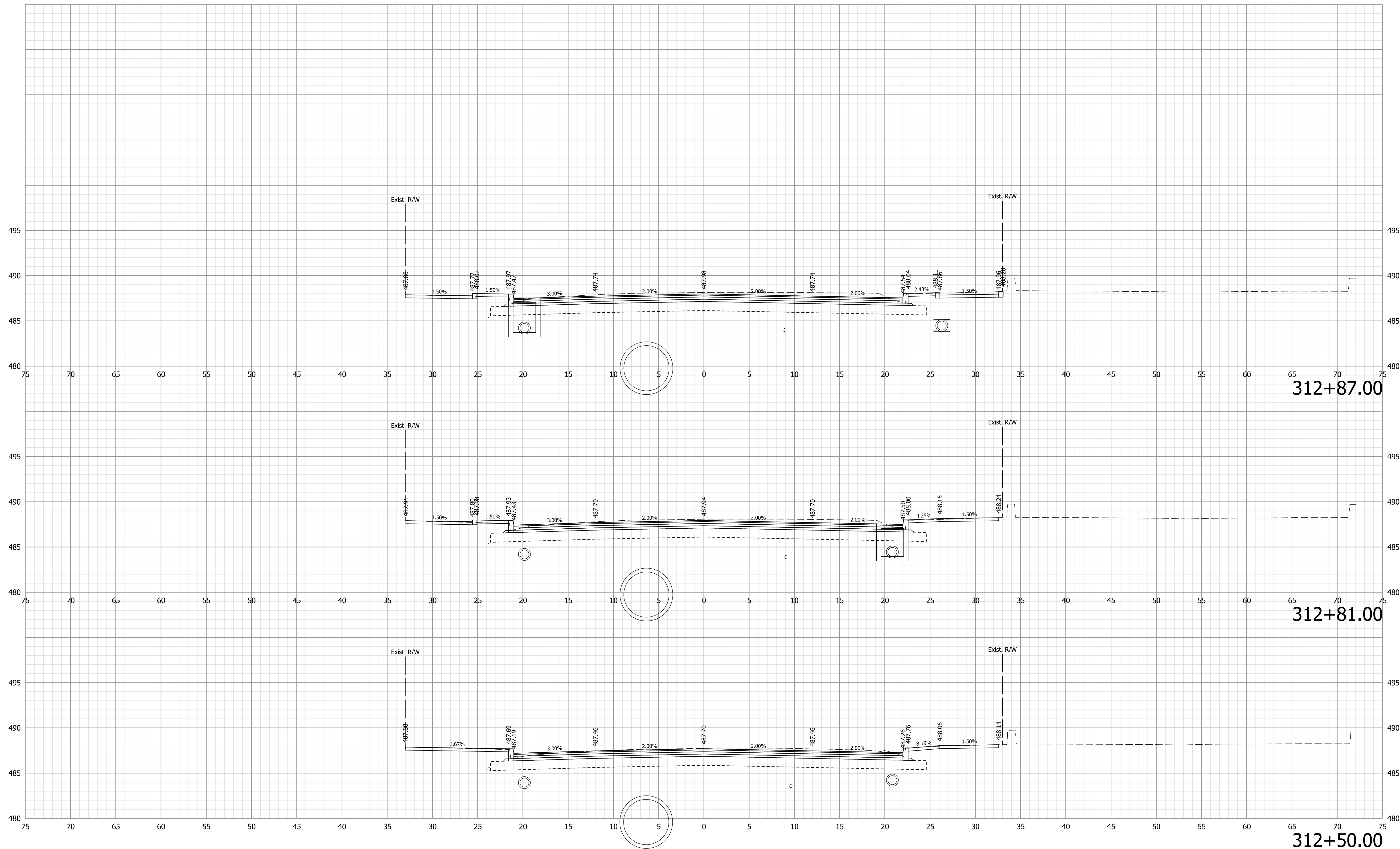

312+87.00

312+81.00

312+50.00

Note:  
 1. All utilities information shall be considered QL-D unless otherwise indicated and is for informational purposes only. The Contractor is responsible for locating and coordinating with utility companies in accordance with the plans and specifications.

**NOT FOR CONSTRUCTION**

RECOMMENDED FOR APPROVAL	DESIGN ENGINEER	6/9/2021	DATE
DESIGNED: WCM	6/9/2021	DRAWN: WCM	6/9/2021
CHECKED: LNB	6/9/2021	CHECKED: LNB	6/9/2021

INDIANA  
 DEPARTMENT OF TRANSPORTATION

CROSS SECTIONS  
 LINE "D"

HORIZONTAL SCALE	BRIDGE FILE
1" = 5'	N/A
VERTICAL SCALE	DESIGNATION
1" = 5'	1900334
SURVEY BOOK	SHEETS
Electronic	72 of 89
CONTRACT	PROJECT
R-42228	1900334

Plot: 6/9/2021 8:00:44 PM



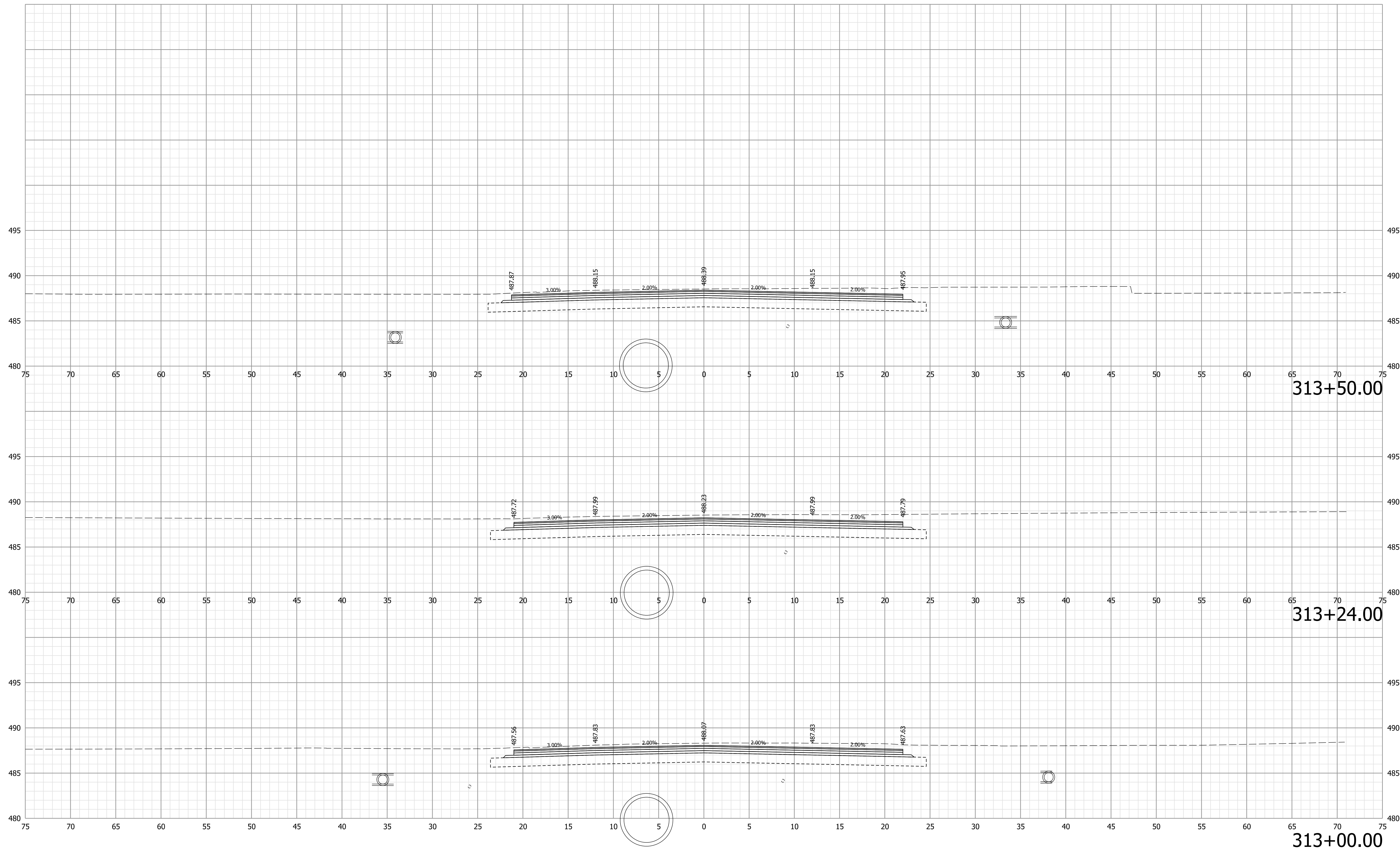

Note:  
 1. All utilities information shall be considered QL-D unless otherwise indicated and is for informational purposes only. The Contractor is responsible for locating and coordinating with utility companies in accordance with the plans and specifications.

**NOT FOR CONSTRUCTION**

RECOMMENDED FOR APPROVAL	DESIGN ENGINEER	6/9/2021	DATE
DESIGNED: WCM	6/9/2021	DRAWN: WCM	6/9/2021
CHECKED: LNB	6/9/2021	CHECKED: LNB	6/9/2021

INDIANA  
DEPARTMENT OF TRANSPORTATION

CROSS SECTIONS  
LINE "D"

HORIZONTAL SCALE	BRIDGE FILE
1" = 5'	N/A
VERTICAL SCALE	DESIGNATION
1" = 5'	1900334
SURVEY BOOK	SHEETS
Electronic	73 of 89
CONTRACT	PROJECT
R-42228	1900334

Plot: 6/9/2021 8:00:50 PM

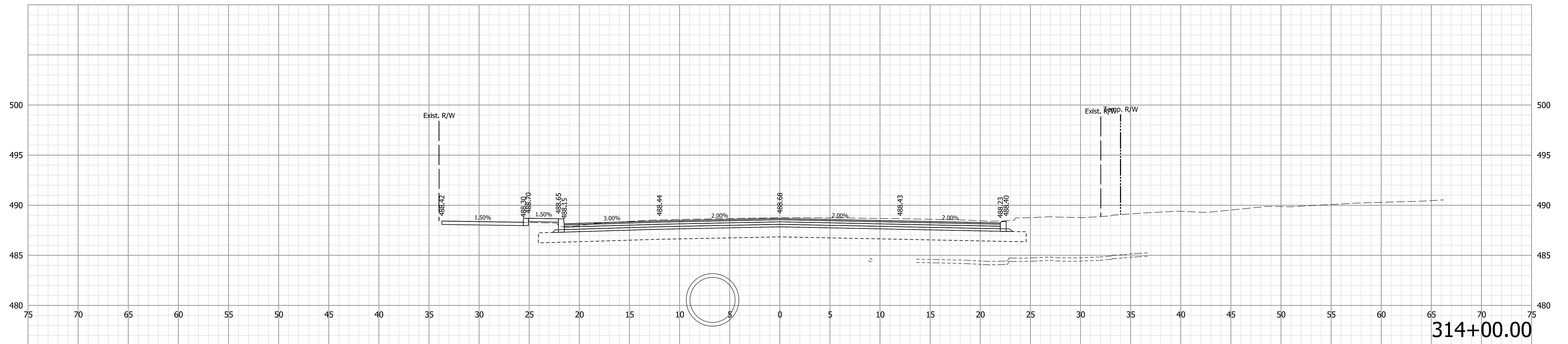

314+00.00

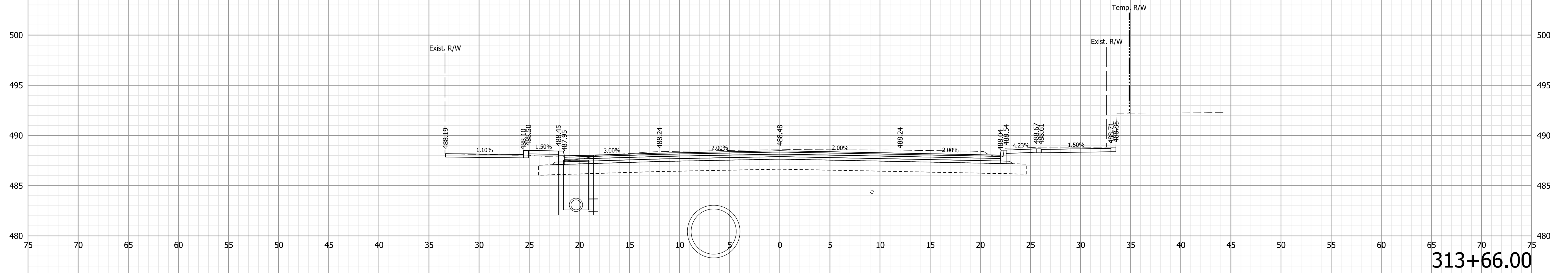

313+66.00

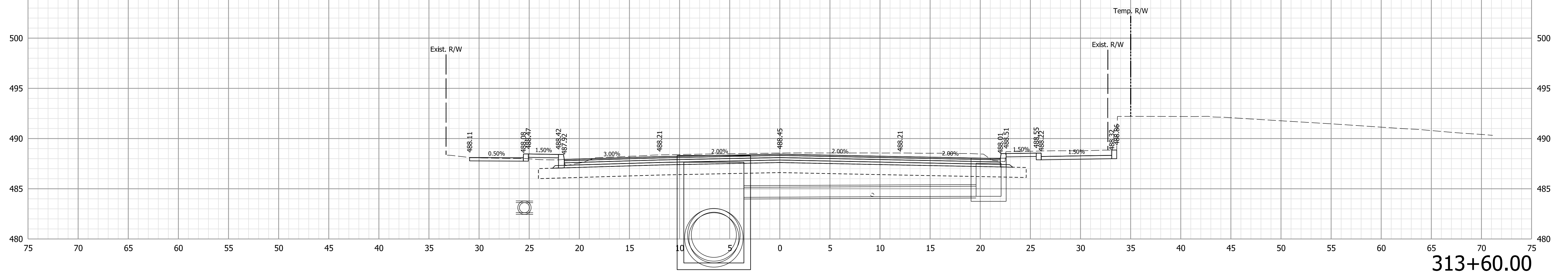

313+60.00

Note:  
 1. All utilities information shall be considered QL-D unless otherwise indicated and is for informational purposes only. The Contractor is responsible for locating and coordinating with utility companies in accordance with the plans and specifications.

NOT FOR CONSTRUCTION

RECOMMENDED FOR APPROVAL	DESIGN ENGINEER	6/9/2021	DATE
DESIGNED: WCM	6/9/2021	DRAWN: WCM	6/9/2021
CHECKED: LNB	6/9/2021	CHECKED: LNB	6/9/2021

INDIANA  
DEPARTMENT OF TRANSPORTATION

CROSS SECTIONS  
LINE "D"

HORIZONTAL SCALE	BRIDGE FILE
1" = 5'	N/A
VERTICAL SCALE	DESIGNATION
1" = 5'	1900334
SURVEY BOOK	SHEETS
Electronic	74 of 89
CONTRACT	PROJECT
R-42228	1900334

Plot: 6/9/2021 8:00:56 PM

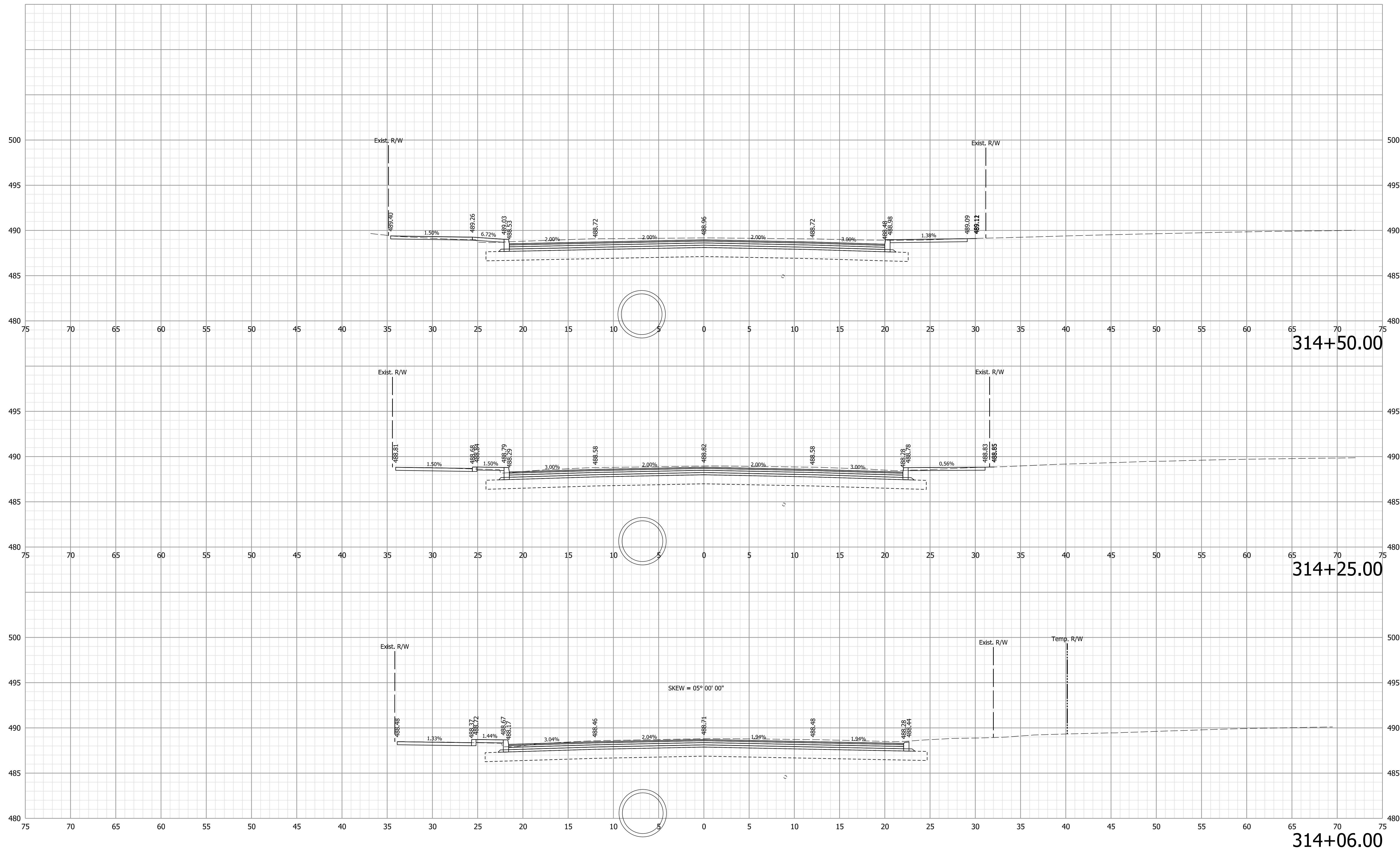

Note:  
 1. All utilities information shall be considered QL-D unless otherwise indicated and is for informational purposes only. The Contractor is responsible for locating and coordinating with utility companies in accordance with the plans and specifications.

**NOT FOR CONSTRUCTION**

RECOMMENDED FOR APPROVAL	DESIGN ENGINEER	6/9/2021	DATE
DESIGNED: WCM	6/9/2021	DRAWN: WCM	6/9/2021
CHECKED: LNB	6/9/2021	CHECKED: LNB	6/9/2021

INDIANA  
 DEPARTMENT OF TRANSPORTATION

CROSS SECTIONS  
 LINE "D"

HORIZONTAL SCALE	BRIDGE FILE
1" = 5'	N/A
VERTICAL SCALE	DESIGNATION
1" = 5'	1900334
SURVEY BOOK	SHEETS
Electronic	75 of 89
CONTRACT	PROJECT
R-42228	1900334

Plot: 6/9/2021 8:01:02 PM

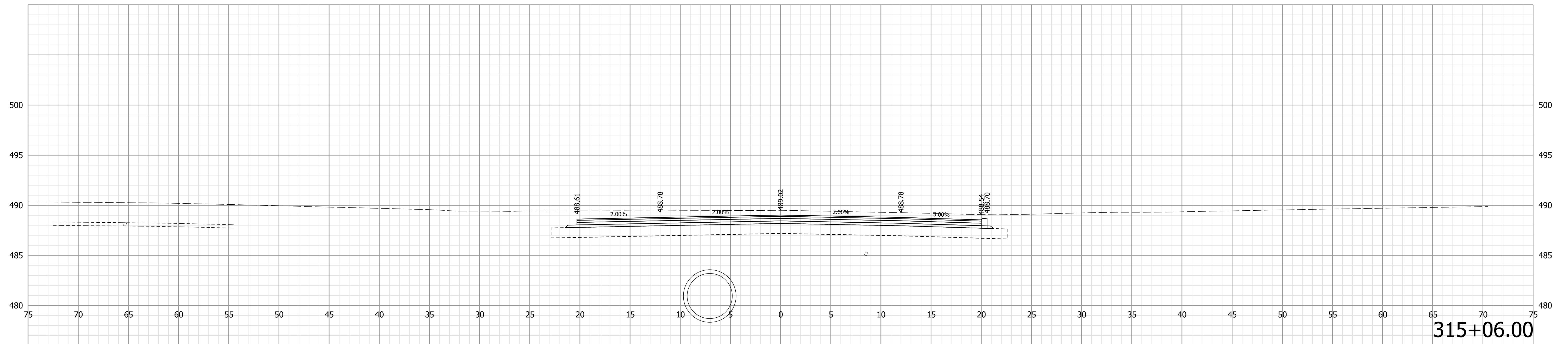

315+06.00

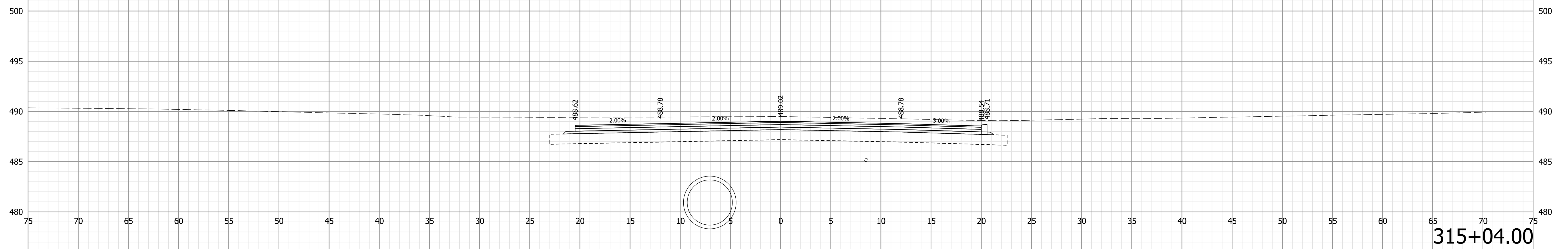

315+04.00

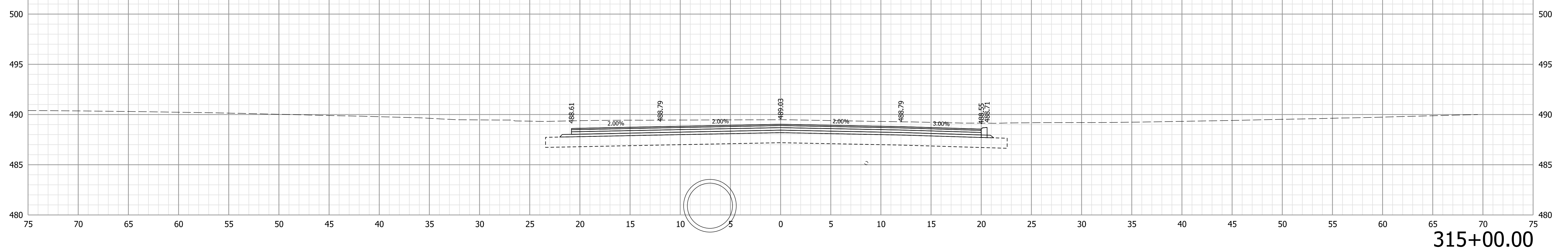

315+00.00

Note:  
 1. All utilities information shall be considered QL-D unless otherwise indicated and is for informational purposes only. The Contractor is responsible for locating and coordinating with utility companies in accordance with the plans and specifications.

NOT FOR CONSTRUCTION

RECOMMENDED FOR APPROVAL	DESIGN ENGINEER	6/9/2021	DATE
DESIGNED: WCM	6/9/2021	DRAWN: WCM	6/9/2021
CHECKED: LNB	6/9/2021	CHECKED: LNB	6/9/2021

INDIANA  
 DEPARTMENT OF TRANSPORTATION

CROSS SECTIONS  
 LINE "D"

HORIZONTAL SCALE	BRIDGE FILE
1" = 5'	N/A
VERTICAL SCALE	DESIGNATION
1" = 5'	1900334
SURVEY BOOK	SHEETS
Electronic	76 of 89
CONTRACT	PROJECT
R-42228	1900334

Plot: 6/9/2021 8:01:07 PM

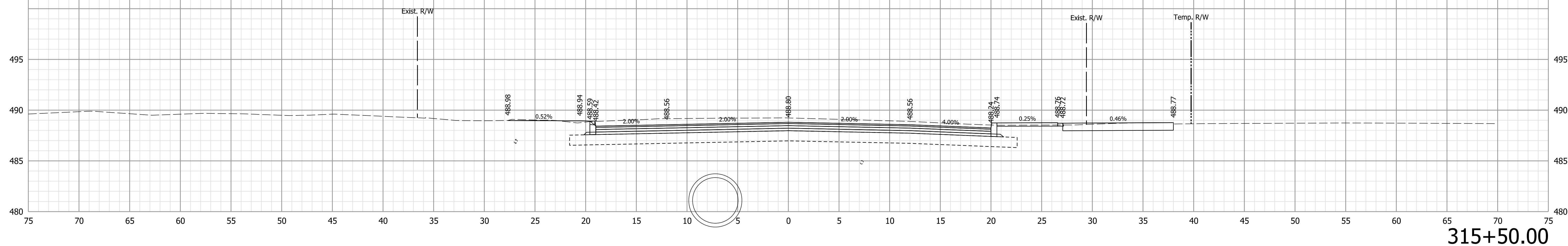
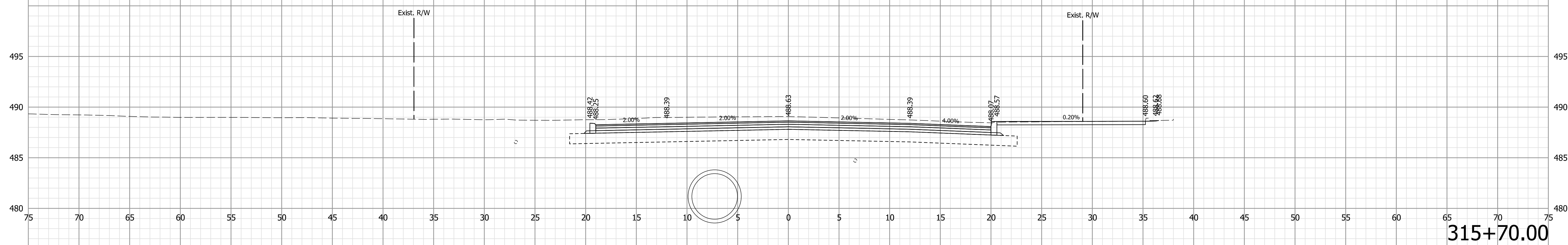
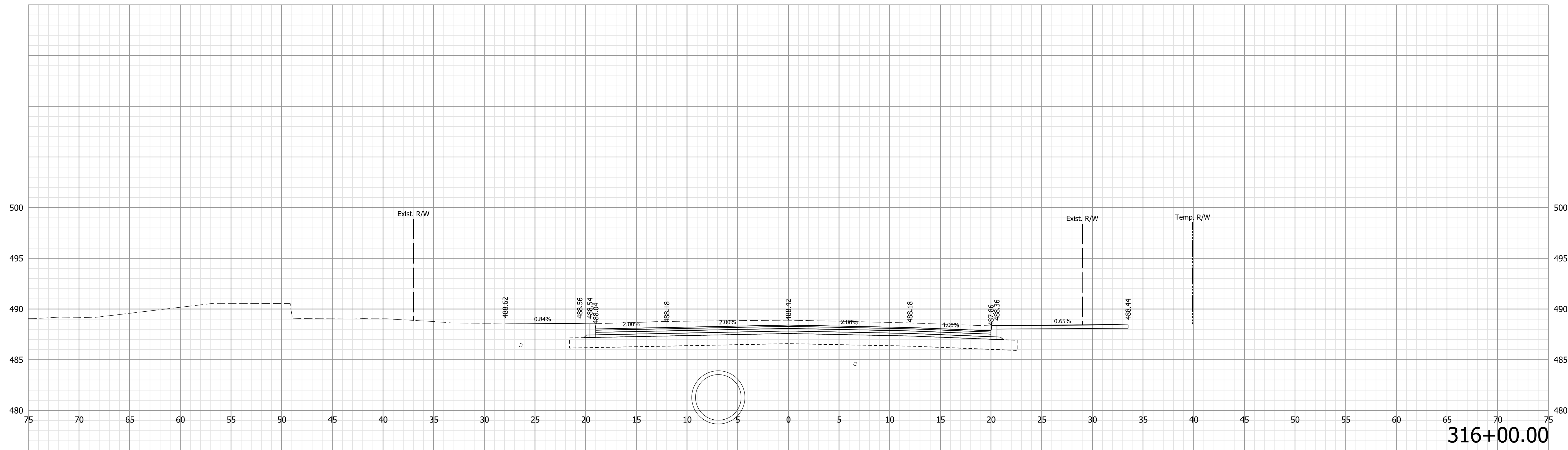

Note:  
 1. All utilities information shall be considered QL-D unless otherwise indicated and is for informational purposes only. The Contractor is responsible for locating and coordinating with utility companies in accordance with the plans and specifications.

NOT FOR CONSTRUCTION

RECOMMENDED FOR APPROVAL	DESIGN ENGINEER	6/9/2021	DATE
DESIGNED: WCM	6/9/2021	DRAWN: WCM	6/9/2021
CHECKED: LNB	6/9/2021	CHECKED: LNB	6/9/2021

INDIANA  
DEPARTMENT OF TRANSPORTATION

CROSS SECTIONS  
LINE "D"

HORIZONTAL SCALE	BRIDGE FILE
1" = 5'	N/A
VERTICAL SCALE	DESIGNATION
1" = 5'	1900334
SURVEY BOOK	SHEETS
Electronic	77 of 89
CONTRACT	PROJECT
R-42228	1900334

Plot: 6/9/2021 8:01:14 PM

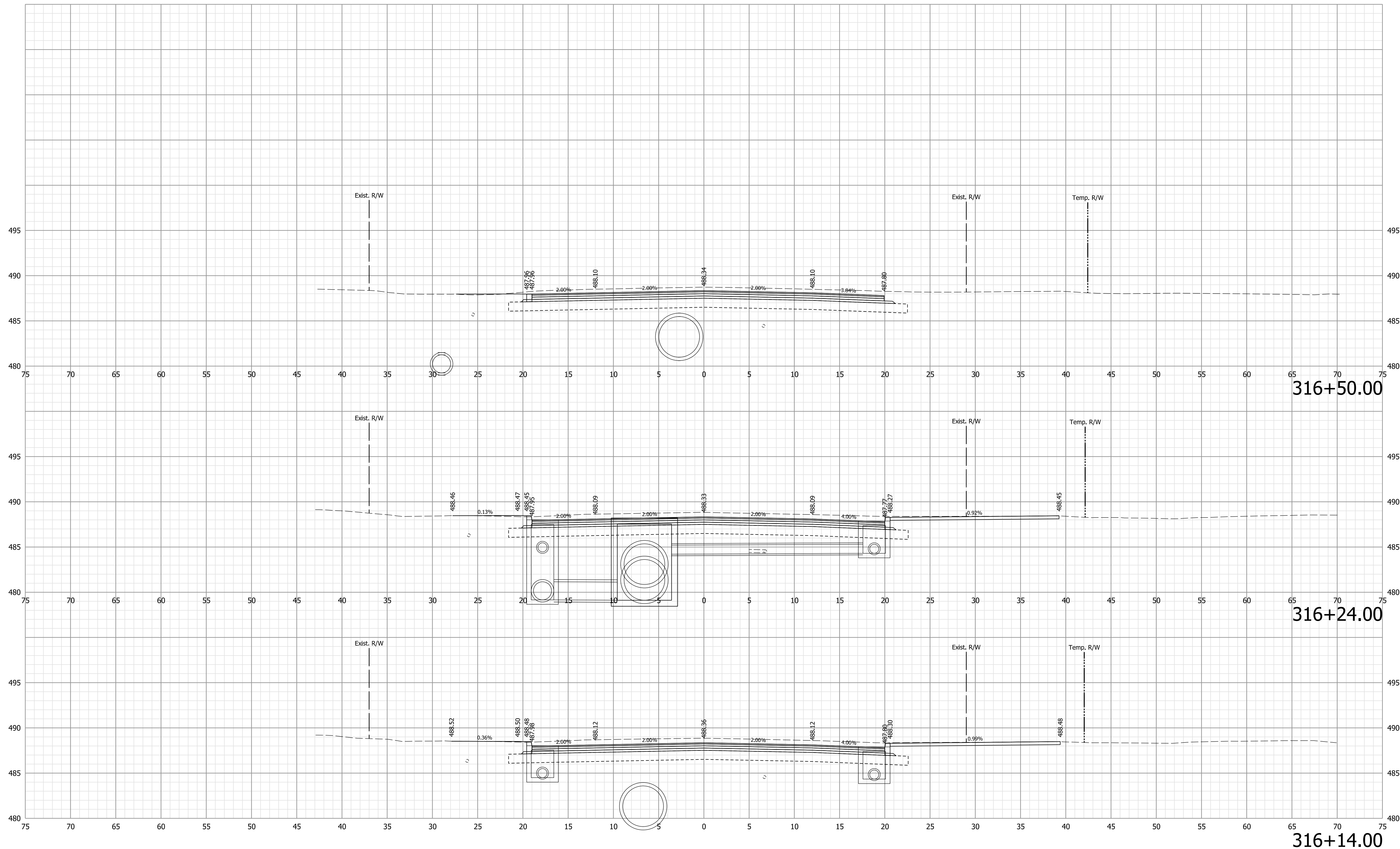

Note:  
 1. All utilities information shall be considered QL-D unless otherwise indicated and is for informational purposes only. The Contractor is responsible for locating and coordinating with utility companies in accordance with the plans and specifications.

**NOT FOR CONSTRUCTION**

RECOMMENDED FOR APPROVAL	DESIGN ENGINEER	6/9/2021	DATE
DESIGNED: WCM	6/9/2021	DRAWN: WCM	6/9/2021
CHECKED: LNB	6/9/2021	CHECKED: LNB	6/9/2021

INDIANA  
 DEPARTMENT OF TRANSPORTATION

CROSS SECTIONS  
 LINE "D"

HORIZONTAL SCALE	BRIDGE FILE
1" = 5'	N/A
VERTICAL SCALE	DESIGNATION
1" = 5'	1900334
SURVEY BOOK	SHEETS
Electronic	78 of 89
CONTRACT	PROJECT
R-42228	1900334

Plot: 6/9/2021 8:01:20 PM

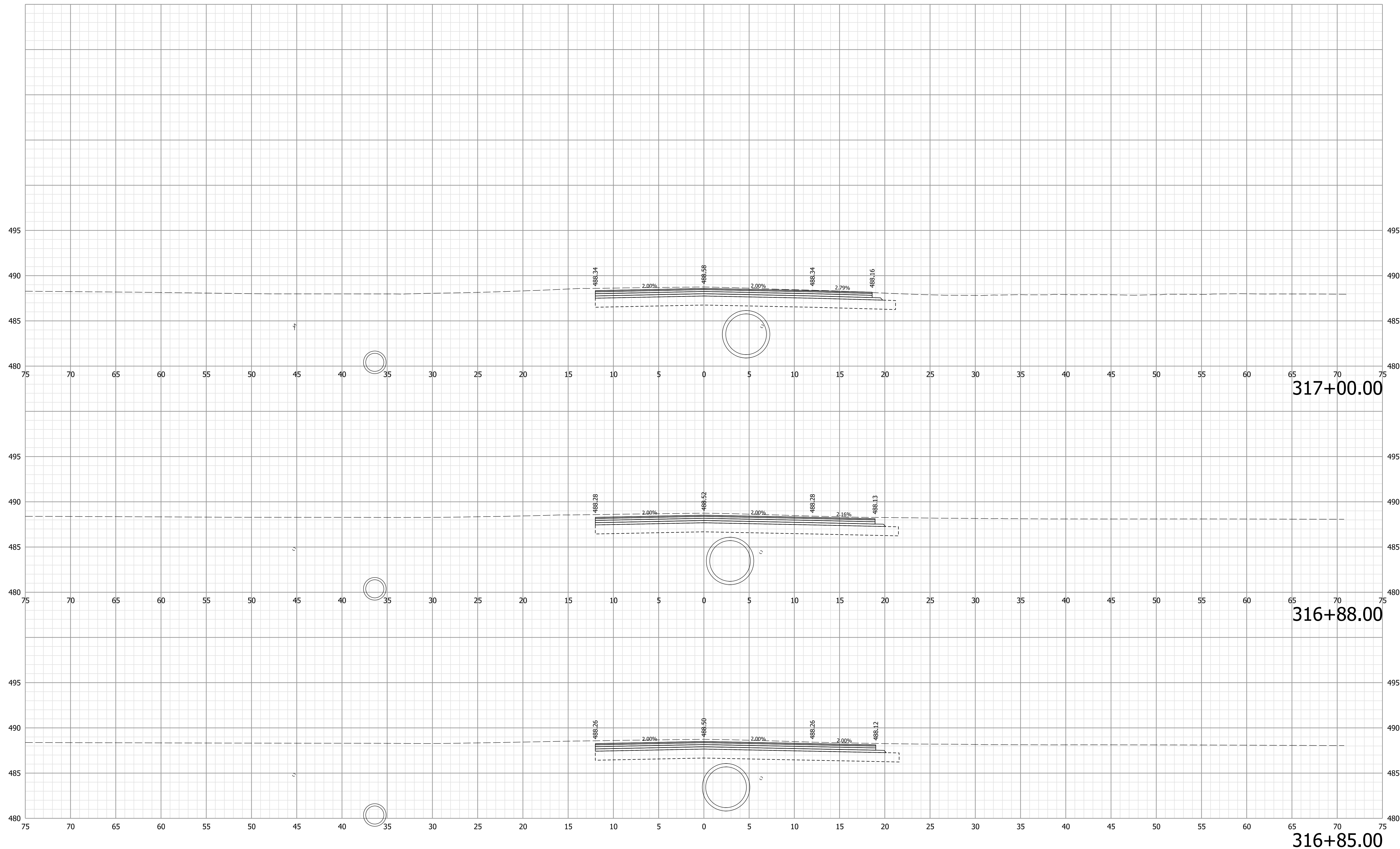

Note:  
 1. All utilities information shall be considered QL-D unless otherwise indicated and is for informational purposes only. The Contractor is responsible for locating and coordinating with utility companies in accordance with the plans and specifications.

**NOT FOR  
 CONSTRUCTION**

RECOMMENDED FOR APPROVAL	DESIGN ENGINEER	6/9/2021	DATE
DESIGNED: WCM	6/9/2021	DRAWN: WCM	6/9/2021
CHECKED: LNB	6/9/2021	CHECKED: LNB	6/9/2021

INDIANA  
 DEPARTMENT OF TRANSPORTATION

CROSS SECTIONS  
 LINE "D"

HORIZONTAL SCALE	BRIDGE FILE
1" = 5'	N/A
VERTICAL SCALE	DESIGNATION
1" = 5'	1900334
SURVEY BOOK	SHEETS
Electronic	79 of 89
CONTRACT	PROJECT
R-42228	1900334

Plot: 6/9/2021 8:01:25 PM

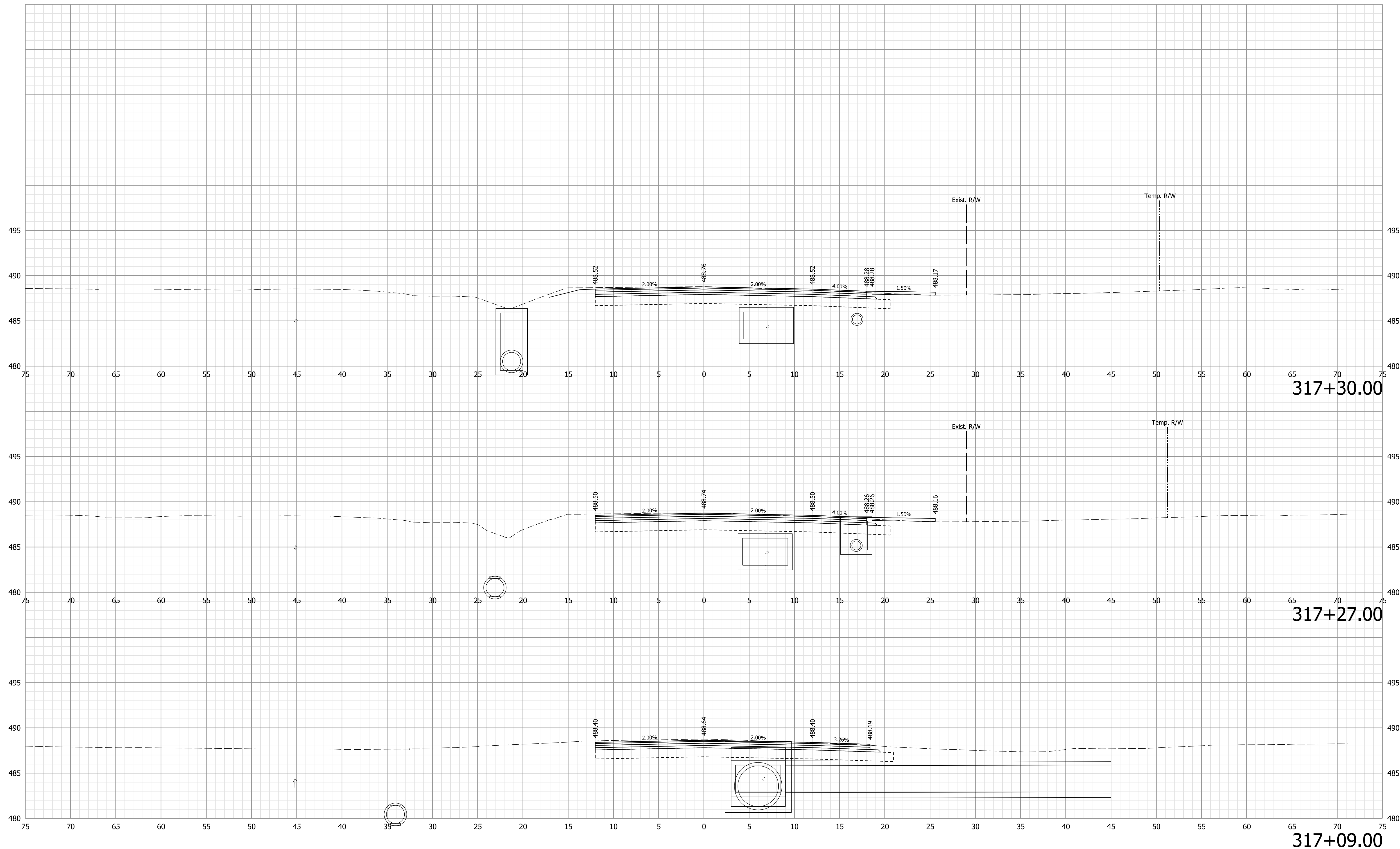

Note:  
 1. All utilities information shall be considered QL-D unless otherwise indicated and is for informational purposes only. The Contractor is responsible for locating and coordinating with utility companies in accordance with the plans and specifications.

**NOT FOR CONSTRUCTION**

RECOMMENDED FOR APPROVAL	DESIGN ENGINEER	6/9/2021	DATE
DESIGNED: WCM	6/9/2021	DRAWN: WCM	6/9/2021
CHECKED: LNB	6/9/2021	CHECKED: LNB	6/9/2021

INDIANA  
DEPARTMENT OF TRANSPORTATION

CROSS SECTIONS  
LINE "D"

HORIZONTAL SCALE	BRIDGE FILE
1" = 5'	N/A
VERTICAL SCALE	DESIGNATION
1" = 5'	1900334
SURVEY BOOK	SHEETS
Electronic	80 of 89
CONTRACT	PROJECT
R-42228	1900334

Plot: 6/9/2021 8:01:31 PM



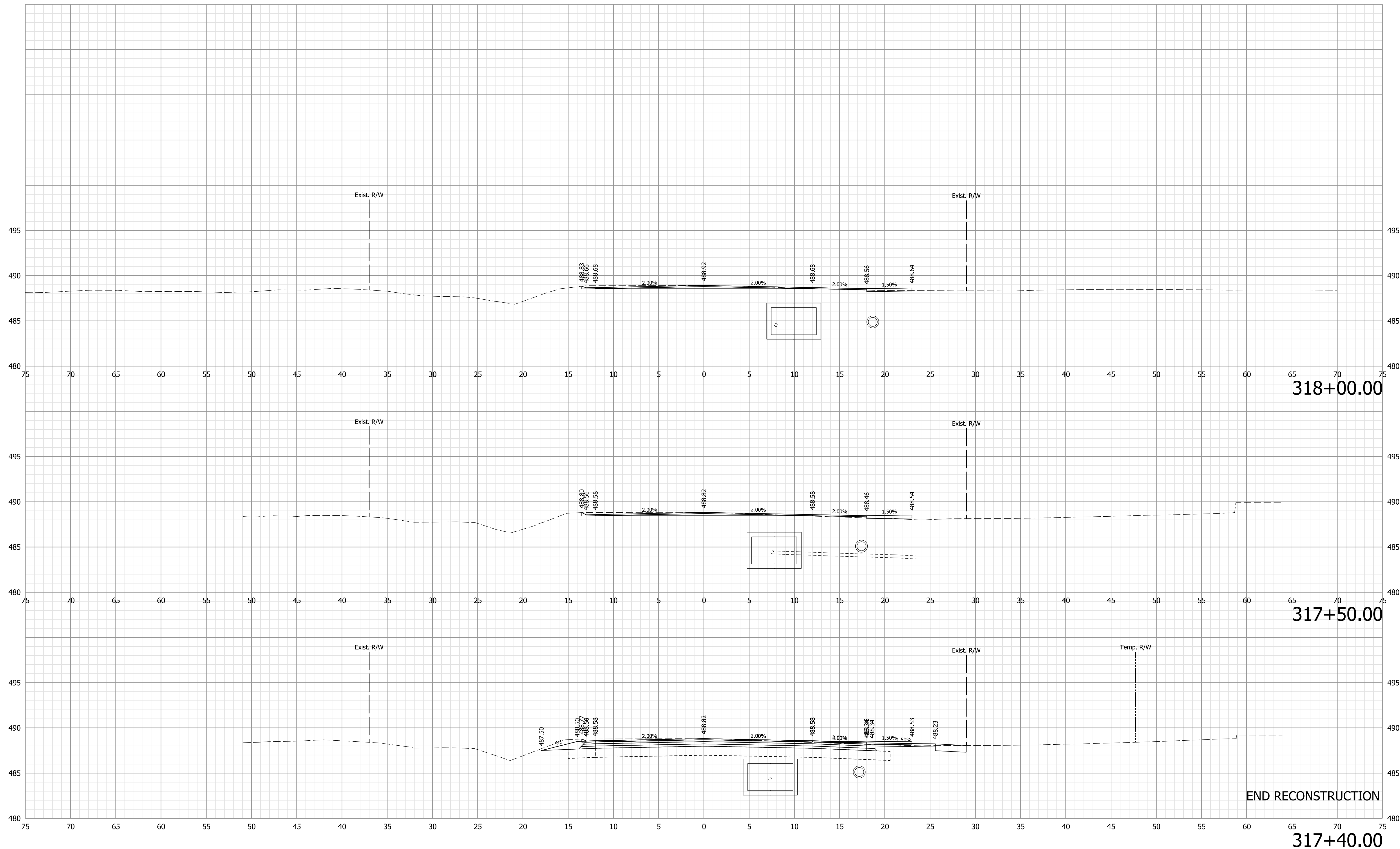

Note:  
 1. All utilities information shall be considered QL-D unless otherwise indicated and is for informational purposes only. The Contractor is responsible for locating and coordinating with utility companies in accordance with the plans and specifications.

**NOT FOR CONSTRUCTION**

RECOMMENDED FOR APPROVAL \_\_\_\_\_ 6/9/2021 DATE  
 DESIGN ENGINEER  
 DESIGNED: WCM 6/9/2021 DRAWN: WCM 6/9/2021  
 CHECKED: LNB 6/9/2021 CHECKED: LNB 6/9/2021

INDIANA  
 DEPARTMENT OF TRANSPORTATION

CROSS SECTIONS  
 LINE "D"

HORIZONTAL SCALE	BRIDGE FILE
1" = 5'	N/A
VERTICAL SCALE	DESIGNATION
1" = 5'	1900334
SURVEY BOOK	SHEETS
Electronic	81 of 89
CONTRACT	PROJECT
R-42228	1900334

Plot: 6/9/2021 8:01:37 PM

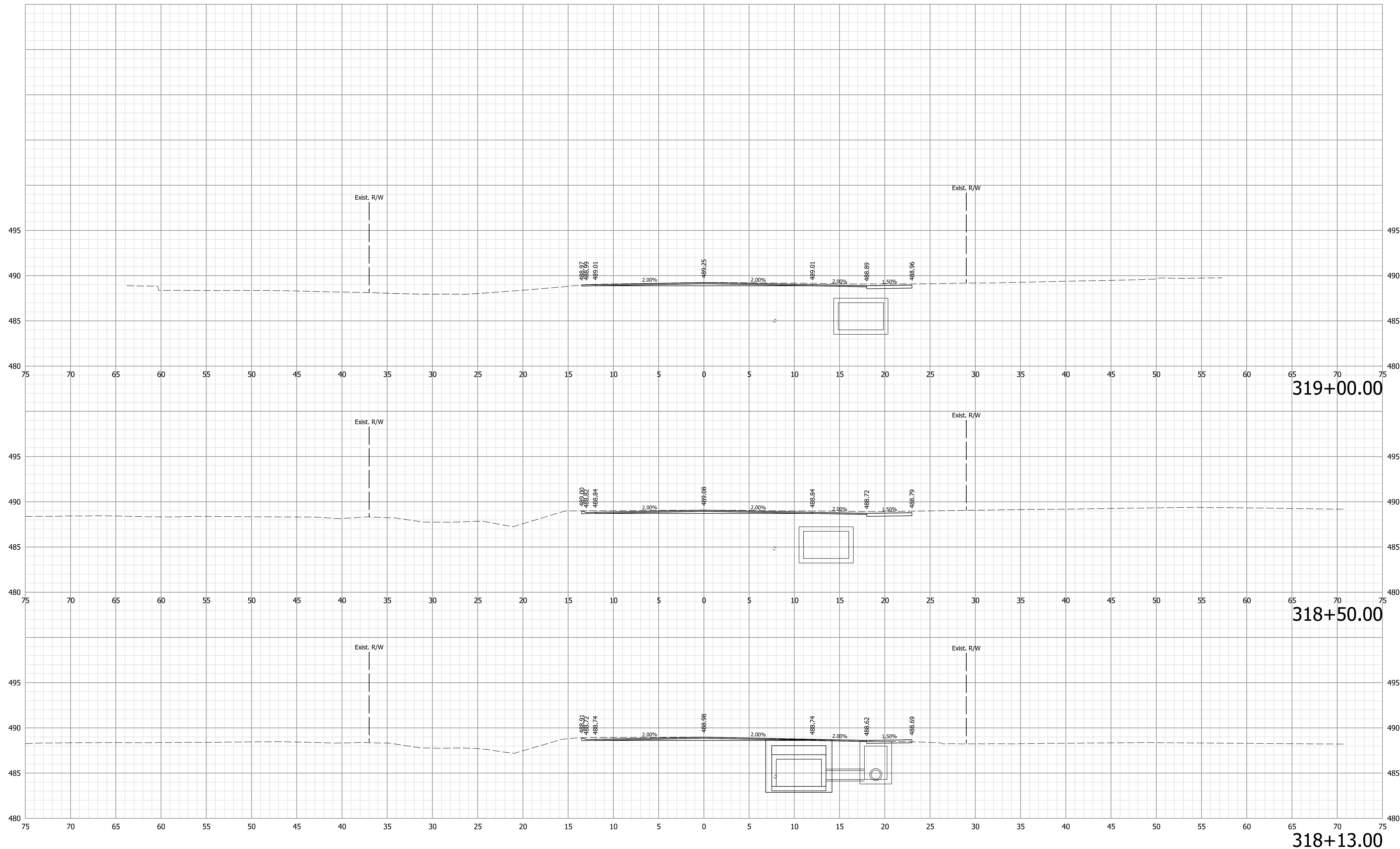

Note:  
 1. All utilities information shall be considered QL-D unless otherwise indicated and is for informational purposes only. The Contractor is responsible for locating and coordinating with utility companies in accordance with the plans and specifications.

**NOT FOR CONSTRUCTION**

RECOMMENDED FOR APPROVAL	DESIGN ENGINEER	6/9/2021	DATE
DESIGNED: WCM	6/9/2021	DRAWN: WCM	6/9/2021
CHECKED: LNB	6/9/2021	CHECKED: LNB	6/9/2021

INDIANA  
DEPARTMENT OF TRANSPORTATION

CROSS SECTIONS  
LINE "D"

HORIZONTAL SCALE	BRIDGE FILE
1" = 5'	N/A
VERTICAL SCALE	DESIGNATION
1" = 5'	1900334
SURVEY BOOK	SHEETS
Electronic	82 of 89
CONTRACT	PROJECT
R-42228	1900334

Plot: 6/9/2021 8:01:42 PM

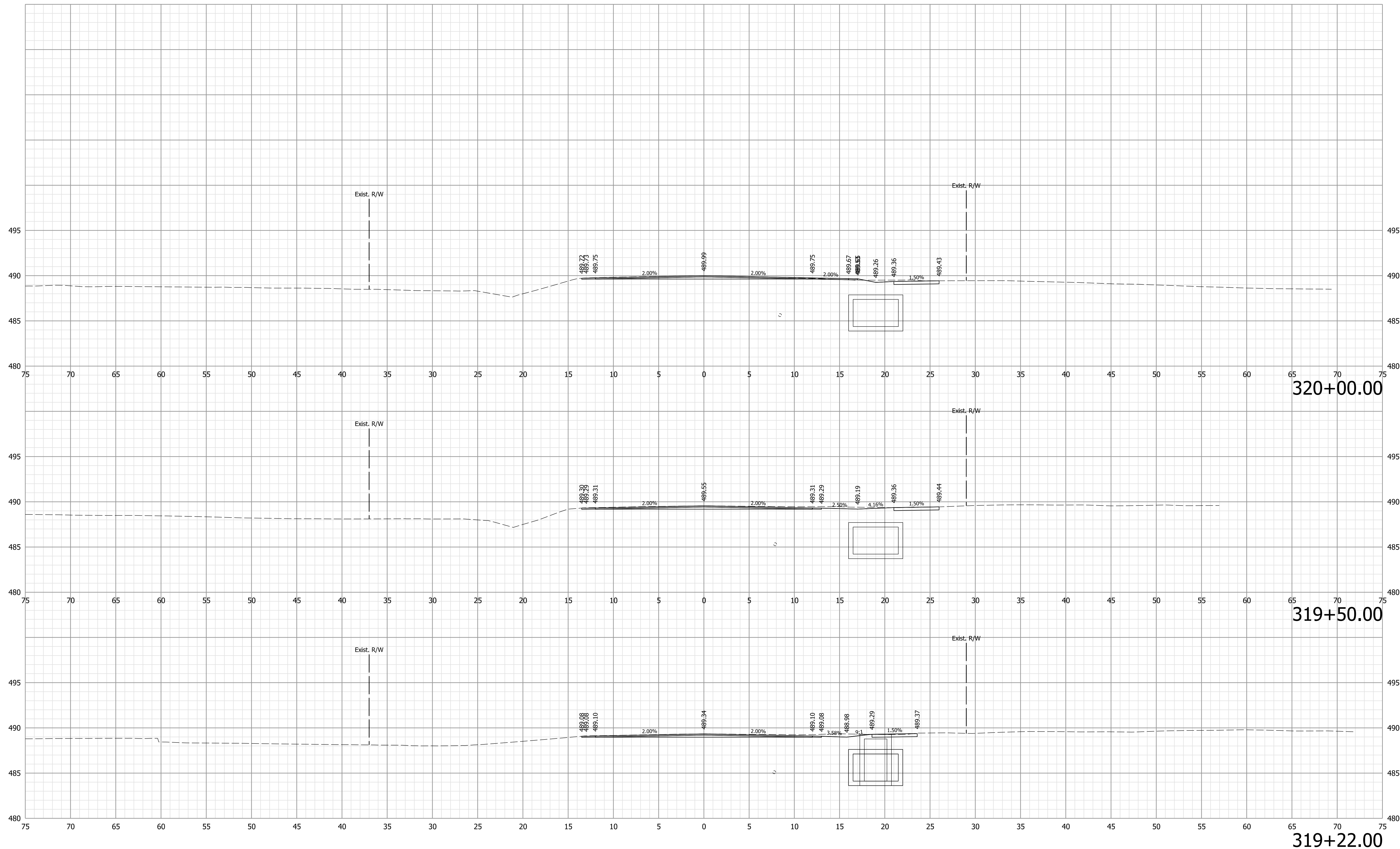

Note:  
 1. All utilities information shall be considered QL-D unless otherwise indicated and is for informational purposes only. The Contractor is responsible for locating and coordinating with utility companies in accordance with the plans and specifications.

**NOT FOR CONSTRUCTION**

RECOMMENDED FOR APPROVAL	DESIGN ENGINEER	6/9/2021	DATE
DESIGNED: WCM	6/9/2021	DRAWN: WCM	6/9/2021
CHECKED: LNB	6/9/2021	CHECKED: LNB	6/9/2021

INDIANA  
DEPARTMENT OF TRANSPORTATION

CROSS SECTIONS  
LINE "D"

HORIZONTAL SCALE	BRIDGE FILE
1" = 5'	N/A
VERTICAL SCALE	DESIGNATION
1" = 5'	1900334
SURVEY BOOK	SHEETS
Electronic	83 of 89
CONTRACT	PROJECT
R-42228	1900334

Plot: 6/9/2021 8:01:46 PM

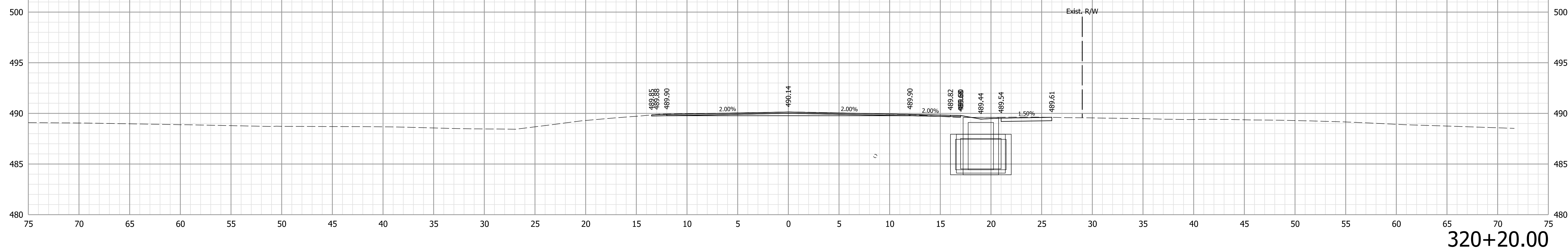
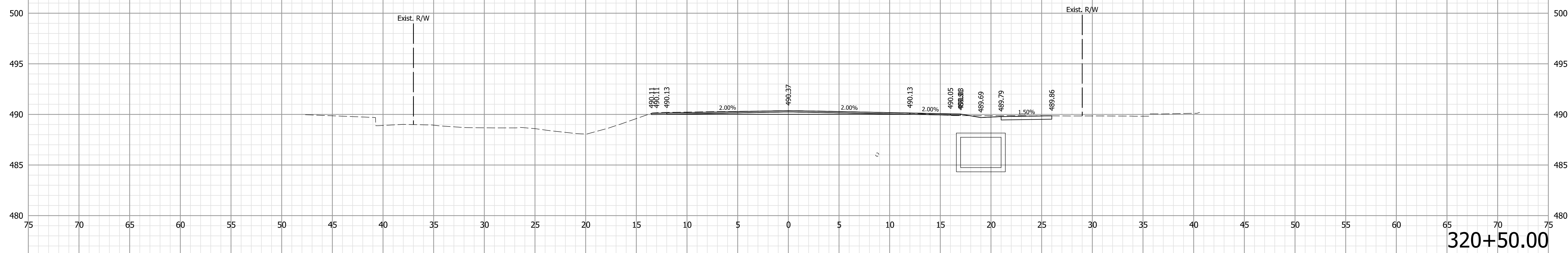
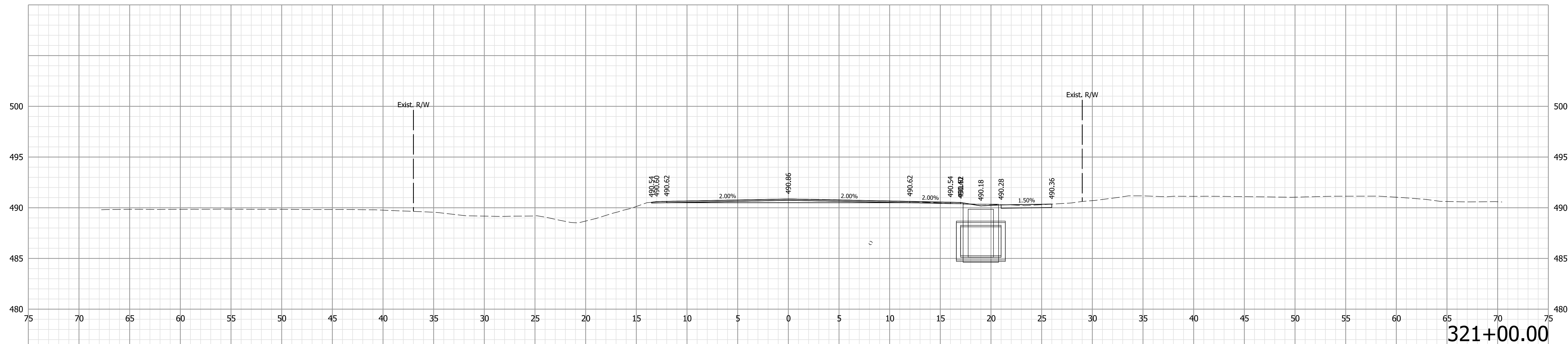

Note:  
 1. All utilities information shall be considered QL-D unless otherwise indicated and is for informational purposes only. The Contractor is responsible for locating and coordinating with utility companies in accordance with the plans and specifications.

**NOT FOR CONSTRUCTION**

RECOMMENDED FOR APPROVAL	DESIGN ENGINEER	6/9/2021	DATE
DESIGNED: WCM	6/9/2021	DRAWN: WCM	6/9/2021
CHECKED: LNB	6/9/2021	CHECKED: LNB	6/9/2021

INDIANA  
DEPARTMENT OF TRANSPORTATION

CROSS SECTIONS  
LINE "D"

HORIZONTAL SCALE	BRIDGE FILE
1" = 5'	N/A
VERTICAL SCALE	DESIGNATION
1" = 5'	1900334
SURVEY BOOK	SHEETS
Electronic	84 of 89
CONTRACT	PROJECT
R-42228	1900334

Plot: 6/9/2021 8:01:54 PM

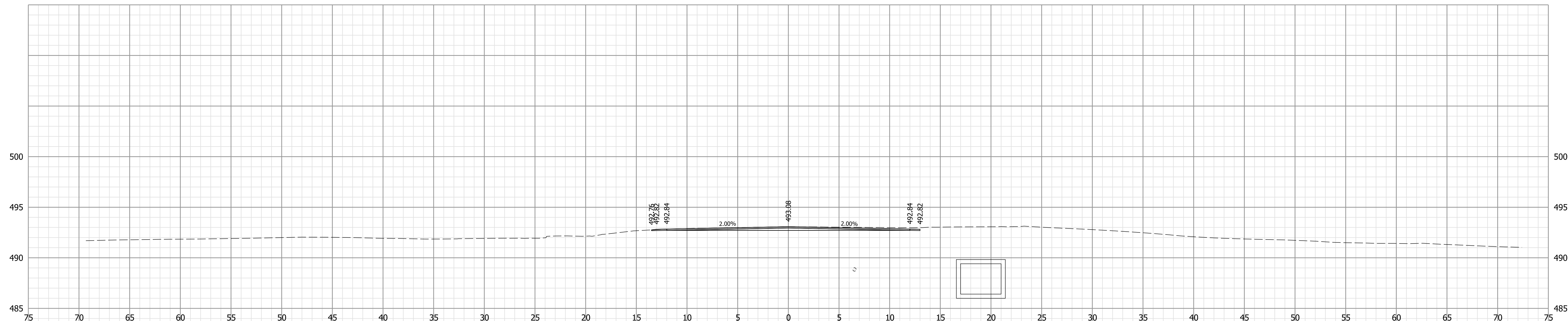

322+50.00

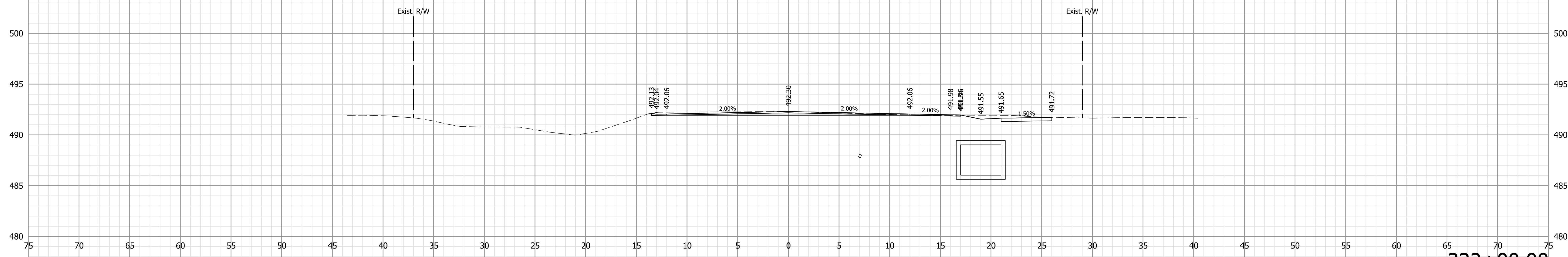

322+00.00

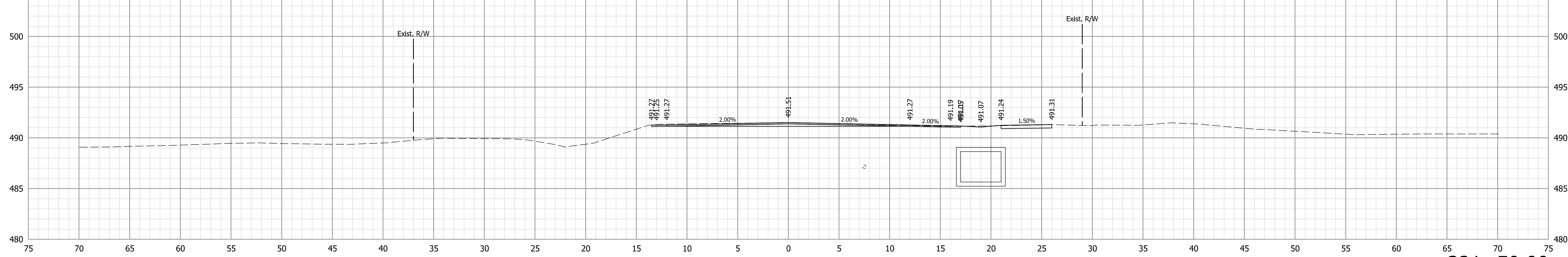

321+50.00

Note:  
1. All utilities information shall be considered QL-D unless otherwise indicated and is for informational purposes only. The Contractor is responsible for locating and coordinating with utility companies in accordance with the plans and specifications.

**NOT FOR CONSTRUCTION**

RECOMMENDED FOR APPROVAL	DESIGN ENGINEER	6/9/2021	DATE
DESIGNED: WCM	6/9/2021	DRAWN: WCM	6/9/2021
CHECKED: LNB	6/9/2021	CHECKED: LNB	6/9/2021

INDIANA  
DEPARTMENT OF TRANSPORTATION

CROSS SECTIONS  
LINE "D"

HORIZONTAL SCALE	BRIDGE FILE
1" = 5'	N/A
VERTICAL SCALE	DESIGNATION
1" = 5'	1900334
SURVEY BOOK	SHEETS
Electronic	85 of 89
CONTRACT	PROJECT
R-42228	1900334

Plot: 6/9/2021 8:01:59 PM

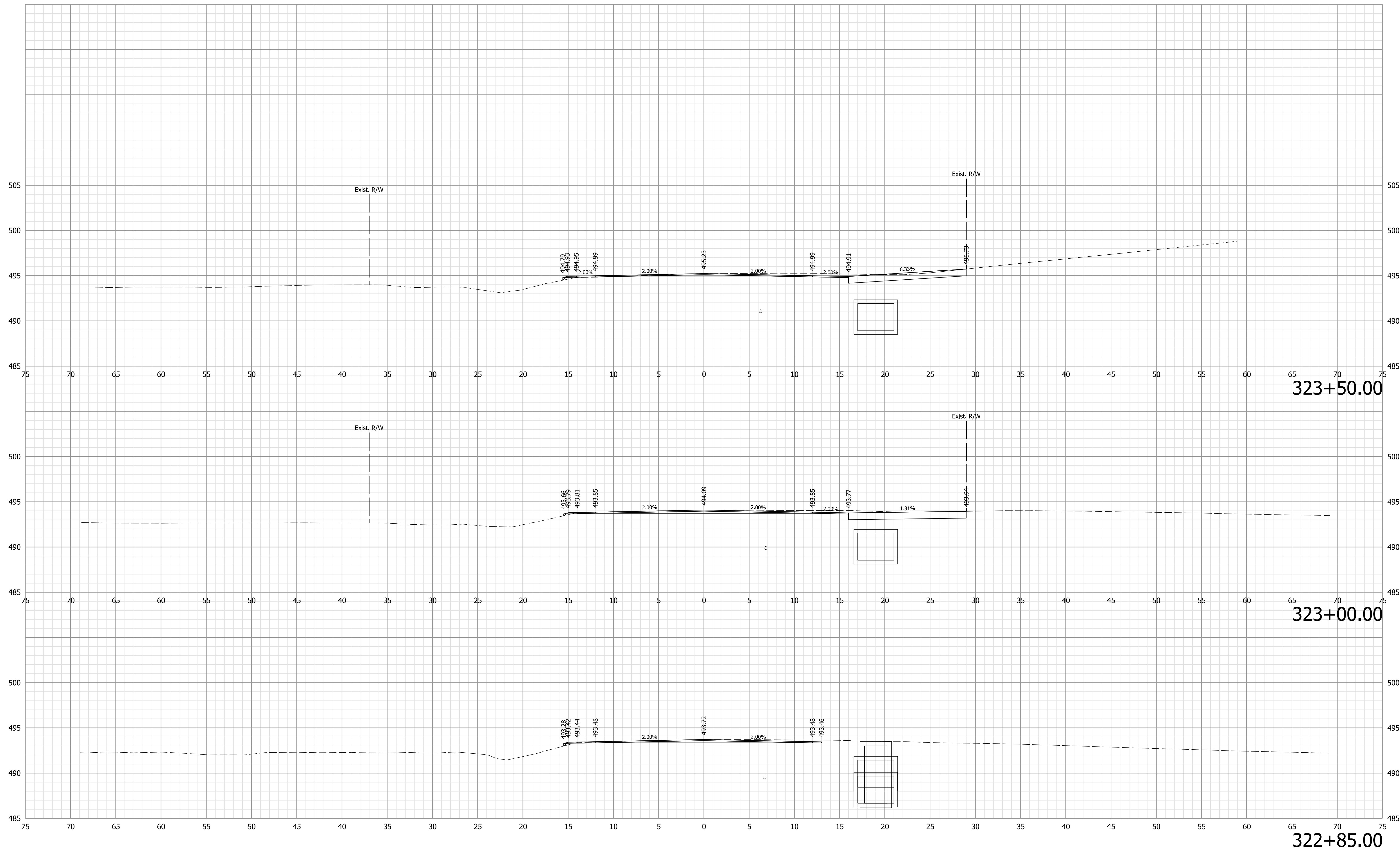

Note:  
 1. All utilities information shall be considered QL-D unless otherwise indicated and is for informational purposes only. The Contractor is responsible for locating and coordinating with utility companies in accordance with the plans and specifications.

**NOT FOR CONSTRUCTION**

RECOMMENDED FOR APPROVAL	DESIGN ENGINEER	6/9/2021	DATE
DESIGNED: WCM	6/9/2021	DRAWN: WCM	6/9/2021
CHECKED: LNB	6/9/2021	CHECKED: LNB	6/9/2021

INDIANA  
DEPARTMENT OF TRANSPORTATION

CROSS SECTIONS  
LINE "D"

HORIZONTAL SCALE	BRIDGE FILE
1" = 5'	N/A
VERTICAL SCALE	DESIGNATION
1" = 5'	1900334
SURVEY BOOK	SHEETS
Electronic	86 of 89
CONTRACT	PROJECT
R-42228	1900334

Plot: 6/9/2021 8:02:05 PM

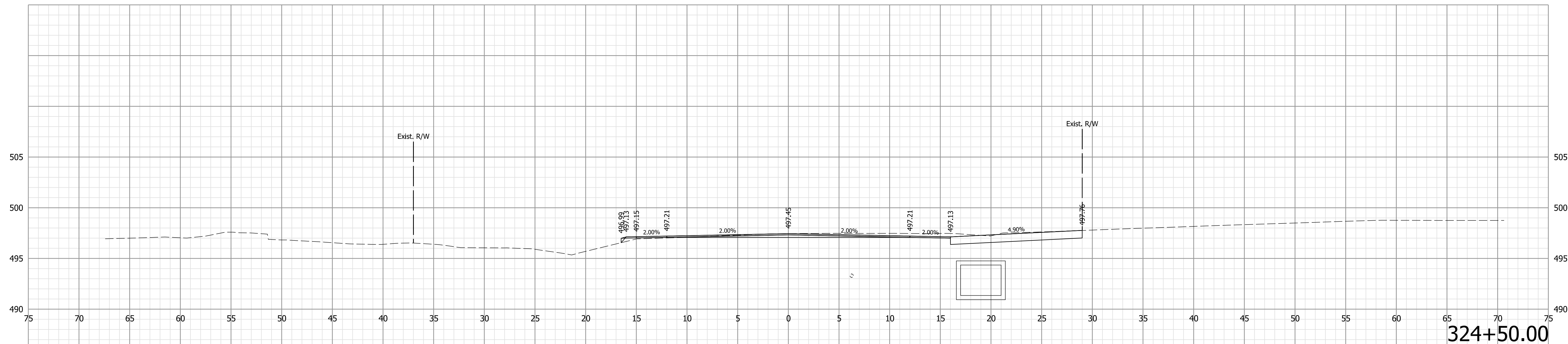

324+50.00

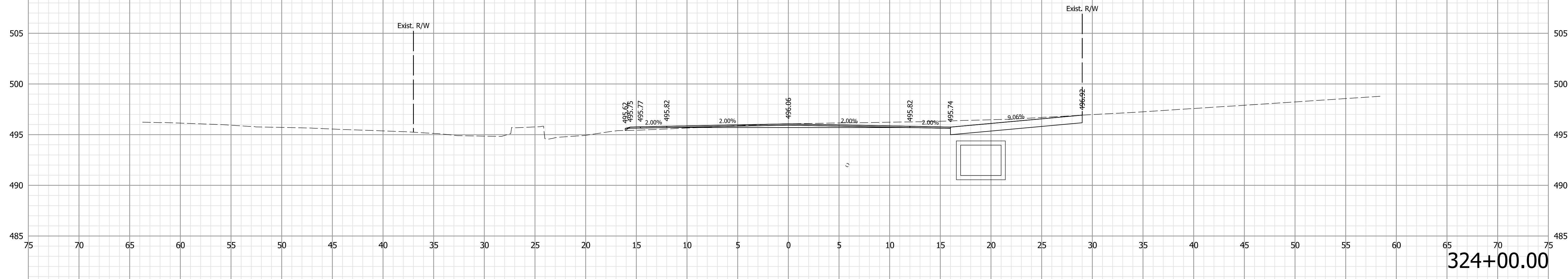

324+00.00

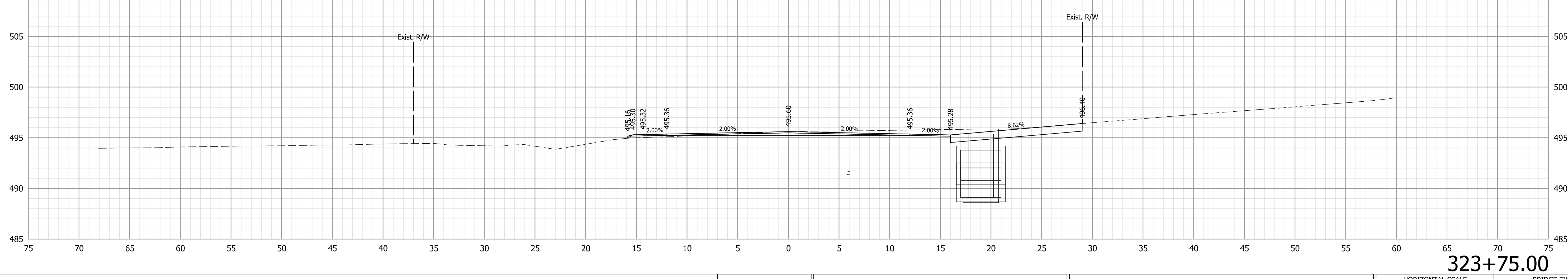

323+75.00

Note:  
1. All utilities information shall be considered QL-D unless otherwise indicated and is for informational purposes only. The Contractor is responsible for locating and coordinating with utility companies in accordance with the plans and specifications.

**NOT FOR CONSTRUCTION**

RECOMMENDED FOR APPROVAL	DESIGN ENGINEER	6/9/2021	DATE
DESIGNED: WCM	6/9/2021	DRAWN: WCM	6/9/2021
CHECKED: LNB	6/9/2021	CHECKED: LNB	6/9/2021

INDIANA  
DEPARTMENT OF TRANSPORTATION

CROSS SECTIONS  
LINE "D"

HORIZONTAL SCALE	BRIDGE FILE
1" = 5'	N/A
VERTICAL SCALE	DESIGNATION
1" = 5'	1900334
SURVEY BOOK	SHEETS
Electronic	87 of 89
CONTRACT	PROJECT
R-42228	1900334

Plot: 6/9/2021 8:02:10 PM

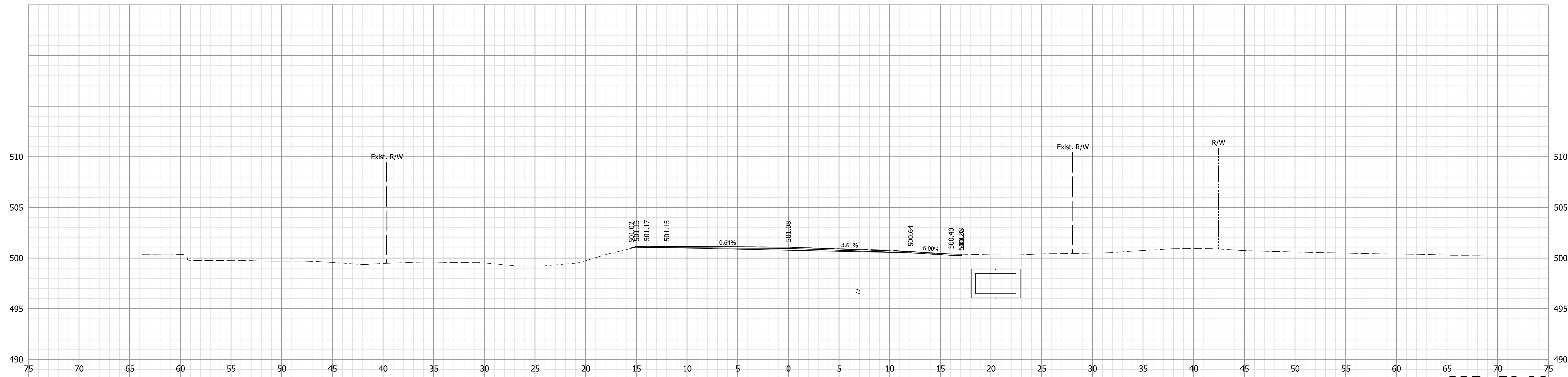

325+50.00

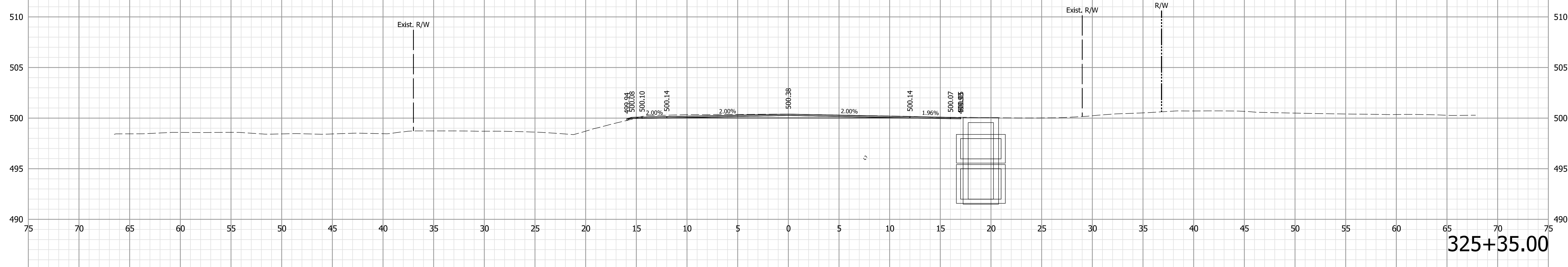

325+35.00

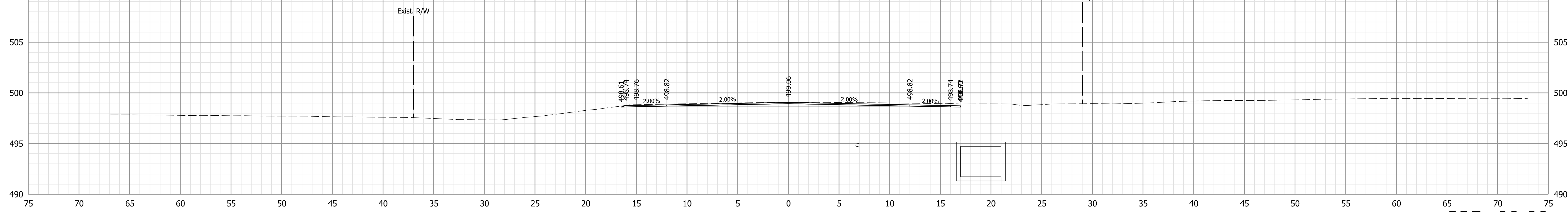

325+00.00

Note:  
 1. All utilities information shall be considered QL-D unless otherwise indicated and is for informational purposes only. The Contractor is responsible for locating and coordinating with utility companies in accordance with the plans and specifications.

NOT FOR CONSTRUCTION

RECOMMENDED FOR APPROVAL	DESIGN ENGINEER	6/9/2021	DATE
DESIGNED: WCM	6/9/2021	DRAWN: WCM	6/9/2021
CHECKED: LNB	6/9/2021	CHECKED: LNB	6/9/2021

INDIANA  
DEPARTMENT OF TRANSPORTATION

CROSS SECTIONS  
LINE "D"

HORIZONTAL SCALE	BRIDGE FILE
1" = 5'	N/A
VERTICAL SCALE	DESIGNATION
1" = 5'	1900334
SURVEY BOOK	SHEETS
Electronic	88 of 89
CONTRACT	PROJECT
R-42228	1900334

Plot: 6/9/2021 8:02:16 PM



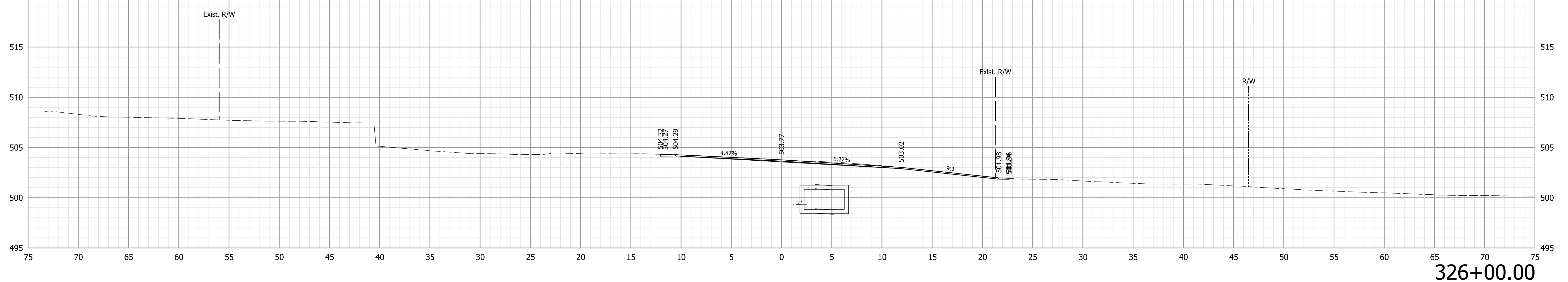
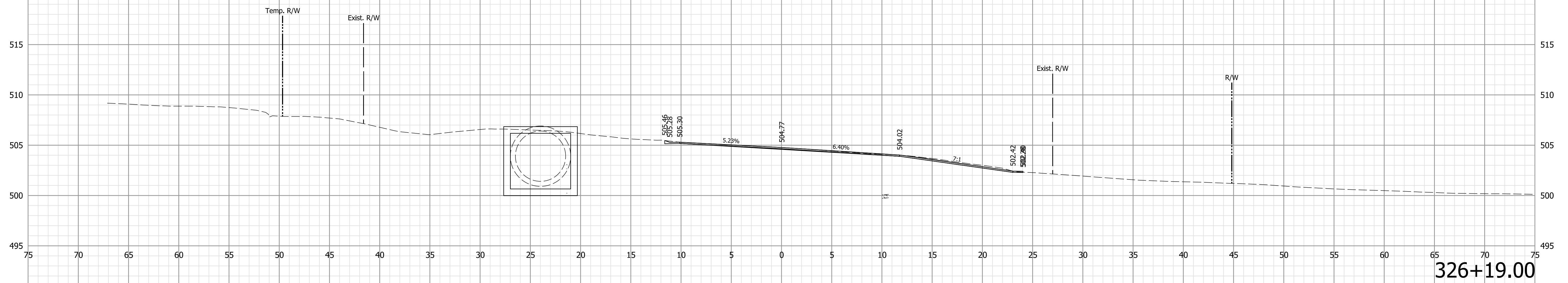
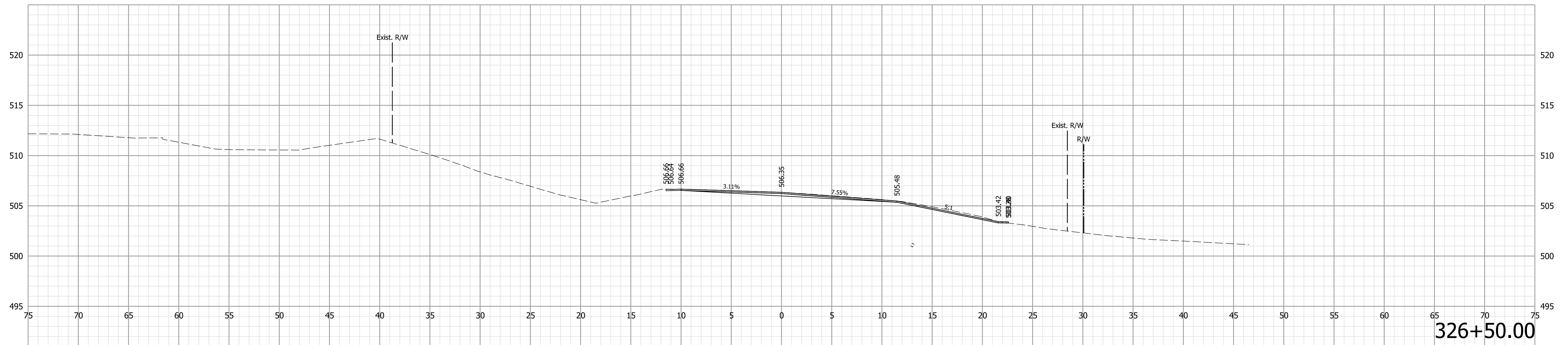

Note:  
 1. All utilities information shall be considered QL-D unless otherwise indicated and is for informational purposes only. The Contractor is responsible for locating and coordinating with utility companies in accordance with the plans and specifications.

**NOT FOR CONSTRUCTION**

RECOMMENDED FOR APPROVAL	DESIGN ENGINEER	6/9/2021	DATE
DESIGNED: WCM	6/9/2021	DRAWN: WCM	6/9/2021
CHECKED: LNB	6/9/2021	CHECKED: LNB	6/9/2021

INDIANA  
DEPARTMENT OF TRANSPORTATION

CROSS SECTIONS  
LINE "D"

HORIZONTAL SCALE	BRIDGE FILE
1" = 5'	N/A
VERTICAL SCALE	DESIGNATION
1" = 5'	1900334
SURVEY BOOK	SHEETS
Electronic	89 of 89
CONTRACT	PROJECT
R-42228	1900334

Plot: 6/9/2021 8:02:21 PM