

PROJECT	DESIGNATION
2001940	2001940
CONTRACT	BRIDGE FILE
B-42732	-

INDIANA DEPARTMENT OF TRANSPORTATION



ROAD PLANS

Small Structure Replacement on S.R. 65

ROUTE: S.R. 65 FROM: RP 41+00.00 TO: RP 41+02.70

PROJECT NO. 2001940 P.E.

PROJECT NO. 2001940 R/W

PROJECT NO. 2001940 CONST.

CULVERT ASSETS	
Culvert Asset ID	Work Type
CV 065-026-41.24	Small Structure Replacement

KIN PROJECT INFORMATION	
DESIGNATION	PROJECT DESCRIPTION
* 2000746	Bridge Deck Overlay over Lagoon Ditch along SR 57, Approximately 2.81 miles S of SR 358
2000762	Bridge Deck Overlay over Little Conger Creek SR 65, Approximately 0.32 miles S of SR 56
2001940	Small Structure Replacement along SR 65, Approximately 6.5 miles S of junction with SR 56

* LEAD DESIGNATION

PROJECT LOCATION: S.R. 65 over an unnamed tributary of Indian Creek, 6.5 miles south of junction with S.R. 56 in Militia Donation 121, T1S, R10W in Washington Township, Gibson County, Indiana

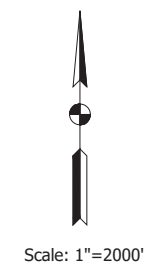
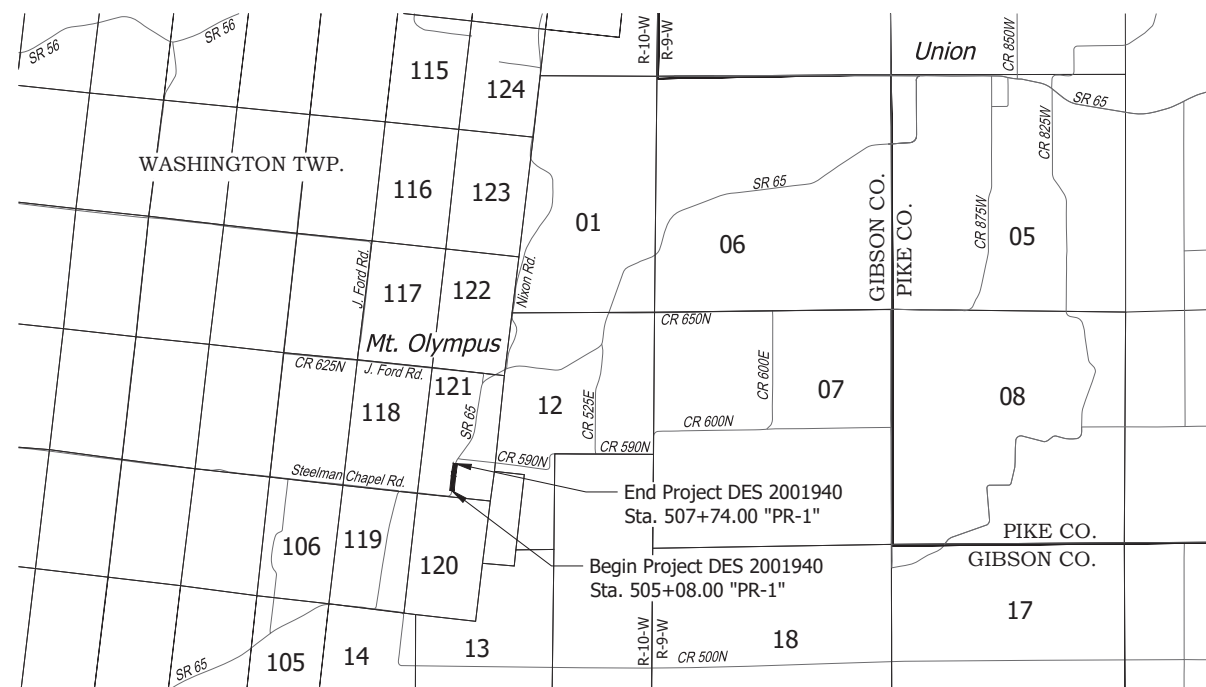

LOCATION MAP
Township, Washington
County, Gibson
State, Indiana

TRAFFIC DATA		
A.A.D.T. (2024)		681 V.P.D.
A.A.D.T. (2044)		831 V.P.D.
D.H.V. (2044)		75 V.P.H.
DIRECTIONAL DISTRIBUTION		63/37 %
TRUCKS		5% A.A.D.T. 16% D.H.V.
DESIGN DATA		
DESIGN SPEED		45 M.P.H.
PROJECT DESIGN CRITERIA		3R (Non-Freeway)
FUNCTIONAL CLASSIFICATION		State Collector
RURAL/URBAN		Rural
TERRAIN		Level
ACCESS CONTROL		None

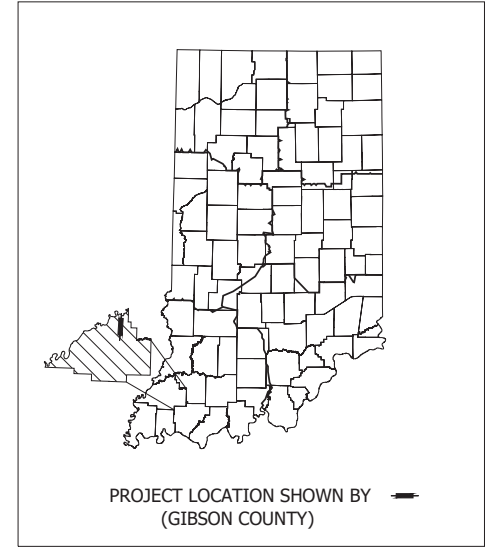

BRIDGE LENGTH:	N/A	MI.
ROADWAY LENGTH:	0.050	MI.
TOTAL LENGTH:	0.050	MI.
MAX. GRADE:	1.717	%
H.U.C.	05120209080050	

LATITUDE: 38° 26' 26" N LONGITUDE: 87° 28' 45" W

FFC Plans
04/10/2024

INDIANA DEPARTMENT OF TRANSPORTATION
STANDARD SPECIFICATIONS DATED 2024
TO BE USED WITH THESE PLANS

BRIDGE FILE	
-	
DESIGNATION	
2001940	
SHEETS	
SURVEY BOOK	1 of 23
ELECTRONIC	
CONTRACT	PROJECT
B-42732	2001940

Plans Prepared By:



PLANS PREPARED BY:	LOCHMUELLER GROUP, INC. 6200 Vogel Road, Evansville, IN 47715	(812) 479-6200 PHONE NUMBER
CERTIFIED BY:		DATE
APPROVED FOR LETTING:	INDIANA DEPARTMENT OF TRANSPORTATION	DATE

Date: Apr 04, 2024, 11:57am User Name: eobson File: X:\Production\Files\2021\121-003\194-00\CAD\Misc\DWG\Title.dwg

Preliminary Design Plans

UTILITIES

WATER

PIKE-GIBSON WATER, INC.
PO Box 126
Oakland City, IN 47660
Contact: Kevin Stilwell
Phone: (812) 749 - 4916
Email: Kevin.Stilwell@pgwi.onmicrosoft.com

COMMUNICATIONS

FRONTIER
8001 West Jefferson Blvd.
Fort Wayne, IN 46804
Contact: Scott Shields
Phone: (812) 634 - 0335
Email: Scott.d.shields@ftr.com



GENERAL NOTES

** REPRESENTS GENERAL NOTES REQUIRED

INDEX

SHEET NO.	DRAWINGS INDEX
1	TITLE
2	INDEX
3-5	TYPICAL CROSS SECTIONS
6	PLAT NO. 1
7	GEOMETRIC TIE-UP SHEET
8	BENCHMARK & REFERENCE BOXES
9	MAINTENANCE OF TRAFFIC
10	PLAN AND PROFILE SHEET (LINE "PR-1")
11-14	EROSION/SEDIMENT CONTROL PLAN & DETAILS
15	STRUCTURE DETAILS
16	PAVEMENT MARKINGS AND SIGNS
17-18	MISCELLANEOUS TABLES
19	APPROACH & STRUCTURE DATA TABLES
20-23	CROSS SECTIONS

REVISIONS

SHEET NO.	DATE	REVISED

Date: Apr 04, 2024, 11:57am User Name: bobson
File: X:\Production\Misc\2021\121-003\1P4-00\1\CAD\Misc\DWG\Index.dwg

RECOMMENDED FOR APPROVAL _____	DESIGN ENGINEER _____ DATE: --/--
DESIGNED: SMW	DRAWN: ERO
CHECKED: JAW	CHECKED: SMW

INDIANA
DEPARTMENT OF TRANSPORTATION

INDEX SHEET

HORIZONTAL SCALE No Scale	BRIDGE FILE N/A
VERTICAL SCALE No Scale	DESIGNATION 2001940
SURVEY BOOK N/A	SHEETS 2 of 23
CONTRACT B-42732	PROJECT 2001940

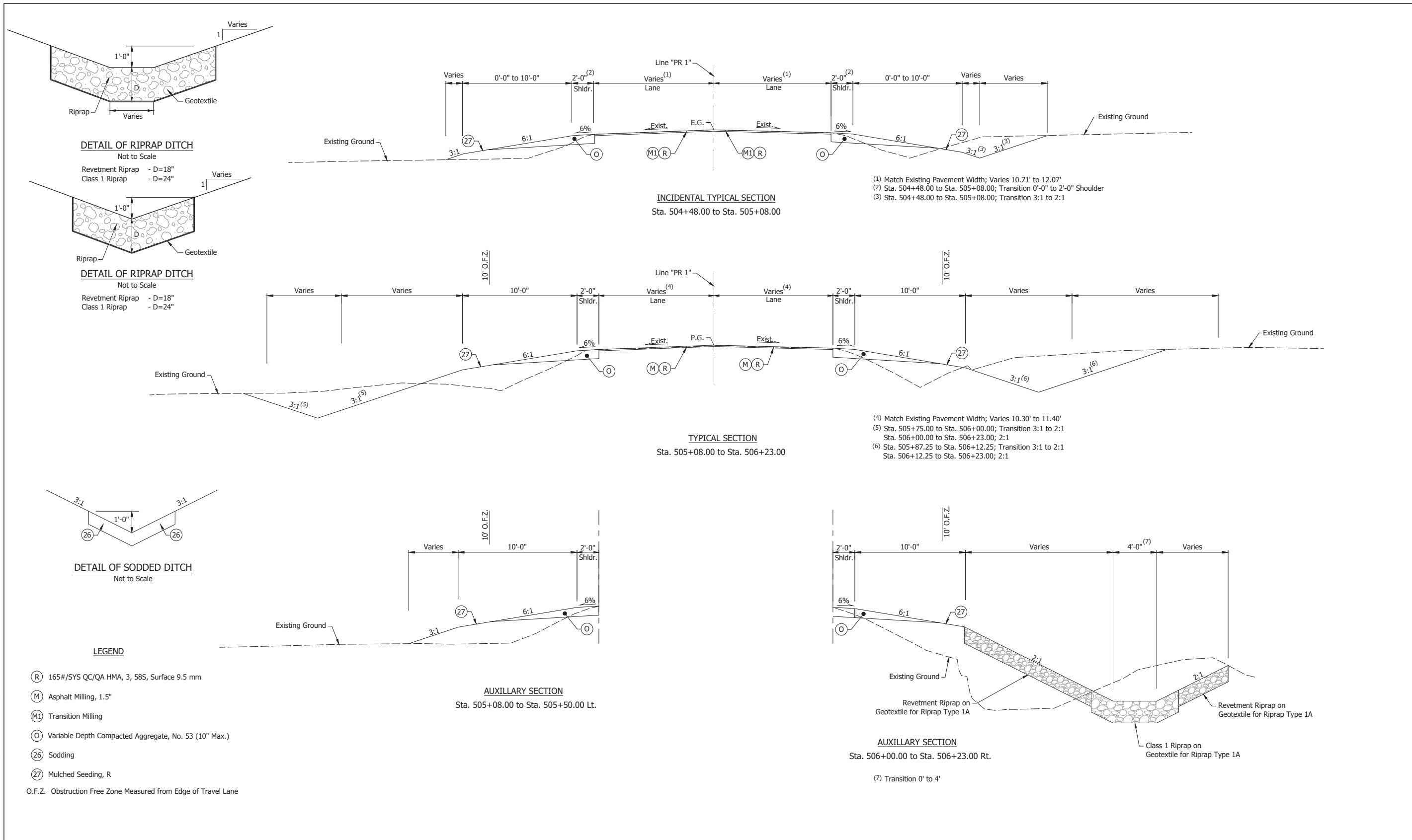

Note:
1) Cross Slope Varies to Match Existing.

RECOMMENDED FOR APPROVAL	DESIGN ENGINEER	DATE
DESIGNED: SMW	DRAWN: ERO	
CHECKED: JAW	CHECKED: SMW	

INDIANA
DEPARTMENT OF TRANSPORTATION

TYPICAL CROSS SECTIONS
LINE "PR-1"

HORIZONTAL SCALE	BRIDGE FILE
1/4" = 1'	-
VERTICAL SCALE	DESIGNATION
-	2001940
SURVEY BOOK	SHEET
	3 of 23
CONTRACT	PROJECT
B-42732	2001940

Date: Apr 04, 2024, 11:58am User Name: eobson
File: X:\Production\Files\2021\121-003\1P4-00\CD\Misc\DWG\Typical Section SR 65.dwg

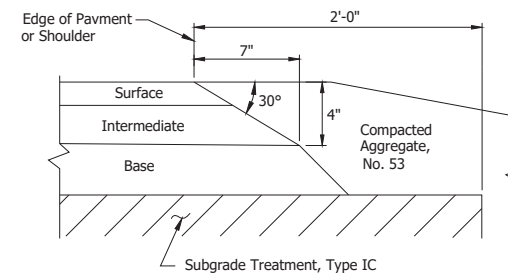
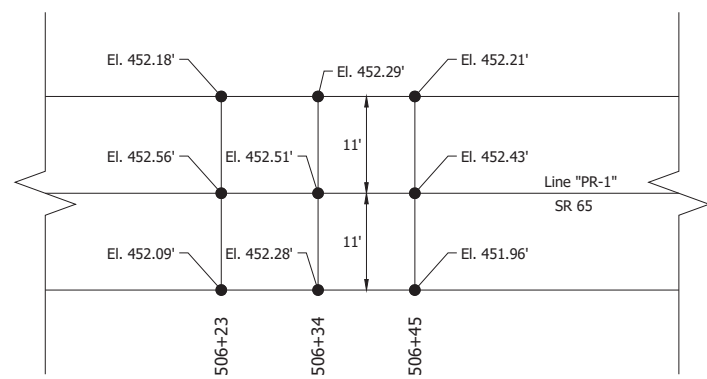
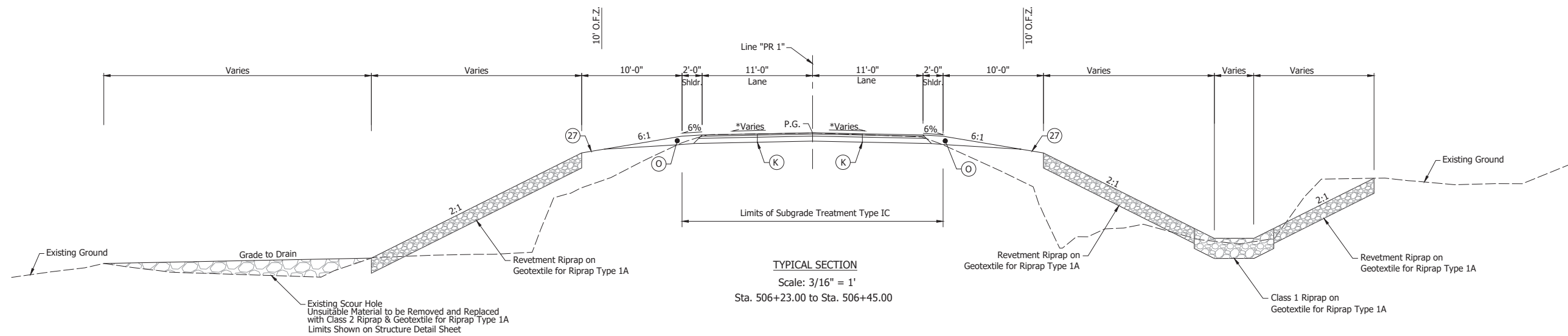

- LEGEND**
- (K) Full Depth HMA
165#/SYS QC/QA HMA, 3, 58S, Surface, 9.5 mm on
275#/SYS QC/QA HMA, 3, 58S, Intermediate, 19.0 mm on
660#/SYS QC/QA HMA, 3, 58S, Base, 25.0 mm on
Subgrade Treatment Type 2B
 - (O) Variable Depth Compacted Aggregate, No. 53 (10" Max.)
 - (27) Mulched Seeding, R
- O.F.Z. Obstruction Free Zone Measured from Edge of Travel Lane

Date: Apr 04, 2024, 11:58am User Name: wolson
File: X:\Production\Misc\20211217-0033\PA-02-CAD\Misc\DWG\Typical Section SR 65.dwg

RECOMMENDED FOR APPROVAL _____	DESIGN ENGINEER _____	DATE: ____/____/____	INDIANA DEPARTMENT OF TRANSPORTATION	HORIZONTAL SCALE As Shown	BRIDGE FILE -
DESIGNED: _____ SMW	DRAWN: _____ ERO			VERTICAL SCALE -	DESIGNATION 2001940
CHECKED: _____ JAW	CHECKED: _____ SMW		TYPICAL CROSS SECTIONS LINE "PR-1"	SURVEY BOOK	SHEET 4 of 23
				CONTRACT B-42732	PROJECT 2001940

Date: Apr 04, 2024, 11:58am User Name: eobson
File: X:\Production\112121\1121-0031\1121-0031\1121-0031\1121-0031\1121-0031\1121-0031\1121-0031\MiscDWG\Typical Section SR 65.dwg

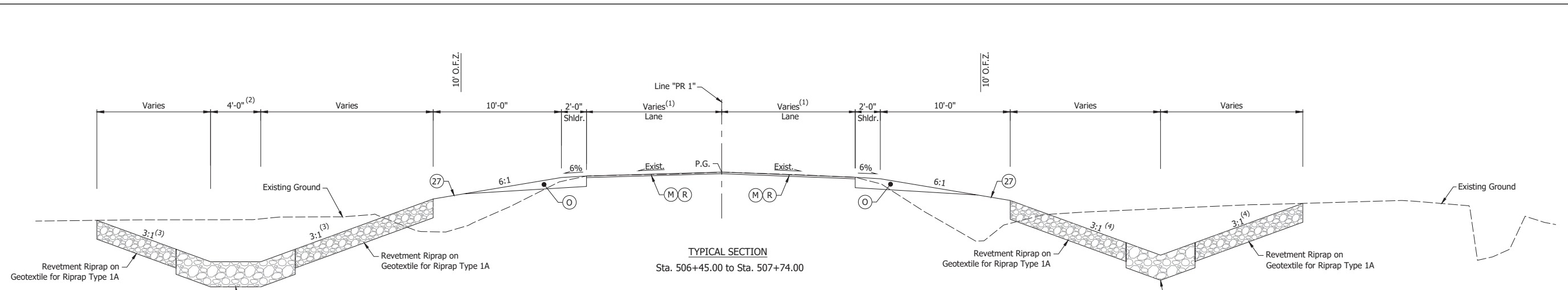

TYPICAL SECTION
Sta. 506+45.00 to Sta. 507+74.00

- (1) Match Existing Pavement Width; Varies 10.59' to 11.15'
- (2) Sta. 506+45.00 to Sta. 507+00.00; 4'-0"
- Sta. 507+00.00 to Sta. 507+25.00; Transition 4'-0" to 0'-0"
- (3) Sta. 506+45.00 to Sta. 506+79.00; Transition 2:1 to 3:1
- Sta. 506+79.00 to Sta. 507+74.00; 3:1
- (4) Sta. 506+45.00 to Sta. 506+81.00; Transition 2:1 to 3:1
- Sta. 506+81.00 to Sta. 507+74.00; 3:1

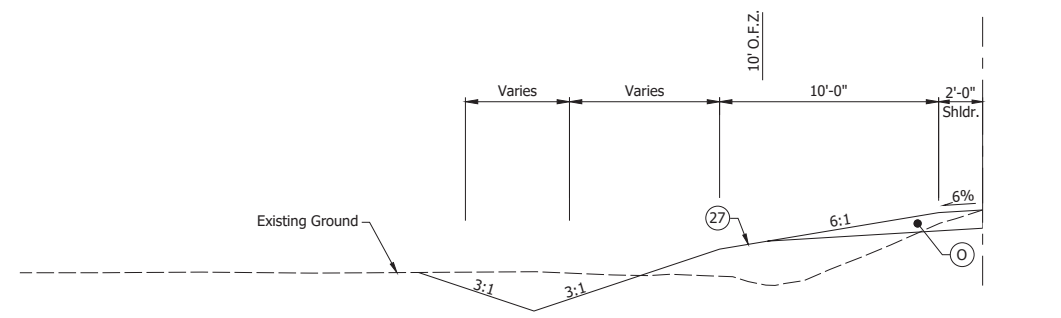

AUXILLARY DITCH SECTION
Sta. 507+25.00 to Sta. 507+74.00 Lt.

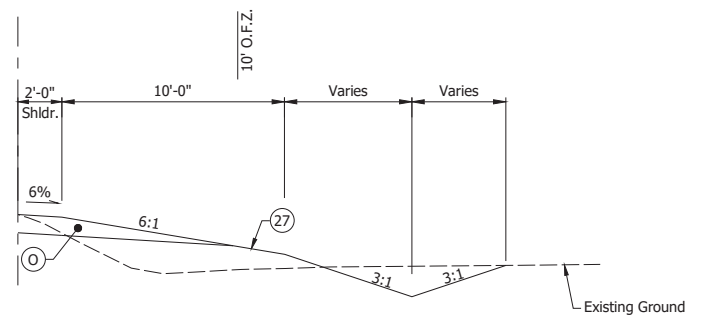

AUXILLARY SECTION
Sta. 506+91.00 to Sta. 506+23.00 Rt.

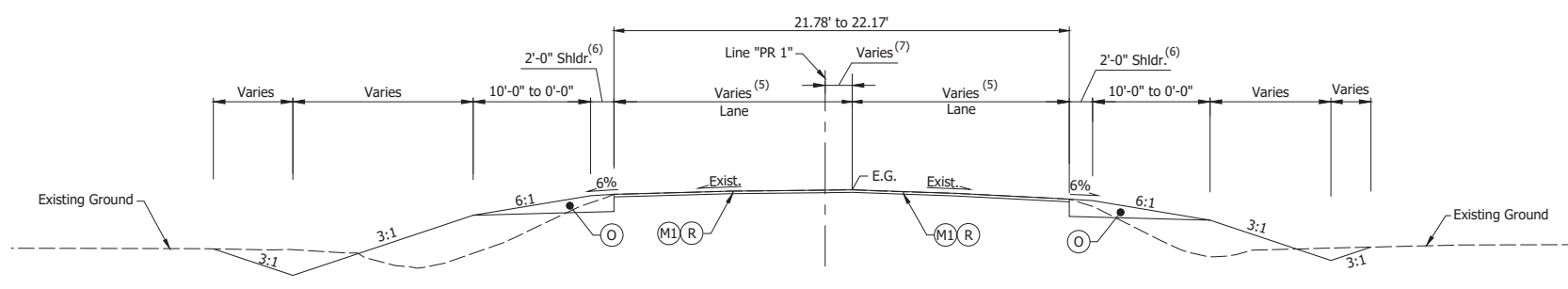

INCIDENTAL TYPICAL SECTION
Sta. 507+74.00 to Sta. 508+34.00

- (5) Match Existing Pavement Width; Varies 10.41 to 11.4'
- (6) Sta. 507+74.00 to Sta. 508+34.00; Trans 2'-0" to 0'-0" Shoulder
- (7) Sta. 507+74 to Sta. 508+34; 0.59' to 1.75'

LEGEND

(R)	165#/SYS QC/QA HMA, 3, 58S, Surface 9.5 mm
(M)	Asphalt Milling, 1.5"
(M1)	Transition Milling
(O)	Variable Depth Compacted Aggregate, No. 53 (10" Max.)
(27)	Mulched Seeding, R
O.F.Z. Obstruction Free Zone Measured from Edge of Travel Lane	

Note:
1) Cross Slope Varies to Match Existing.

RECOMMENDED FOR APPROVAL _____	DESIGN ENGINEER _____ DATE ____/____/____
DESIGNED: SMW	DRAWN: ERO
CHECKED: JAW	CHECKED: SMW

INDIANA DEPARTMENT OF TRANSPORTATION	
TYPICAL CROSS SECTIONS LINE "PR-1"	

HORIZONTAL SCALE 1/4" = 1'	BRIDGE FILE -
VERTICAL SCALE -	DESIGNATION 2001940
SURVEY BOOK	SHEET 5 of 23
CONTRACT B-42732	PROJECT 2001940

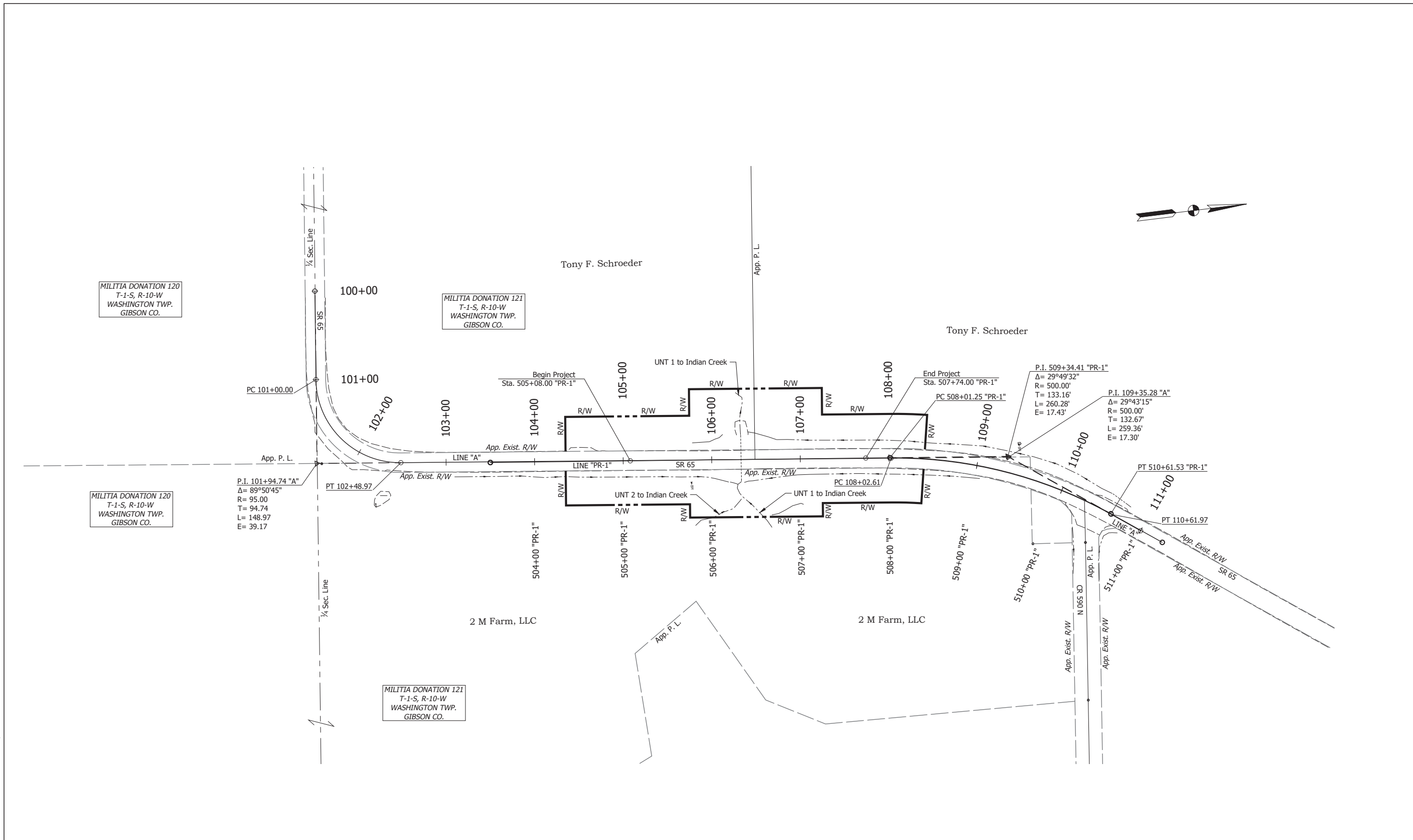

Date: Apr 04, 2024, 11:58am User Name: edison
 File: X:\Production\Files\2021\121-003\1P4-00\10\10\Misc\DWG\Plat No. 1.dwg

Notes:
 1) All Stationing off of Line "A" Unless Otherwise Noted.
 2) All Right-of-Way Described from Line "A".

RECOMMENDED FOR APPROVAL	DESIGN ENGINEER	DATE
DESIGNED: SMW	DRAWN: ERO	
CHECKED: JAW	CHECKED: SMW	

INDIANA DEPARTMENT OF TRANSPORTATION
PLAT NO. 1

HORIZONTAL SCALE	BRIDGE FILE
1"=50'	-
VERTICAL SCALE	DESIGNATION
	2001940
SURVEY BOOK	SHEET
	6 of 23
CONTRACT	PROJECT
B-42732	2001940

Preliminary Design Plans

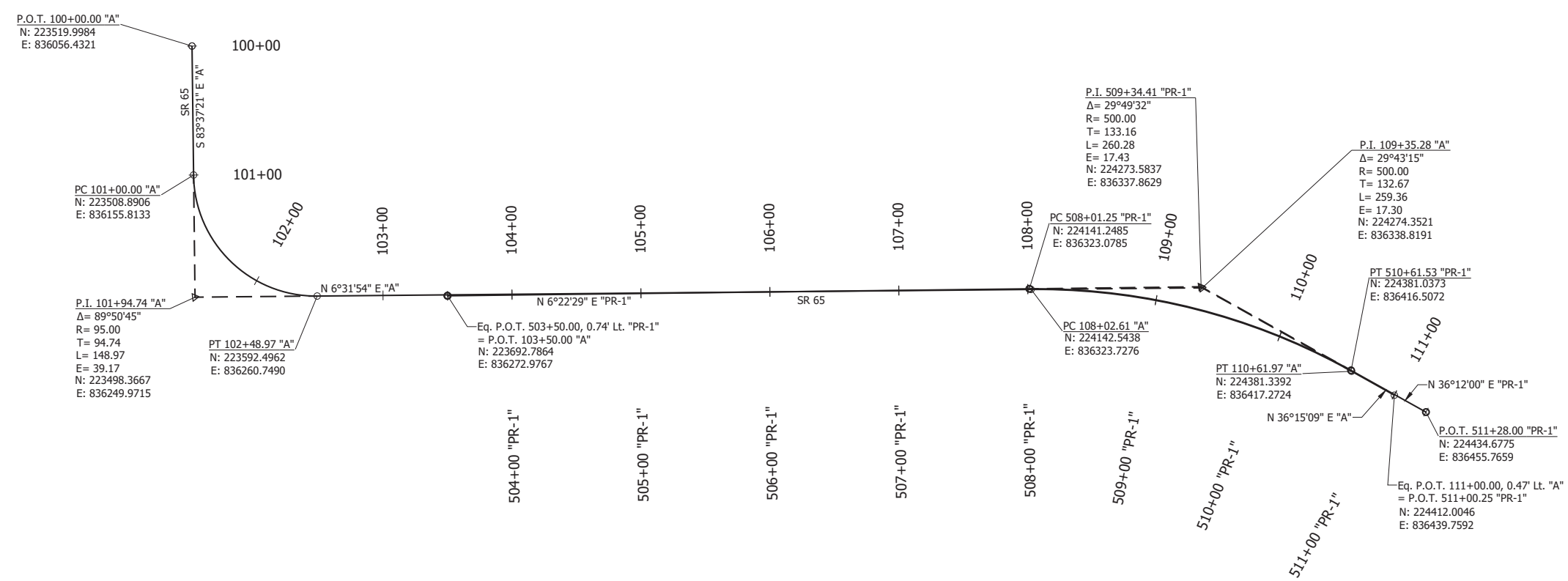

Date: Apr 04, 2024, 11:58am User Name: eobson
 File: X:\Production\files\2021\121-003\194-00\10\10\10\Misc\DWG\Geometric Tie-Up.dwg

RECOMMENDED FOR APPROVAL _____	DESIGN ENGINEER _____	DATE: --/--
DESIGNED: _____ SMW	DRAWN: _____ ERO	
CHECKED: _____ JAW	CHECKED: _____ SMW	

INDIANA
DEPARTMENT OF TRANSPORTATION

GEOMETRIC TIE-UP SHEET

HORIZONTAL SCALE	BRIDGE FILE
1"=50'	-
VERTICAL SCALE	DESIGNATION
	2001940
SURVEY BOOK	SHEET
	7 of 23
CONTRACT	PROJECT
B-42732	2001940

Preliminary Design Plans

BENCHMARKS

BM #1 ELEV. 452.12
 N 223915.5 E 836323.3
 MAG NAIL IN EAST SIDE OF TEL. POLE #LIP-10-01, UP 12"
 STA. 105+77.0, 25.4' RT. LINE A

BM #2 ELEV. 455.53
 N 224287.8 E 836325.8
 MAG NAIL IN EAST SIDE OF POWER POLE #17-2A-9, UP 12"
 STA. 109+39.5, 34.4' LT. LINE A

COORDINATE LISTING: PROPERTY AND DONATION CORNER EVIDENCE FOUND

PT.#	NORTHING	EASTING	DESCRIPTION
6400	224300.443	836898.133	FND. HENNESSEY REBAR/CAP 1" BG
6401	223674.630	834652.022	FND. 5/8" REBAR NO CAP 4" BG
6402	223582.966	835493.060	FND. RR SPIKE 8" DEEP
6403	222124.394	835324.179	FND. SUCKER ROD FLUSH
6404	222046.531	836082.816	FND. 3" IRON PIPE WITH FLAGGING FLUSH
6405	224329.842	836622.323	FND. HENNESSEY REBAR/CAP 2" BG
6406	224348.541	836445.222	FND. 1" O.D. I.PIPE 15" BG
6407	224289.548	836439.351	FND. 1" O.D. I.PIPE LEANING EAST 3" BG
6408	223503.738	836250.921	FND. 1" O.D. I.PIPE LEANING WESTERLY 4" BG
6409	223381.266	836894.315	FND. 5/8" REBAR NO CAP BENT NORTHERLY 4" BG
6410	223548.203	836912.671	FND. 5/8" REBAR NO CAP 1" BG

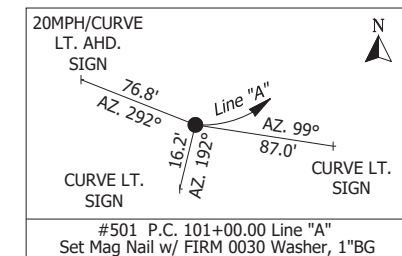
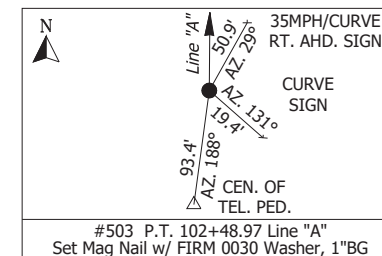
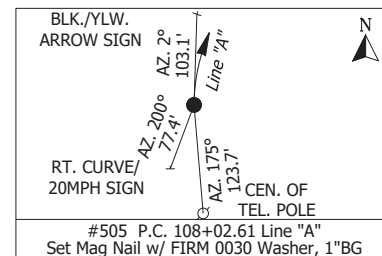
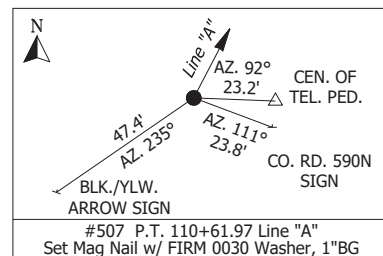

Date: Apr 04, 2024, 11:58am User Name: eobson
 File: X:\Production\Misc\2021\121-0031\140-00\140D\Misc\DWG\Geometric\Tie-Up.dwg

RECOMMENDED FOR APPROVAL _____	DESIGN ENGINEER _____	DATE: --/--
DESIGNED: _____ SMW	DRAWN: _____ ERO	
CHECKED: _____ JAW	CHECKED: _____ SMW	

INDIANA
 DEPARTMENT OF TRANSPORTATION

BENCHMARK & REFERENCE BOXES

HORIZONTAL SCALE	BRIDGE FILE
No Scale	-
VERTICAL SCALE	DESIGNATION
	2001940
SURVEY BOOK	SHEET
	8 of 23
CONTRACT	PROJECT
B-42732	2001940

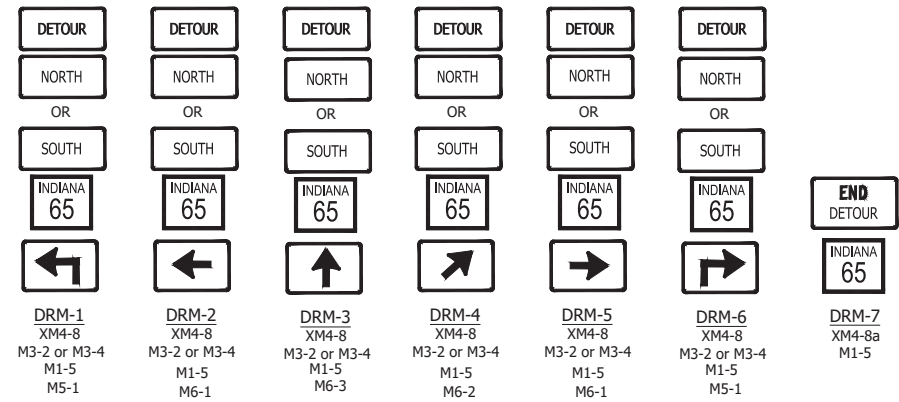
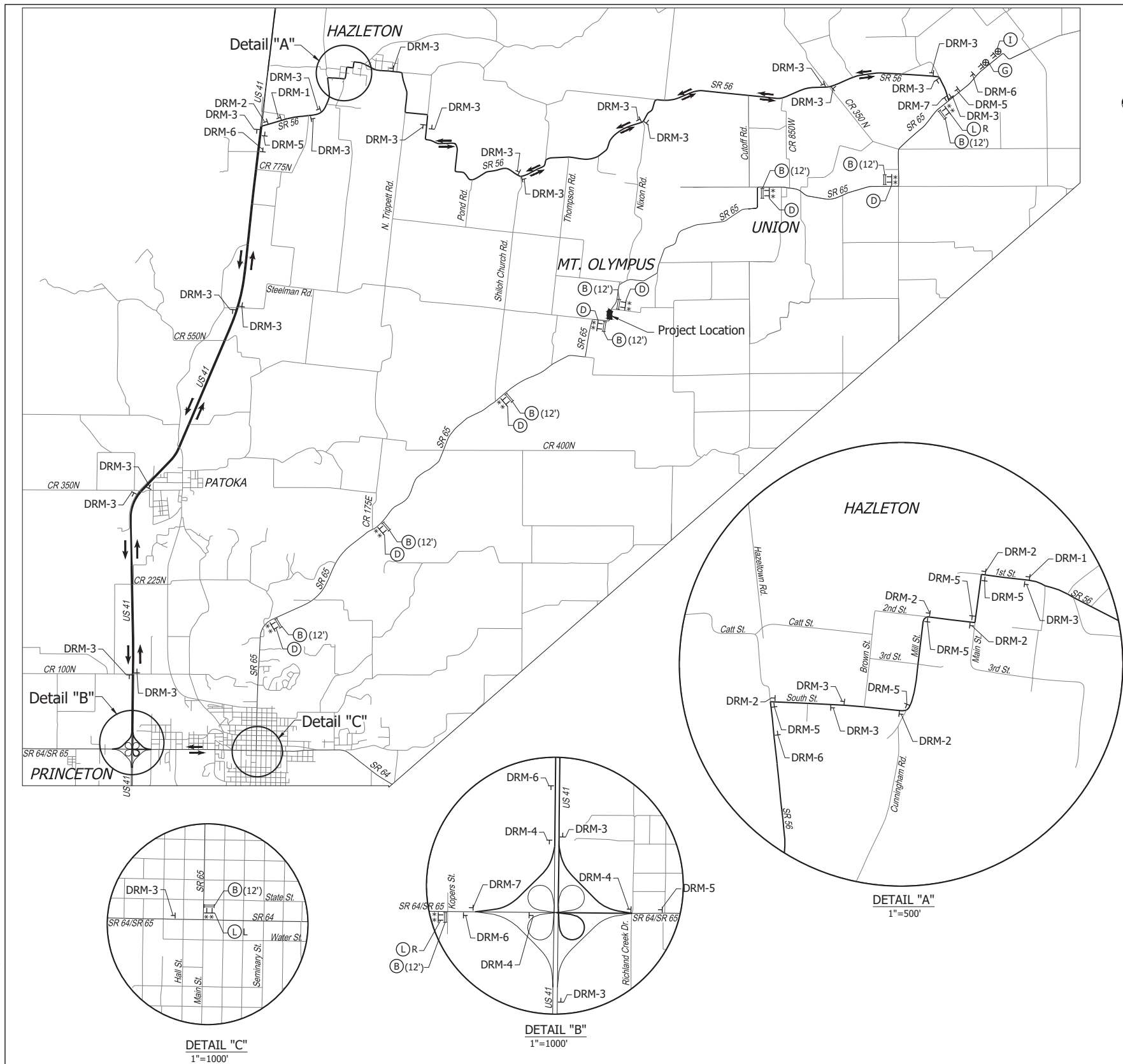

MAINTENANCE OF TRAFFIC QUANTITIES

	Construction Sign, A	Road Closure Sign Assembly	Barricade, III-B	Detour Route Marker Assembly
	Each	Each	LFT	Each
DETOUR	12	12	168	53
TOTAL	12	12	168	53

- Legend**
- (B) Std. Barricade, Type III-B (Feet Req'd.)
 - (C) Construction Sign A, XG20-3 (Road Closed 500 Feet.)
 - (D) Road Closure Sign Assembly; R11-3 (Road Closed xx Miles Ahead)
 - (F) Construction Sign A, XG20-2 (End Construction)
 - (G) Construction Sign A, XW20-2 (Detour Ahead)
 - (H) Road Closure Sign Assembly; R11-2 (Road Closed)
 - (I) Construction Sign A, XG20-3 (Road Closed Ahead)
 - (J) Construction Sign A, XG20-3 (Road Closed 1000 Feet)
 - (K) Construction Sign, A, XW2-6-A (Worksite Penalty)
 - (L) Road Closure Sign Assembly; R11-3 (Road Closed X.X Miles Ahead) w/ M4-10 (L or R) (Detour Arrow)
 - T Detour Route Marker
 - TT Construction Sign
 - ⊗ Construction Warning Light, A
 - ** Construction Warning Light, B
 - ▬ Std. Barricade
 - Work Area
 - Detour Route

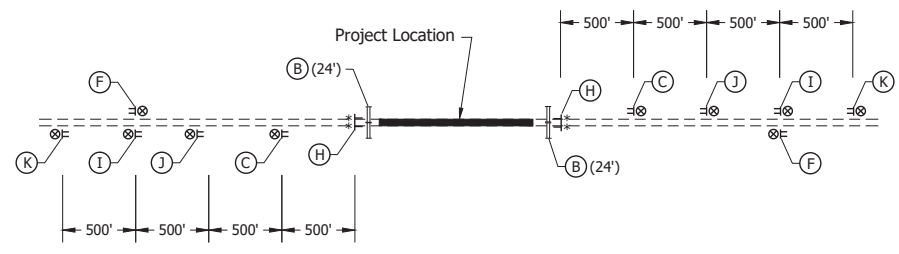

CLOSURE DETAIL
Not To Scale

- Notes:**
- Project Area Along S.R. 65 Shall Be Closed To Thru Traffic. Detour Northbound Thru Traffic North on U.S. 41, & East on S.R. 56 to S.R. 65. Detour Southbound Thru Traffic West on S.R. 56 & South on U.S. 41.
 - Detour Shall Remain In Place Throughout Construction.
 - Contractor Shall Maintain Temporary Access To All Properties During Construction.
 - Signs Shown are Approximate Locations. Actual Locations Should be Determined in the Field by the Project Engineer. 100' Minimum Spacing for Signage.

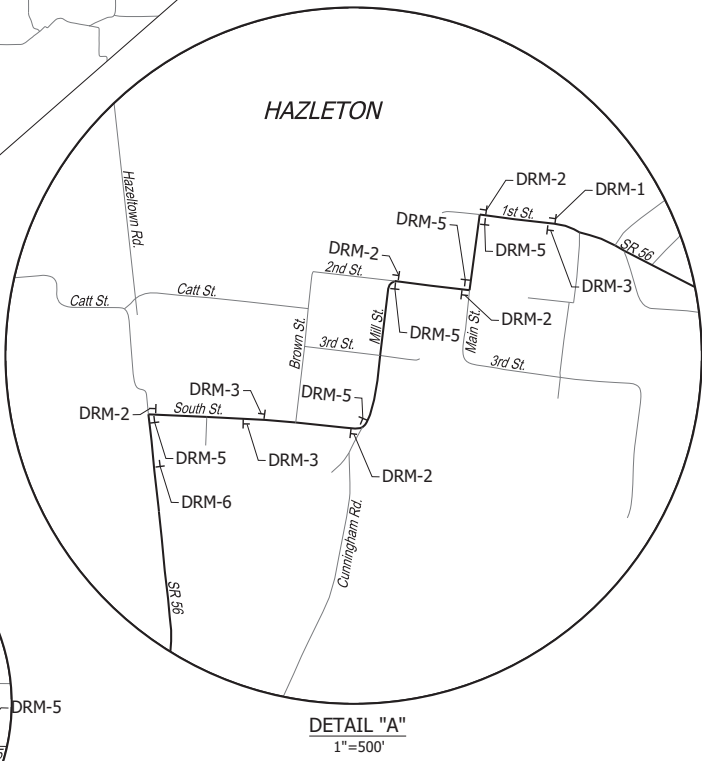
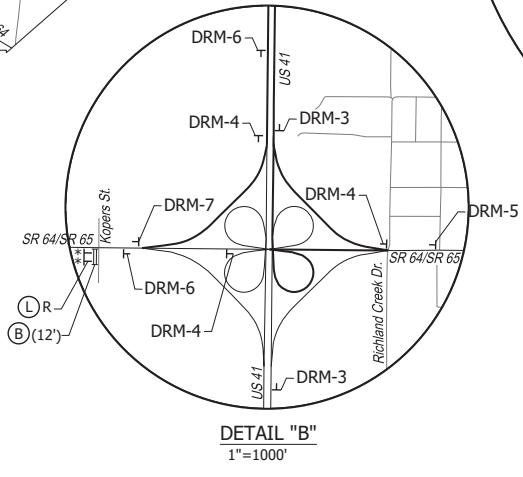
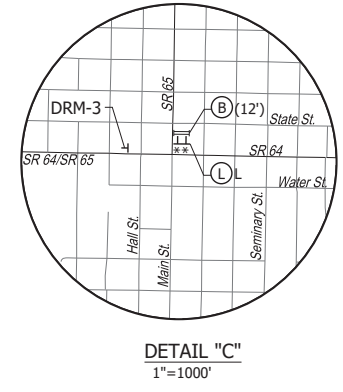

Date: Apr 04, 2024, 11:59am User Name: eobson
File: X:\Production\files\2024\1121\194-003\194-003\CD\194071\194071.dwg

RECOMMENDED FOR APPROVAL	DESIGN ENGINEER	DATE
DESIGNED: SMW	DRAWN: ERO	
CHECKED: JAW	CHECKED: SMW	

INDIANA
DEPARTMENT OF TRANSPORTATION

**MAINTENANCE OF TRAFFIC
DETOUR ROUTE**

HORIZONTAL SCALE	BRIDGE FILE
1"=4000'	-
VERTICAL SCALE	DESIGNATION
-	2001940
SURVEY BOOK	SHEETS
	9 of 23
CONTRACT	PROJECT
B-42732	2001940

Preliminary Design Plans

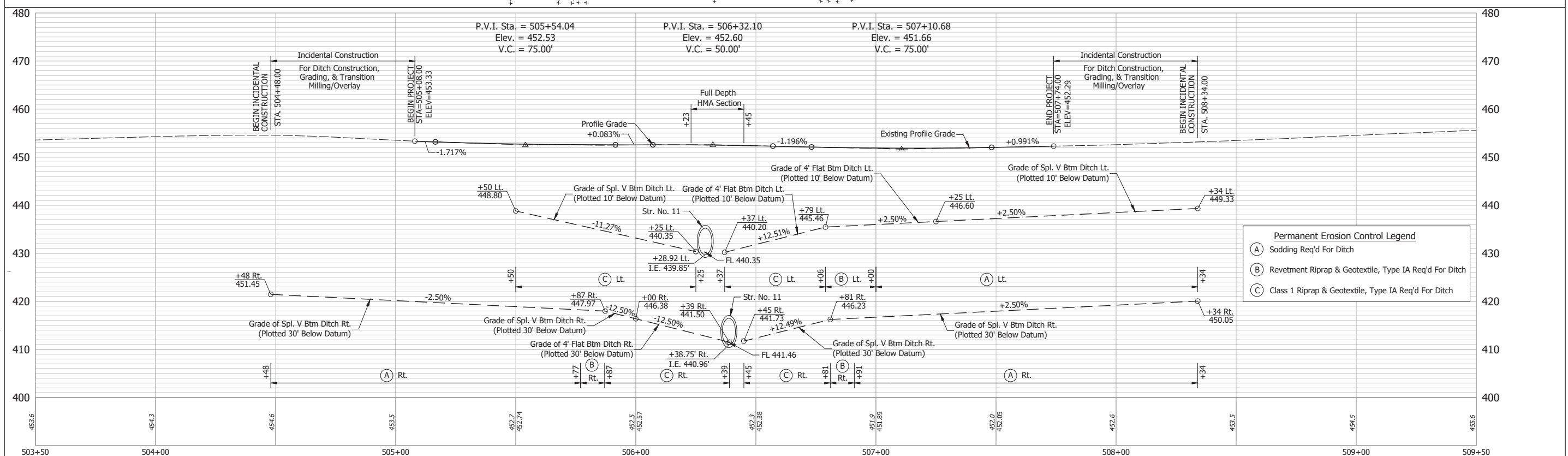
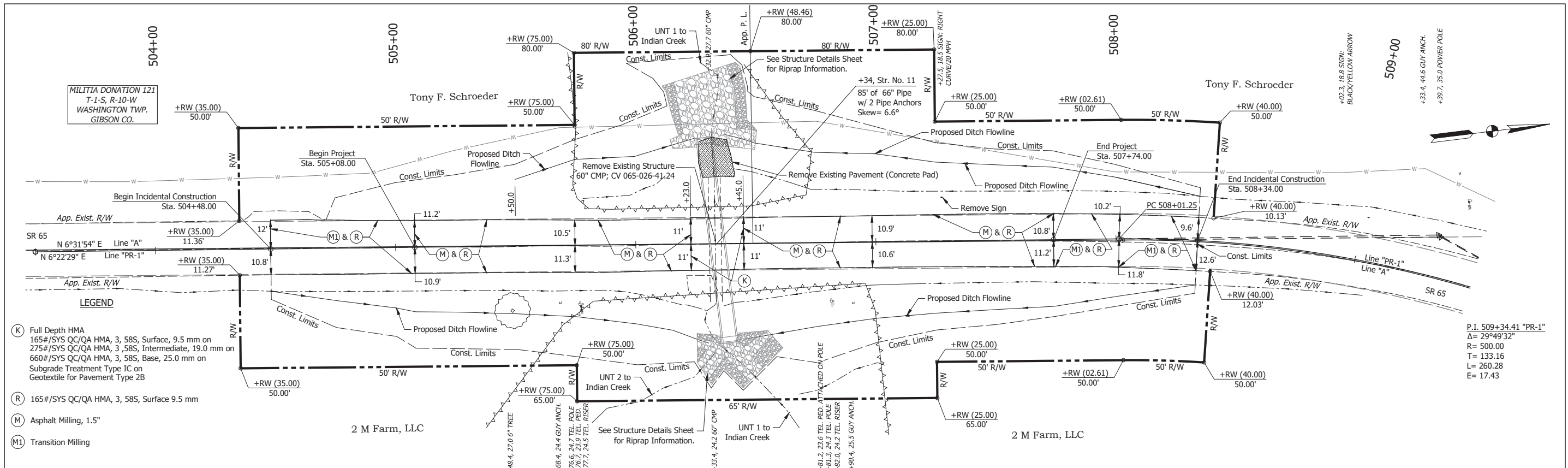

Notes: 1) Station/Offset Topnotes, Benchmarks, & Right-of-Way Described from Line "A". 2) See Geometric Tie-Up Sheet for Alignment Line "A" Information. 3) All Stationing off Line "PR-1" Unless Otherwise Noted. 4) Construction based off Line "PR-1"	RECOMMENDED FOR APPROVAL _____ DESIGN ENGINEER _____ DATE _____	INDIANA DEPARTMENT OF TRANSPORTATION PLAN AND PROFILE LINE "PR-1" STA. 503+50 TO STA. 509+50	HORIZONTAL SCALE 1"=20' VERTICAL SCALE 1"=10'	BRIDGE FILE - DESIGNATION 2001940
	DESIGNED: _____ SMW DRAWN: _____ ERO		SURVEY BOOK _____	SHEET 10 of 23
	CHECKED: _____ JAW CHECKED: _____ SMW		CONTRACT B-42732	PROJECT 2001940

Preliminary Design Plans

Date: Apr 04, 2024, 11:59am User Name: eobson
 File: X:\Production\Files\2021\121-003\194-00\194-00\194-00\Plan and Profile.dwg

Construction Plan - General Plan Components (Section A)

- A-1** Index showing locations of required Plan Elements.
This Sheet
- A-2** Vicinity map depicting site location in relationship to local landmarks, towns, and major roads
Drawings cover page show location/vicinity map.
- A-3** Narrative describing the nature and purpose of the project.
The purpose of this project is replace the existing corrugated metal pipe (CMP) with a new 85 ft L 5.5 ft Dia pipe. Riprap scour protection shall be placed at the new structure inlet and outlet.
- A-4** Project location latitude and longitude.
Latitude: 38.4405357/Longitude: -87.4792717
- A-5** Legal Description of the Project Site
Specifically, the project site is located in:
- Indiana, Gibson County, Union USGS Quadrangle
- Militia Donation 121: T1S, R10W
- A-6** 11 X 17-inch plat showing building lot numbers/boundaries and road layout/names.
See Plat No. 1, Sheet 6
- A-7** 100 year floodplains, floodways, and floodway fringes.
According to the enclosed FEMA FIRM map, no area of the project is located within a mapped floodplain or floodway.
- A-8** Adjacent landuse
Adjacent land is dominated by agricultural areas.
- A-9** Identification of any US EPA approved or established TMDL.
No named or identified TMDLs are located within the project watershed.
- A-10** Identification of all receiving waters.
UNT 1 and 2 to Indian Creek, Indian Creek, Goose Creek, Patoka River
- A-11** Identification of discharges to a water on the current 303(d) list.
Patoka River is on the 303 (d) list for E. Coli., PCBS in fish tissue, and Biological Integrity
- A-12** Soils map including soil descriptions and limitations.
Soil Map was derived from the USDA Soil Survey of Gibson County, IN. See enclosed soils map and report.
- A-13** Location and name of all wetlands, lakes and water courses on and adjacent to the site.
UNT 1 and 2 to Indian Creek
- A-14** Notation of any State or Federal water quality permits.
IDEM 401 WQC: Applied for concurrently
- A-15** Identification of existing vegetative cover, including natural buffers.
Agricultural fields, scrub-shrub along channel, maintained right-of-way grasses.
- A-16** Existing site topography.
See Plan and Profile Sheets
See Cross-section Sheets
- A-17** Locations where run-off enters the project site.
Runoff will enter the site from adjacent agricultural fields.
- A-18** Locations where run-off discharges from the project site.
Stormwater runoff will be exit the site via roadside ditches into UNT 1 to Indian Creek.
See Plan and Profile Sheets for locations.
- A-19** Location of existing stormwater systems/structures.
See Plan and Profile Sheets
- A-20** Existing permanent retention or detention facilities.
No retention or detention facilities are available.
- A-21** Identification of potential discharges to ground water.
There are no known areas within the project site where stormwater will be discharged to groundwater.
- A-22** Project Area
Total Acreage: 1.08 ac
- A-23** Proposed Land Disturbance
Total Acreage: 0.7 ac
- A-24** Proposed final topography.
See Plan and Profile Sheets
See Cross-section Sheets
- A-25** Locations and approximate boundaries of all disturbed areas.
Plan and Profile Sheets show the anticipated work areas.
Disturbance is anticipated to remain within the designated work areas.
- A-26** Locations, size, and dimensions of all stormwater drainage systems.
Plan and Profile Sheets show locations of the proposed stormwater system (roadside ditches, culvert replacement).
- A-27** Specific points where stormwater discharge will leave the site.
The project drains into UNT 1 to Indian Creek via roadside ditches.
See See Plan and Profile Sheets these locations.
- A-28** Locations of all proposed site improvements.
Plan and Profile Sheets show locations of the proposed improvements.
- A-29** Locations of proposed soil stockpiles and/or borrow/disposal areas.
Offsite disposal of demolition debris is anticipated for this project. Waste sites shall be accepted by the Engineer prior to the start of any disposal operations. For each proposed disposal site, an IC-203 Request for Acceptance of Borrow or Disposal Site form shall be submitted to the Engineer a minimum of 14 days prior to the Contractor's planned start of disposal operations. All requests for acceptance of disposal sites shall be in accordance with INDOT Standard Specification 203.08(a). During development of the SWQCP the Contractor shall identify any on-site stockpiles add them to the SWPPP drawings. All on-site stockpiles shall be protected with proper E&S BMPs (i.e. surround with filter sock) to prevent sediment discharges into adjacent properties, water resources and stormwater systems.
- A-30** Location of any construction support activities (i.e. laydown yard, concrete batch plant, staging areas, etc.).
Proposed laydown and material storage areas shall be identified by the Contractor, accepted by the Engineer, and identified on the SWPPP prior to Contractor mobilization. When siting laydown and material storage areas, the Contractor shall avoid sensitive areas such as proximity to water resources (wetlands, streams, stormwater inlets, etc.) or other environmentally sensitive resources (i.e. karst). Support activities shall be directly related to the construction site and not a commercial/industrial operation or serve multiple unrelated construction projects. Support activities must not continue to operate beyond the completion of the construction activity for the project it supports. Contractor shall be responsible for ensuring proper E&S BMPs are installed around these areas to prevent sediment and chemical discharges into adjacent properties, water resources or stormwater systems.

Construction Plan - General Plan Components (Section A - Cont'd)

- A-31** Location of any in-stream activities.
Culvert replacement will require work within UNT 1 to Indian Creek.

Stormwater Pollution Prevention - Construction Component (Section B)

- B-1** Description of potential pollutant sources associated with the construction activities:
Potential pollutant sources associated with this construction activity include those normally associated with construction equipment and construction activities such as: concrete wash-out water, soil sediment, oils, fuels, hydraulic fluids, transmission fluids, brake fluid, antifreeze, greases, brake dust, etc. All heavy equipment shall be parked on site at a location, when not in use; leakage from the equipment will be captured by the surrounding terrain, and not be provided a direct path to the surrounding stormwater system. Sediment discharge will be controlled by proper work sequencing and proper installation of E&S BMPs. Concrete wash-out water shall be controlled through proper construction of concrete wash-out containments.
- B-2** Construction Entrance:
The Contractor shall install stable entrances/exits at any location where the contractor plans to enter and exit the site to reduce the amount of mud and sediment tracked onto public roads. Recommended locations for these entrances are shown in the SWPPP but may need to be relocated to support contractor's sequence of work. Any mud, soil, rock, etc. tracked onto open public roads shall be immediately removed. CEs shall be installed in accordance with INDOT standard drawing E-205-TECD-12.
- B-3** Specifications for temporary and permanent stabilization:
Temporary surface stabilization shall be accomplished by the use of a temporary seed mixture along with temporary mulching. The temporary seed mixture shall be used to establish a temporary cover for disturbed soils during the construction operations. Temporary seeding (INDOT Seed Mix T) shall be placed on disturbed areas that are expected to be idle for 7 days or greater, or as directed by the Engineer. Placement of temporary surface stabilization shall be completed per INDOT Standard Specification 205.04.

Permanent surface stabilization shall be achieved by the use of pavement, sod and a permanent seed mixture (INDOT Seed Mixture R), along with mulching material and fertilizer. Placement of the permanent surface stabilization shall immediately follow final grading of an area and shall be completed per INDOT Standard Specification 621 unless otherwise specified.
- B-4** Sediment control measures for concentrated flow areas:
Modified Check Dam (MCD): MCDs are erosion control features installed toe-to-crest in concentrated flow areas to slow runoff and reduce erosion. Proposed locations for these measures are shown on the plans, but may need to be modified and/or replaced based on the phasing and locations of active construction. MCDs shall be installed in accordance with INDOT Standard Dwg. E-205-TECD-06.
- B-5** Sediment control measures for sheet flow areas:
Filter Socks (FS): A temporary barrier consisting of permeable material (compost or mulch) contained in a permeable geotextile fabric or non-biodegradable net matrix installed to intercept and treat sediment-laden runoff from small unvegetated, or disturbed drainage areas. They will trap sediment by intercepting runoff and reducing the velocity of the runoff into stabilized areas. They shall be installed in accordance with INDOT Standard Drawing E 205-TECD-10 and manufacturer recommendations.
Vegetative Filter Strip (VFS): A vegetative filter strip is an area where the ground cover is to be left undisturbed to help filter runoff from disturbed drainage areas. Contractor shall not disturb any vegetation located outside of the construction limits. During construction, this vegetation shall work in conjunction with perimeter protection to filter runoff before it leaves the site. After construction is complete all disturbed areas shall be permanently stabilized in accordance with B-3 to establish permanent vegetation.
- B-6** Runoff control measures:
Concrete Washout (CW): Concrete washout areas shall be installed and utilized as containment for washing equipment of uncured concrete and associated liquids. They shall be constructed in accordance with INDOT Standard Specification 205.03 and the Erosion Control Detail Sheet. Straw bales shall not be used in the construction of concrete washout areas. All concrete washout water shall be discharged to a concrete washout area. CW's will be placed a minimum of 50 feet from any body of water and located away from inlets and stormwater conveyances. They shall be placed on stable material and in such a manner that all washout water is captured and contained in the CW.
Filter Sock (FS): See B-4 for details.
Vegetative Filter Strip (VFS): See B-5 for details.
- B-7** Stormwater outlet protection specifications:
No outlet protection is anticipated for this project.
- B-8** Grade stabilization structure locations and specifications:
Disturbed grades shall be stabilized in accordance with B-12 and as shown in the drawings.
- B-9** Dewatering application and management methods:
Dewatering: While dewatering is not specified in the SWPPP design it may be required to remove water collected in excavations or other low areas. Proper outflow of the dewatering activity should be reviewed and planned for to prevent discharge of sediment laden runoff into adjacent storm sewer inlets. Dewatering components include pump, water filtering device (sediment bag), stabilized outlet, and secondary containment (check dam, silt fence, filter sock, etc.).
- B-10** Measures utilized for work within waterbodies:
Pump-Around: Prior to any work within UNT 1 to Indian Creek, a properly sized an configured pump-around shall be installed. Dewatering pump shall discharge into a properly sized sediment bag placed on a level & stable non-erodible surface protected by secondary containment. Secondary containment shall consist of a filter sock, MCD, or other sediment control method approved by the Engineer.
- B-11** Monitoring and maintenance guidelines for each proposed pollution prevention measure:
In accordance with INDOT Specification 205, the contractor shall develop a Storm Water Quality Control Plan (SWQCP). The SWQCP shall include the processes and procedures of how the Contractor intends to meet the requirements as outlined in INDOT Standard Specification 205 and the approved SWPPP. Any individual phase of the SWQCP shall be submitted to the Engineer for review a minimum of 14 calendar days prior to commencing earth disturbing activities for that phase. Temporary erosion and sediment control measures shall be self-inspected by the Contractor's SWQM, once every seven days and within 24 hours of a 1/2 inch measurable storm event. Inspections shall be documented and records shall be maintained by the Contractor's SWQM and be made available for review upon request. Records shall include, at a minimum: date, inspector's name, maintenance and corrections needed based on the inspection, and status of previously identified deficiencies. INDOT Form 108-c-192d: Storm Water, Erosion, and Sediment Control Inspection Report may be utilized and is available on INDOT's website for use. The temporary protection measures shall be returned to good working condition within 48 hours after inspection or as directed. Inspections shall continue until the entire contract is complete and has been permanently stabilized and the Notice of Termination has been filed with the reviewing authority.

Stormwater Pollution Prevention - Construction Component (Section B - Cont'd)

- B-11** Monitoring and maintenance guidelines for each proposed pollution prevention measure (Cont'd):

The following shall apply to maintaining the specific erosion and sediment control facilities:

- **Construction Entrances:**
 - **Inspection**
 - Verify entrances are where they are most effective.
 - Ensure entrances do not interfere with existing drainage patterns.
 - Inspect entrances each day they are being used.
 - Monitor tracking onto public roads and observe sediment being collected in the stone.
 - **Maintenance**
 - Redress #2 stone as necessary to provide clean stone with voids capable of trapping additional sediment.
 - Remove and replace #2 stone on construction entrances near sensitive areas or where redressing could cause a safety or drainage problems.
 - Sweep or otherwise remove sediment from public roads at the end of each day and throughout the day as necessary.
 - Reshape, resize or relocate ineffective construction entrances.
- **Modified Check Dam**
 - **Inspection**
 - Ensure center of dam is lower than the sides and that the sides tie into the slope so water flows across center of dam.
 - Check for #5 or #8 filter stone on front face of dam.
 - Geotextile under dam should extend 3 feet down slope.
 - Inspect for channel erosion. If channel erosion is found, space check dams closer so that the bottom of the upstream dam is aligned with the weir of the downstream dam.
 - **Maintenance**
 - Remove sediment once it reaches one-half the height of the check dam.
 - Repair or replace if damaged or ineffective.
- **Filter Sock:**
 - **Inspection**
 - Monitor sediment accumulation and remove one it reaches one-quarter of the height of the filter berm/sock.
 - Look for areas that been damaged by storm water or equipment.
 - **Maintenance**
 - Replace or resecure damaged filter socks.
 - Replace with rock or stronger measure if damage is sever or reoccurring.
 - Remove accumulated sediment once it reaches one-quarter of the height of the filter berm.
- **Vegetative Buffers**
 - **Inspection**
 - Inspect for the beginning of erosion rills or channel erosion.
 - Inspect for sediment accumulation.
 - **Maintenance**
 - Promptly repair any small rills that form.
 - Add fertilizer and soil amendments as needed to maintain healthy vegetation.
 - Mow as needed but not shorter than four inches.
 - Where the filter strip has actively trapped sediment during construction, remove the accumulated sediment, regrade the area and reseed it when conditions are favorable for vegetative establishment.
- **Concrete Washout**
 - **Inspection**
 - Make sure all concrete slurry can be contained within the washout provided. Construct additional washouts as needed.
 - Inspect daily during concrete placement operations.
 - Ensure washout is completely contained with one sheet of plastic free of tears.
 - Dispose of cured concrete per specifications.
 - **Maintenance**
 - Repair or replace if leaks, spills or tears are found.
 - Provide additional concrete washout as needed to ensure adequate capacity.

The SWQM, shall routinely inspect the overall performance of erosion and sediment control facilities and areas downstream of the project site. If eroded material/silt is apparent downstream from the facilities, some failure has occurred, and the inspector shall notify the Contractor and Engineer. The Contractor shall remove the accumulated sediment downstream and add additional erosion and sediment control measures to address the issues as necessary. The contractor shall implement all recommended solutions to the problem areas as recommended by the SWQM, Engineer, IDEM, or local inspector within 48-hours.

Following completion of construction and final stabilization of all disturbed areas, the Contractor shall dismantle the remaining temporary erosion and sediment control elements. The contractor shall remove any unsuitable material from the site left from the erosion and sediment control measures. The disturbed areas, following removal of the temporary measures, shall be stabilized with permanent vegetation. When all construction is complete, temporary measures have been removed, and vegetation is established, the SWQM and Engineer shall complete a final release inspection.

Date: Apr 04, 2024, 11:59am User Name: nobson
File: X:\Production\Files\2021\121-003\194-00\CD\Revision\EC_Details.dwg

RECOMMENDED FOR APPROVAL _____		DESIGN ENGINEER _____ DATE --/--/--		INDIANA DEPARTMENT OF TRANSPORTATION		HORIZONTAL SCALE		BRIDGE FILE	
DESIGNED: _____ SMW		DRAWN: _____ ERO				No Scale		-	
CHECKED: _____ JAW		CHECKED: _____ SMW		EROSION/SEDIMENT CONTROL DETAILS		VERTICAL SCALE		DESIGNATION	
						-		2001940	
						SURVEY BOOK		SHEETS	
						11 of 23			
				CONTRACT		PROJECT			
				B-42732		2001940			

Preliminary Design Plans

Assessment of Stormwater Pollution Prevention Plan (Cont'd)
Construction Component (Section B)

B-12 Planned construction sequencing:

Upon completion of the initial site inspection, and before any vegetation is removed from the site, this erosion and sediment control plan shall be implemented. The plan must be dynamic and ever changing as the project develops. Proper sequencing of work may reduce the amount of bare soil and therefore reduce the need for extensive erosion and sediment control measures. Every detail of stormwater and erosion protection cannot be planned in advance. The measures shown within these drawings are considered to be the minimum protection required. The contractor must be prepared to implement additional measures as needed to prevent sediment loss when weather or work activities dictate. Continual maintenance and updating of the plan by the construction contractor is of utmost importance. Below is a general sequencing of events for this erosion and sediment control plan. While the contractor shall dictate the actual sequencing of construction, erosion and sediment control measures shall be implemented as described below during each phase of construction.

- Flag or denote all construction limits.
- Contractor shall develop a Storm Water Quality Control Plan (SWQCP) that shall include a Concrete Waste Water Plan and establish areas for storage of potential pollutants (e.g. concrete washout, fuel storage, hydraulic fluids, etc.). SWQCP shall be provided to the Engineer a minimum of 14 days prior to commencement of earth moving activities.
- A pre-construction meeting with the owner, contractor, and contractor's Storm Water Quality Manager (SWQM) shall be held.
- Identify and protect all existing vegetation designated to be undisturbed.
- Prior to removal of existing vegetation or pavement:
 - Install rock filter berms prior to slope grading.
 - Install MCDs immediately following ditch grading/shaping.
 - MCDs shall remain in place until ditch line is properly stabilized.
 - Install construction entrances as needed to prevent sediment from being carried onto public roads.
 - Immediately remove any sediment, mud, debris, etc. carried onto open public roads.
 - Install filter sock perimeter protection.
 - Identify and protect all vegetation to remain undisturbed to act as vegetative buffer.
 - Proposed locations for these measures are shown on the plans, but may need to be modified and/or replaced based on the contractor's approved SWQCP.
- Prior to placement of any concrete, install concrete washouts where needed and in accordance with approved Concrete Waste Water Plan to ensure that no concrete washout water enters road side ditches, comes in contact with the ground, or leaves the project limits.
 - Concrete washouts shall be located no closer than 50 feet from any jurisdictional waterway, body of water, wetland or stormwater inlet.

B-13 Erosion and sediment control specifications for individual building lots:

Not applicable.

B-14 Material handling and spill prevention plan:

Contractor's SWQM will develop a Concrete Waste Water Plan that will be provided to the Engineer a minimum of 14 days prior to any concrete placement. Any onsite storage of hazardous materials/potential pollutants, such as diesel fuel, shall be stored onsite surrounded by an earthen dike or other secondary containment system having a storage volume equal to 150% of tank capacity, to contain potential pollutants. Any additional means of containing releases should be accessible to a petroleum storage area; this would include various absorbent materials. Furthermore, all equipment, when not in use, shall be parked onsite in an area that, should potential pollutants leak, will be contained within the immediate area and will not be inadvertently conveyed to drainage swales and away from the project. Any leakage of pollutants from storage vessels or equipment shall be cleaned up and disposed of offsite in a legal manner. In the event of a release, a licensed environmental consulting company shall be contacted for spill cleanup assistance. The spill shall be reported to both IDEM's 24-hour emergency response line at (888) 233-7745 and Gibson County dispatch at (812) 385-3496 or 911 for local emergency response.

B-15 Material handling and storage procedures associated with construction activities:

Proposed waste storage areas shall be identified by the Contractor and accepted by the Engineer prior to Contractor mobilization. Garbage and construction debris shall be gathered and stored in a properly sized roll off container. Tarps or other forms of cover may be required to keep debris in dumpster during high winds. Concrete wash-out water shall be directed into leak-proof containers or leak-proof containment areas which are located and designed to divert stormwater run-off away from the measure. Size concrete washouts to prevent the discharge and/or overflow of wash water. Waste sites shall be accepted by the Engineer prior to the start of any disposal operations. For each proposed disposal site, an IC-203 Request for Acceptance of Borrow or Disposal Site form shall be submitted to the Engineer a minimum of 14 days prior to the Contractor's planned start of disposal operations. All requests for acceptance of disposal sites shall be in accordance with INDOT Standard Specification 203.08(a).

Stormwater Pollution Prevention Plan - Post Construction Component (Section C)

C-1 Description of pollutants and their sources associated with the proposed land use:

Additional pollutant sources will be from trash (both organic and inorganic), lawn chemicals, grass clippings, grit brought in from the existing surrounding roads from various vehicles (fuel, antifreeze, oil, grease, brake dust, brake fluid, transmission fluid, other hydrocarbons, etc.), pet and other animal waste, etc.

C-2 Description of proposed post construction storm water quality measures:

All disturbed areas within the construction limits not paved shall be graded, seeded, and established as permanent vegetated filter strips and swales in accordance with the INDOT Standard Specification 621 and the SWQCP. Chapter 8 of the Indiana SWQM identifies 81% removal of total suspended solids (TSS) through the use of vegetated swales. Vegetated filter strips are anticipated to remove greater than 81% TSS and will be the primary post construction storm water quality control measure.

C-3 Plan details for each stormwater measure:

See Plan and Profile Sheets for roadside ditch locations.
See Structure Detail Sheets for riprap scour protection details.

C-4 Sequence describing stormwater quality measure implementation:

Upon completion of the intersection improvement, all disturbed soil will be graded to final contours and stabilized in accordance with these drawings and B-3. No additional permanent stormwater quality measures are anticipated for this project. All existing vegetation outside of the project limits will not be disturbed, and this vegetation will continue to filter out pollutants from the stormwater prior to it leaving the site, and entering into the surrounding water sources.

C-5 Description of maintenance guidelines for proposed post-construction water quality measures:

Erosion and sediment control: Repair and revegetate eroded areas in the project site. Remove debris, grit, trash, etc. from stormwater inlets. These measures will be implemented, as needed, based on regular inspections by INDOT and Gibson County highway maintenance personnel.

C-6 Entity responsible for operation and maintenance of post-construction stormwater measures:

Following construction, the area shall be maintained in by INDOT and Gibson County highway maintenance personnel according to their standard operating procedures in regards to inspections, mowing, debris and litter removal, nuisance control, sediment removal, and general right-of-way maintenance.

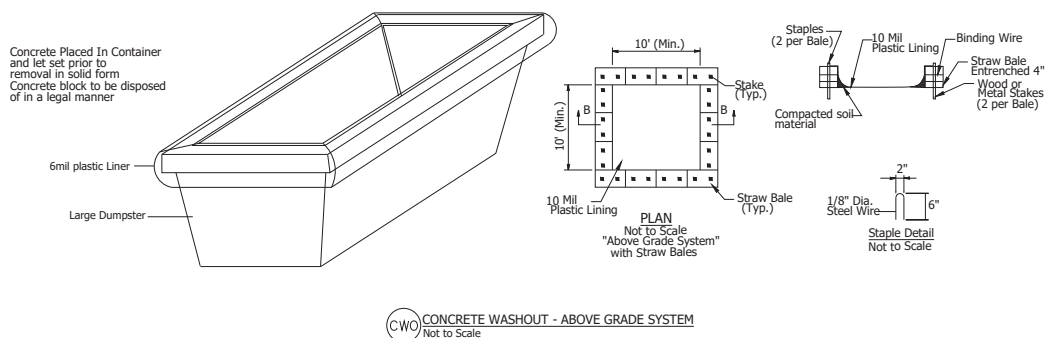
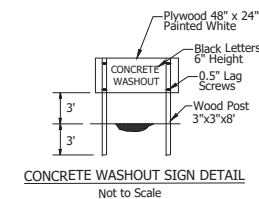

CWO CONCRETE WASHOUT - ABOVE GRADE SYSTEM
Not to Scale

Concrete Washout:
Concrete washout systems can be manufactured systems or systems constructed on site above grade.

Design Considerations:

- * Sizing Considerations:
 - ** Storage volume of the containment structure should correlate to the anticipated amount of plastic cementitious material used for construction.
 - ** Washout sizing must include provisions for mortar operations
 - *** Provide source of clean water for washing tools
 - *** Capture washwater and/or transfer to containment structure
 - ** Estimating washwater volumes for concrete deliveries can be highly variable due to weather, air temperature, product slump, concrete temperature, and number of chutes used:
 - *** One method to estimate washwater volume is to use 20 to 40 gallons per ready mix truckload (20 to 40 gallons x total cubic yards (~8 cubic yards per truckload) = total estimated gallons washwater generated)
 - *** For concrete pump trucks allow for a minimum of 50-gallons of washwater per pump use
 - * When sizing washout, contractor must include an additional 25% freeboard to ensure structure will not overflow.
 - * System shall be designed to eliminate run-off and minimize precipitation from entering the washwater containment system.

Structure Specifications:

- ** Manufactured systems or disposable containments.
- ** Use the required materials or components according to product specifications.
- * Structures built on-site must be watertight.
 - ** Must have strength to resist failure or collapse for duration of the project or use.
 - ** Washout systems should be a minimum of ten feet wide by ten feet long, but sized to contain all liquid and waste that is expected to be generated between scheduled clean-out periods.
 - *** Washout size may be limited by the available size of polyethylene.
 - *** Polyethylene lining shall be a single continuous sheet, sufficient to adequately line the entire containment and have a minimum thickness of 10-millimeter.
 - *** Must be durable, resistant to washwater chemistry, and weathering or deterioration.
 - *** Must be free of defects, holes, rips or tears.
 - *** The bottom of the washout shall level and clean of sticks, stumps, rocks and other debris that may penetrate the liner.
- ** Install signage identifying location of washwater containments/facilities and to discourage disposal of non-washwater materials into washout facilities.
- * Provide maximum fill level indicator to allow sufficient capacity in the containment to avoid overflowing or overflows.
- ** Containments shall not be filled beyond 75% of the containment capacity.

Date: Apr 04, 2024, 11:59am User Name: eobson
File: X:\Production\Files\2021\121-0031\PA-00-00\CD\EROSION/EC_Details.dwg

RECOMMENDED FOR APPROVAL _____	DESIGN ENGINEER _____ DATE _____	INDIANA DEPARTMENT OF TRANSPORTATION	HORIZONTAL SCALE	BRIDGE FILE
			No Scale	-
DESIGNED: _____ SMW	DRAWN: _____ ERO	EROSION/SEDIMENT CONTROL DETAILS	VERTICAL SCALE	DESIGNATION
CHECKED: _____ JAW	CHECKED: _____ SMW		-	2001940
			SURVEY BOOK	SHEETS
			CONTRACT	12 of 23
			B-42732	PROJECT
				2001940

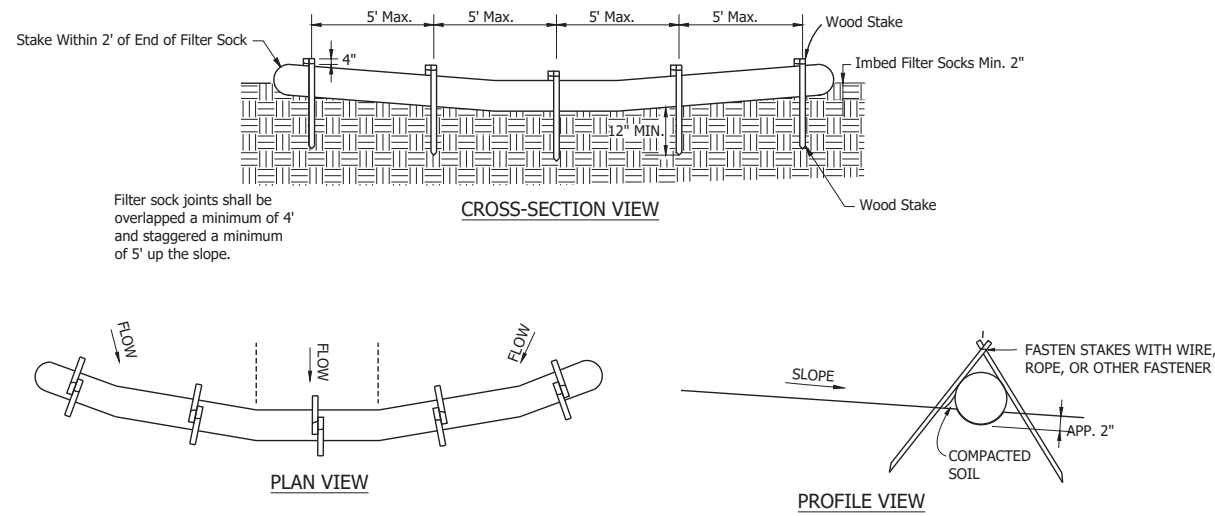

Filter sock joints shall be overlapped a minimum of 4' and staggered a minimum of 5' up the slope.

Filter Sock Size Requirements, Sheet Flow Application

Slope	<50:1	8 inch	12 inch	18 inch	24 inch
0% - 2%	<50:1	125	250	300	350
2% - 10%	50:1 - 10:1	100	125	200	250
10% - 20%	10:1 - 5:1	75	100	150	200
20% - 33%	5:1 - 3:1	25	50	75	100
>33%	>3:1	10	25	50	75

FS FILTER SOCK
Not to Scale

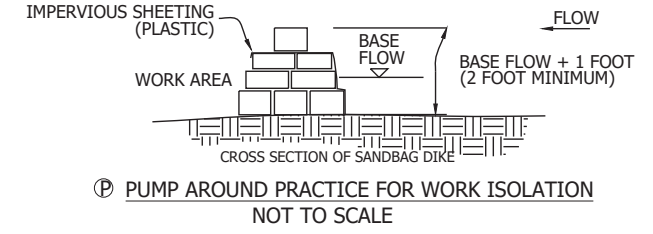
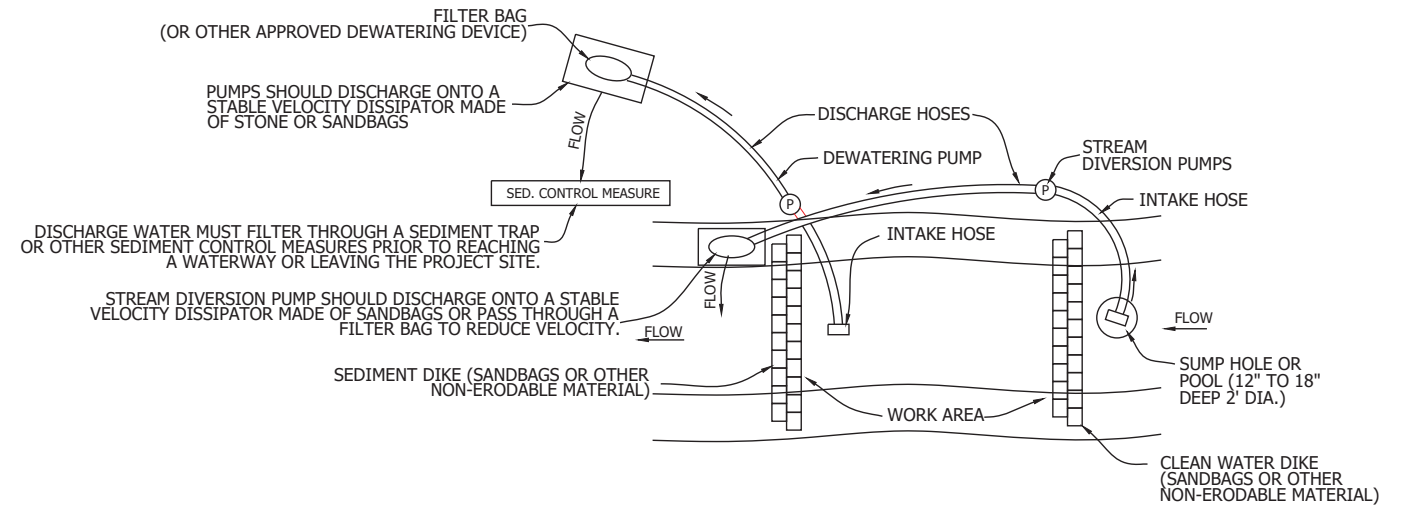

PUMP AROUND PRACTICE FOR WORK ISOLATION
NOT TO SCALE

PUMP AROUND

- Dewatering of the project area shall be performed using a mechanical pump. A dewatering (filter) bag shall be securely connected to the end of the discharge hose. The suction hose shall be floated as long as possible to prevent the pump from pulling sediment from the bottom of the pooled area.
- The dewatering bag may be of the single-use or reusable variety and shall be constructed of non-woven, polypropylene geotextile material. Each type and size of dewatering bag can handle varying rates of flow.
- The bag shall have for following minimum specifications:

Permittivity	Grab Tensile	Weight	Apparent Opening Size
1.4 sec	205 lbs	8 oz/syd	80 US Sieve
- The dewatering bag shall be placed on a flat surface.
 - 4.1. Placing the dewatering bag on top of an aggregate base will help to increase flow through the fabric by providing a larger surface area of discharge.
- Water shall not be pumped from the project area at a rate faster than the manufacturer's maximum recommended flow rate of the dewatering bag.
- Dewatering bags shall be placed in a location in which runoff will pass through additional sediment control measures prior to entering the storm sewer.
- Following completion of dewatering, the sediment accumulated within the dewatering bag shall be removed from the bag and placed in an upland area.

Materials & Specifications:

*INDOT Riprap
*INDOT CA No. 5 aggregate, CA No. 8 is acceptable if No. 5 aggregate is not available. The use of No. 8 stone may result in more frequent overtopping of the structure and will increase the frequency of structure maintenance.

Installation

- Place a ring of riprap to a minimum height of 24" and tie the ends into a level contour with a minimum of 24" water pooling depth of the deepest point. Construct the aggregate donut such that it has a 1:1 or flatter outside slope and a 2:1 or flatter inside slope.
- The Rock Filter Berm shall be a minimum of 20' in length.
- Cover the outside face of the filter berm with at least a 12 inch thick layer of INDOT CA No. 5 aggregate (for filtration). Maintain a 2:1 or flatter slope.

Maintenance

- * Inspect the structure after each storm event, and repair any damage immediately.
- * Remove sediment from the pool area to ensure adequate runoff storage for the next rain.
- * When the contributing drainage area has been stabilized, remove all construction materials and sediment and dispose of properly, grade the disturbed area to original contours and stabilize.
- * Paid for as Temporary Filter Berm

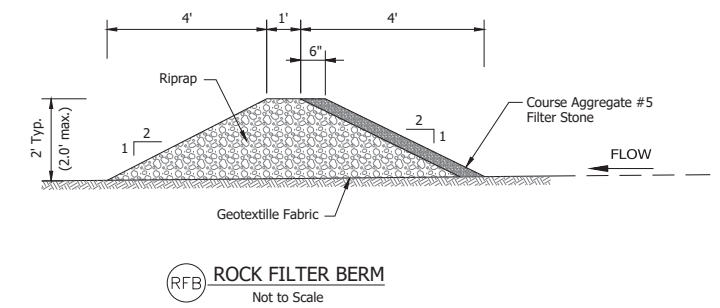

RFB ROCK FILTER BERM
Not to Scale

STANDARD INDOT DRAWINGS

- CD** TEMPORARY CHECK DAM, REVETMENT RIPRAP
Installation shall be per INDOT Standard Drawing 205-TECD-06.
- CE** TEMPORARY EROSION CONTROL PERIMETER CONSTRUCTION ENTRANCE
Installation shall be per INDOT Standard Drawing 205-TECD-12.

Date: Apr 04, 2024, 11:59am User Name: eobson
File: X:\Production\Files\2021\121-0031\194-00-00\CD\Erosion\EC_Details.dwg

RECOMMENDED FOR APPROVAL _____	DESIGN ENGINEER _____	DATE ____/____/____	INDIANA DEPARTMENT OF TRANSPORTATION	HORIZONTAL SCALE No Scale	BRIDGE FILE -
DESIGNED: _____ SMW	DRAWN: _____ ERO			VERTICAL SCALE -	DESIGNATION 2001940
CHECKED: _____ JAW	CHECKED: _____ SMW		EROSION/SEDIMENT CONTROL DETAILS	SURVEY BOOK	SHEETS 13 of 23
				CONTRACT B-42732	PROJECT 2001940

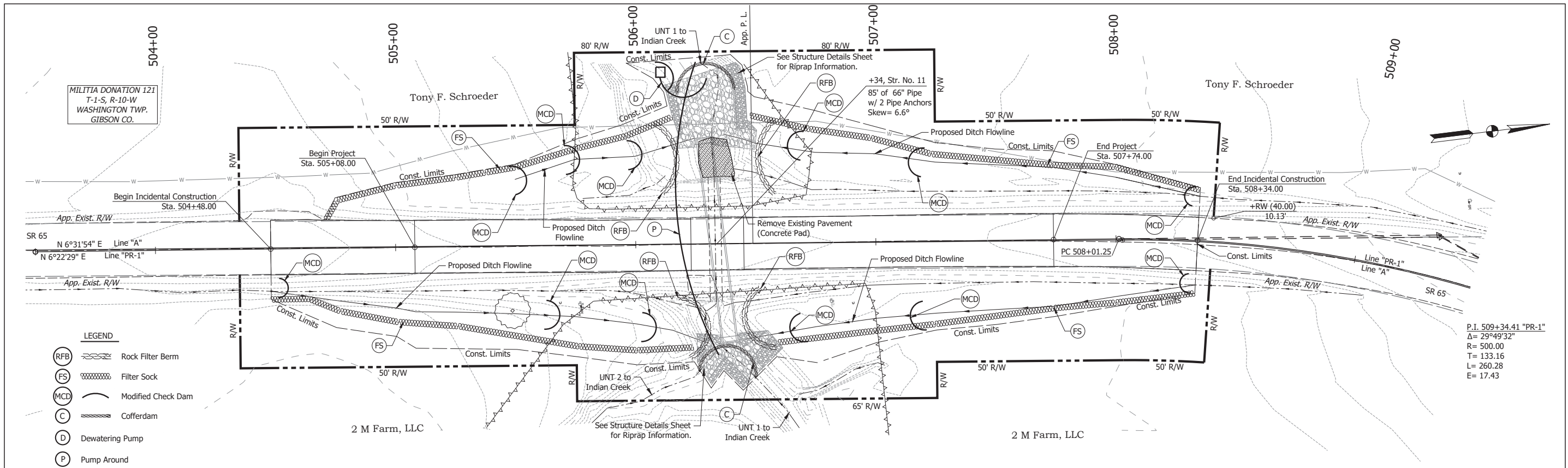

- LEGEND**
- (RFB) Rock Filter Berm
 - (FS) Filter Sock
 - (MCD) Modified Check Dam
 - (C) Cofferdam
 - (D) Dewatering Pump
 - (P) Pump Around

P.I. 509+34.41 "PR-1"
 $\Delta = 29^\circ 49' 32''$
 $R = 500.00$
 $T = 133.16$
 $L = 260.28$
 $E = 17.43$

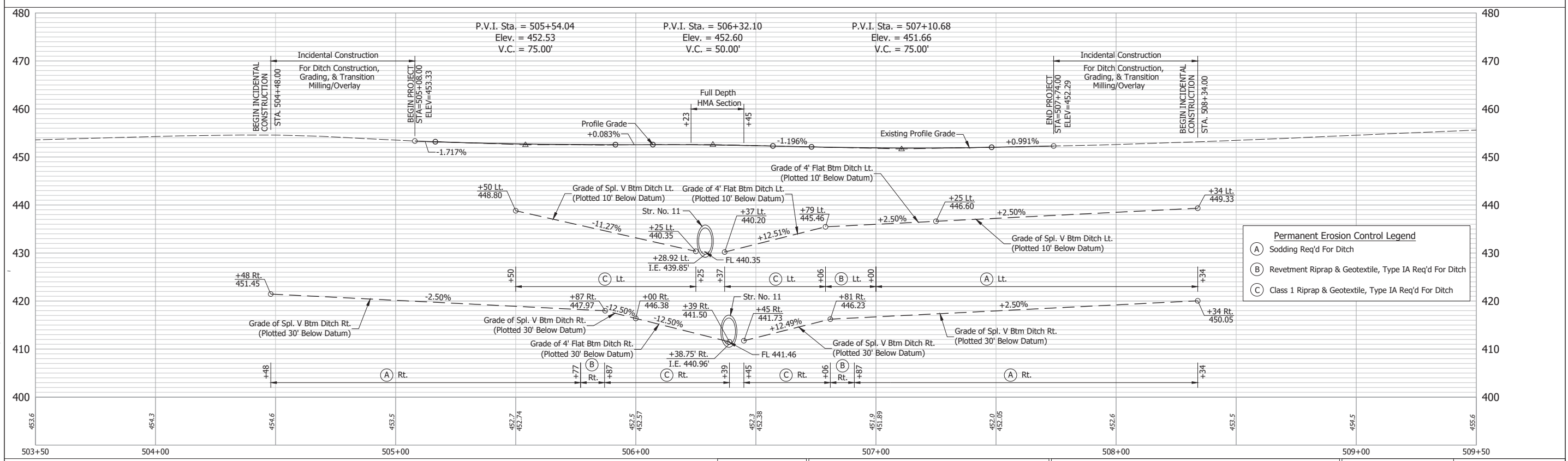

- Permanent Erosion Control Legend**
- (A) Sodding Req'd For Ditch
 - (B) Revetment Riprap & Geotextile, Type IA Req'd For Ditch
 - (C) Class 1 Riprap & Geotextile, Type IA Req'd For Ditch

- Notes:**
- 1) Station/Offset Toponotes, Benchmarks, & Right-of-Way Described from Line "A".
 - 2) See Geometric Tie-Up Sheet for Alignment Line "A" Information.
 - 3) All Stationing off Line "PR-1" Unless Otherwise Noted.
 - 4) Construction based off Line "PR-1"

RECOMMENDED FOR APPROVAL	DESIGN ENGINEER	DATE
DESIGNED: SMW	DRAWN: ERO	
CHECKED: JAW	CHECKED: SMW	

INDIANA DEPARTMENT OF TRANSPORTATION

EROSION/SEDIMENT CONTROL PLAN

HORIZONTAL SCALE	BRIDGE FILE
1"=20'	-
VERTICAL SCALE	DESIGNATION
1"=10'	2001940
SURVEY BOOK	SHEET
	14 of 23
CONTRACT	PROJECT
B-42732	2001940

Date: Apr 04, 2024, 11:59am User Name: eobson File: X:\Production\Files\2021\121-0033\194-00\CAD\Erosion\EC_Plan.dwg

Preliminary Design Plans

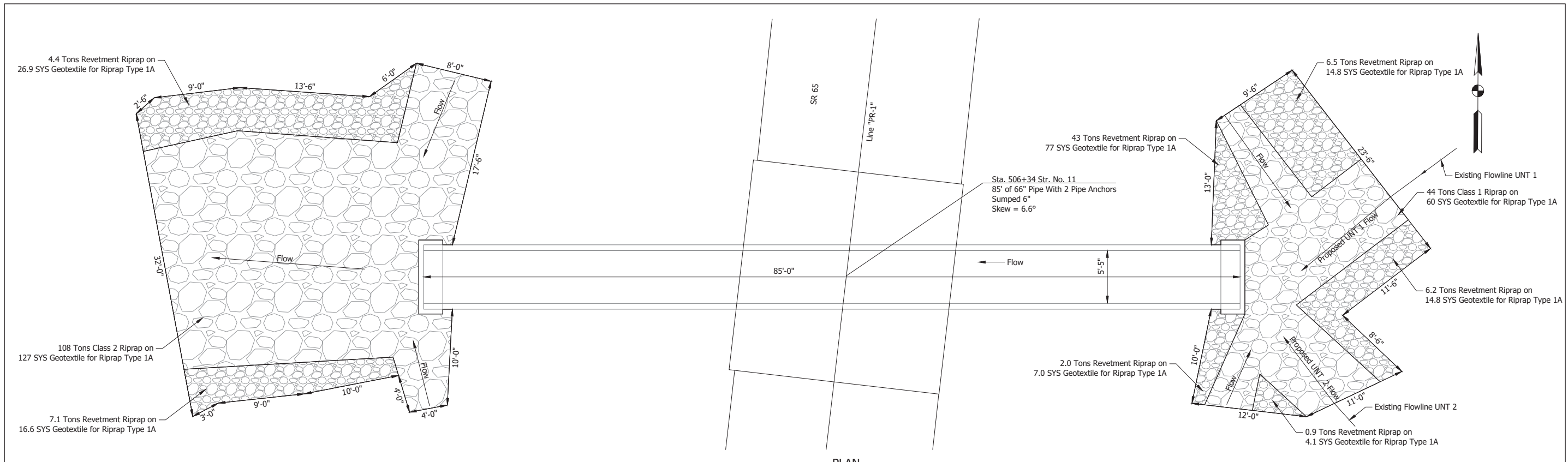

PLAN

HYDRAULIC INFORMATION

Drainage Area	128.6 acres
Q100 Discharge	144.12 cfs
Q100 Elevation	446.32 ft.
Q10 Velocity	12.33 ft./sec.

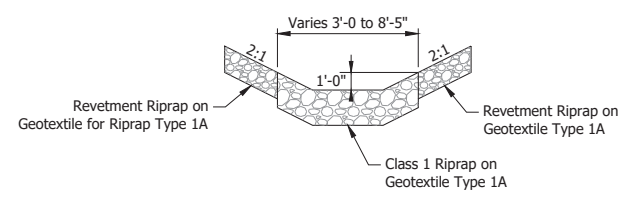

INLET RIPRAP

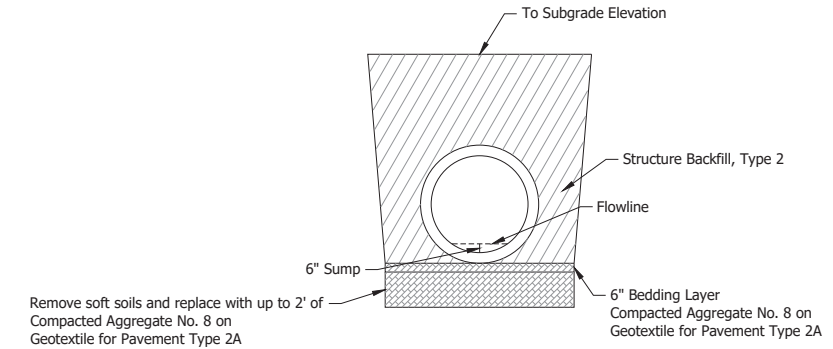

OUTLET/INLET ELEVATION

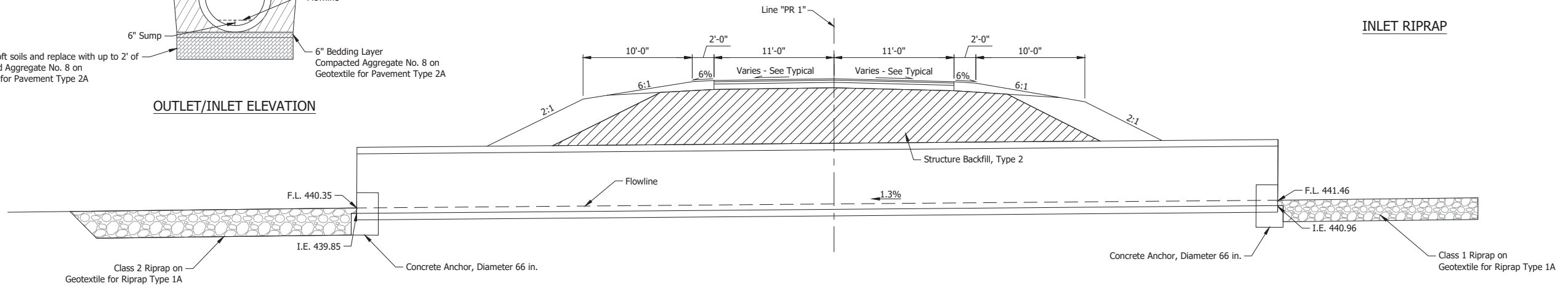

SECTION ALONG SKEW

- Notes:
- 1) Roadway Typical Dimensions & Slopes Labeled Perpendicular in Section View
 - 1) Location and Dimensions of Proposed Riprap is Approximate. Final Location of Riprap to be Field Verified and Approved by Engineer.

RECOMMENDED FOR APPROVAL	DESIGN ENGINEER	DATE
DESIGNED: SMW	DRAWN: ERO	
CHECKED: JAW	CHECKED: SMW	

INDIANA
DEPARTMENT OF TRANSPORTATION

STRUCTURE DETAILS

HORIZONTAL SCALE	BRIDGE FILE
1"=5'	-
VERTICAL SCALE	DESIGNATION
1"=5'	2001940
SURVEY BOOK	SHEET
	15 of 23
CONTRACT	PROJECT
B-42732	2001940

Date: Apr 04, 2024, 12:00pm User Name: eobson File: X:\Production\Files\2021\121-0033\194-00\CAD\Misc\DWG\Structure_Details.dwg

Preliminary Design Plans

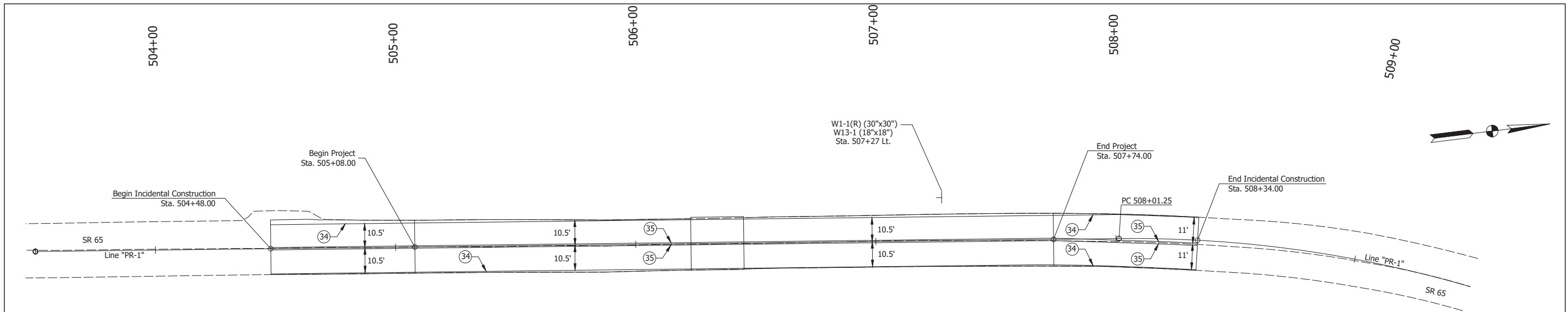

LEGEND

- ③④ Line, Paint, Solid, White, 6 in.
- ③⑤ Line, Paint, Solid, Yellow, 6 in.
- ┆ Ground Mounted Sheet Sign

PAVEMENT MARKING SUMMARY				
LOCATION		PAINT		*SNOWPLOWABLE RAISED PAVEMENT MARKERS, REMOVE
		LINE, SOLID, WHITE, 6"	LINE, SOLID, YELLOW, 6"	
FROM STATION	TO STATION	Ft.	Ft.	Ea.
Line "PR-1"				
504+48.00	508+34.00	772	772	10
TOTALS:		772	772	10

SIGN, SHEET, & SUPPORTS, REMOVE		
LOCATION	DESCRIPTION	QUANTITY (EACH)
507+27 Lt.	W1-1R W13-1P	1
TOTAL		1

SHEET SIGN & POST SUMMARY										
PLAN SHEET NO. / LINE	SIGN LOCATION (STA.)	SIGN CODE	SIGN	SIGN SIZE (IN. x IN.)	GROUND - MOUNTED SIGN AREA (Sq. Ft.)			SQUARE		REMARKS
					0.080	0.100	0.125	2-1/4 in. x 2-1/4 in. x 12 ga. (TYPE 1)		
					REINFORCED POST LENGTH (Ft.)		UNREINFORCED POST LENGTH (Ft.)			
Line "PR-1"	507+27 Lt.	W1-1(R) W13-1P	Turn Ahead Speed Advisory (20 mph)	30x30 18x18	6.25 2.25			14.00	14.00	
Total This Sheet					9.00			14.00		

*See USP for Additional Information.

Notes:
1) Transition Proposed Pavement Markings to Existing within Incidental Construction Limits

RECOMMENDED FOR APPROVAL _____	DESIGN ENGINEER _____	DATE: --/--
DESIGNED: _____ SMW	DRAWN: _____ ERO	
CHECKED: _____ JAW	CHECKED: _____ SMW	

INDIANA DEPARTMENT OF TRANSPORTATION	
PROPOSED PAVEMENT MARKINGS & SIGNS	

HORIZONTAL SCALE 1"=20'	BRIDGE FILE -
VERTICAL SCALE ---	DESIGNATION 2001940
SURVEY BOOK	SHEET 16 of 23
CONTRACT B-42732	PROJECT 2001940

Date: Apr 04, 2024, 12:00pm User Name: eobson File: X:\Production\Files\2021\121-003\194-00\1940\Signs & Pavement Markings.dwg

TEMPORARY PUMP-AROUND	
STATION	NO. REQ'D. (EACH)
Line "PR-1"	
506+34.00	1
TOTAL:	1

TEMPORARY FILTER BERM					
FROM STATION	TO STATION	LEFT	MEDIAN	RIGHT	TOTAL LENGTH (LFT)
Line "PR-1"					
506+00.00	507+00.00			X	70
506+00.00	507+00.00	X			70
TOTAL:					140

FILTER SOCK					
FROM STATION	TO STATION	LEFT	MEDIAN	RIGHT	TOTAL LENGTH (LFT)
Line "PR-1"					
504+48.00	506+34.00			X	180
506+34.00	508+34.00			X	175
504+48.00	506+34.00	X			155
506+34.00	508+34.00	X			195
TOTAL:					705

TEMPORARY CHECK DAM, REVETMENT RIPRAP							
FROM STATION	TO STATION	LEFT	RIGHT	NO. CHECKS (EACH)	REVETMENT RIPRAP (TONS)	FILTER STONE (TONS)	TEMPORARY GEOTEXTILE (SYS)
Line "PR-1"							
504+48.00	506+39.00	X		3	13.5	0.75	54.6
506+45.00	508+34.00	X		3	13.5	0.75	54.6
505+25.00	506+25.00	X		3	13.5	0.75	54.6
506+37.00	508+34.00	X		3	13.5	0.75	54.6
TOTALS:					54	3.0	219

PROJECT QUANTITIES	
No. 2 Stone : (2 Constr. Entrances, locations determined in field)	100 Ton
Mobilization & Demobilization for surface stabilization	2 Each
Sediment, Remove	40 cyd
*Concrete Washout (undisturbed locations, locations determined in field)	4 Each

*Not paid for directly

TEMPORARY SEED MIXTURE (0.75 ac)	
Temporary Seeding Mixture (200 lbs/Acre * 2 appl.)	300 lbs

TEMPORARY MULCH (0.75 ac)	
Temporary Mulch (2.5 Ton/Acre * 2 appl.)	4 Ton

FERTILIZER (0.75 ac)	
Temporary Fertilizer (0.2 Ton/Acre * 2 appl.)	0.3 Ton

PIPE MATERIAL TABLE		
INT. DES.	STRUCTURE NUMBER	11
	PIPE TYPE / SHAPE (CIR or DEF)	2/Cir.
	SMOOTH PIPE SIZE	66"
	CORRUGATED PIPE SIZE	
CONC.	RCP/RCHP (S)	CLASS II
	D 0.01 RATING	1000
PLASTIC PIPE	NON-REINFORCED CONCRETE PIPE, CLASS 3 (S)	
	CORRUGATED PE PIPE, TYPE S (S)*	
	PROFILE WALL (RIBBED) PE PIPE (S)*	
	PROFILE WALL (CLOSED) PE PIPE (S)*	
	SMOOTH WALL PE PIPE (S)* / MAXIMUM DR	
	CORRUGATED PP PIPE (S)	
CLAY	VITRIFIED CLAY PIPE, EXTRA STRENGTH (S)	
	CORRUGATED STEEL PIPE / PIPE-ARCH	FULLY BIT. PAVED & LINED (S)
		ZINC COATED (C)
CORRUGATED STEEL PIPE / PIPE-ARCH	ZINC COATED W/ BPI (C)	
	ALUM. COATED TYPE 2 (C)	
	ALUM. COATED TYPE 2 W/ BPI (C)	
	POLYMER PRECOATED GALVANIZED (C)	
	POLYMER PRECOATED GALVANIZED CORRUGATED STEEL PIPE TYPE 1A (S)	
	COR. ALUM. PIPE/ P-ARCH	CORRUGATED ALUM. ALLOY (C)
SPIRAL RIB STEEL PIPE	CORRUGATED ALUM. ALLOY W/ BPI (C)	
	ZINC COATED (SS)	
	ALUM. COATED TYPE 2 (C)	
	ALUM. COATED TYPE 2 W/ BPI (C)	
STRUCTURAL PLATE PIPE / PIPE-ARCH	POLYMER PRECOATED GALVANIZED (C)	
	STR. PLATE ALUMINUM ALLOY (C)	
	STR. PLATE ALUMINUM ALLOY W/ CFP (C)	
	STR. PLATE STEEL (C)	
	STR. PLATE STEEL W/ CFP (C)	

LEGEND	
PIPE MATERIAL	
RCP	Reinforced Concrete Pipe
RCHP	Reinforced Concrete Horizontal Elliptical Pipe
PE	Polyethylene
DR	Dimension Ratio
PVC	Polyvinyl Chloride
PP	Polypropylene
CORR	Corrugation
ALUM	Aluminum
STR	Structural
(LS)	Lock Seam Pipe Required
PIPE PROTECTION	
BPI	Bituminous Paved Invert
CFP	Concrete Field Paving
BIT	Bituminous
SHAPE	
CIR	Circular Pipe
DEF	Deformed Pipe
INTERIOR PROTECTION	
(S)	Smooth Pipe Material
(C)	Corrugated Pipe Material
(SS)	Semi-Smooth Pipe Material
PIPE SIZE	
Circular pipe is shown as diameter in inches	
Deformed pipe is shown as area in square feet	

* Refer to Standard Drawings 715-PHCL-20 through -22 for nominal diameter appropriate for pay item diameter.

** Tabulated thickness refers to top and side plates. For pipes and pipe-arches with a thickness less than .280 in., bottom plates shall be of next greater available thickness.

Date: Apr 04, 2024, 12:00pm User Name: eobson
File: X:\Production\Files\2021\121-0031\140-00\140\140\Misc\Tables.dwg

RECOMMENDED FOR APPROVAL _____ DESIGN ENGINEER	DATE	INDIANA DEPARTMENT OF TRANSPORTATION	HORIZONTAL SCALE	BRIDGE FILE
DESIGNED: _____ SMW	DRAWN: _____ ERO		No Scale	-
CHECKED: _____ JAW	CHECKED: _____ SMW	MISCELLANEOUS TABLES	VERTICAL SCALE	DESIGNATION
			-	2001940
			SURVEY BOOK	SHEETS
			17 of 23	
			CONTRACT	PROJECT
			B-42732	2001940

Preliminary Design Plans

EARTHWORK SUMMARY (Cu. Yards)								
LOCATION	EXCAVATION	UNSUITABLE MATERIAL	*EXCAVATION FOR RIPRAP	B-BORROW	*BENCHING	*BENCHING +25%	FILL	FILL +25%
LINE "PR-1"	610	85	310	85	290	365	435	545
TOTAL	610	85	310	85	290	365	435	545

*NOT TO BE MEASURED FOR PAYMENT

COMMON EXCAVATION	695 CYD
EXCAVATION FOR RIPRAP	310 CYD
B-BORROW	85 CYD
WASTE	385 CYD

WASTE	
Fill Available	1,210
Fill Required	- 910
Unsuitable Material	+ 85
	385

SODDING SUMMARY TABLE					
FROM STATION	TO STATION	LEFT	RIGHT	ACTUAL LENGTH	FOR DITCHES
				LFT	SYS
LINE "PR-1"					
504+48	505+77	X		129	94.9
506+87	508+34	X		147	108.1
507+00	508+34	X		134	98.5
TOTAL					302

TABLE OF R/W MARKERS					
LINE	STATION	OFFSET		NO.	
		LEFT	RIGHT		
"A"	104+35.00	50.00'		1	
	105+75.00	80.00'		1	
	105+75.00	80.00'		1	
	106+48.46	80.00'		1	
	107+25.00	80.00'		1	
	107+25.00	50.00'		1	
	P.C. 108+02.61	50.00'		1	
	108+40.00	50.00'		1	
	104+35.00		50.00'	1	
	105+75.00		50.00'	1	
	105+75.00		65.00'	1	
	107+25.00		65.00'	1	
	107+25.00		50.00'	1	
	P.C. 108+02.61		50.00'	1	
	108+40.00		50.00'	1	
TOTAL				15	

*PAVEMENT REMOVAL				
FROM STATION	TO STATION	LEFT	RIGHT	REMOVAL AREA
				SYS
LINE "PR-1"				
506+26.50	506+41.50	X		23.2
TOTAL				24

*Approximately 16' by 13' Concrete Pad at Downstream End of Structure 11

SEEDING TABLE	
0.76 Acres	
Mulched Seeding, R	3,653 SYS
Mob. & Demob. for Seeding	2 Each

STRUCTURE SUBGRADE IMPROVEMENTS				
STRUCTURE NO.	COMPACTED AGGREGATE, NO. 8	COMPACTED AGGREGATE, NO. 8	GEOTEXTILE FOR PAVEMENT TYPE 2A	COMMON EXCAVATION
	6"	12"		
	CYS	CYS	SYS	CYS
11	16.8		113.4	16.8
Undistributed		67.4	245.6	67.4
TOTALS:	85		359	85

RIPRAP SUMMARY TABLE							
FROM STATION	TO STATION	LEFT	RIGHT	ACTUAL LENGTH	REVTMENT RIPRAP	CLASS 1 RIPRAP	GEOTEXTILE FOR RIPRAP TYPE 1A
				LFT	TONS	TONS	SYS
LINE "PR-1"							
505+77	506+39	X		131	47.5	43.4	172.5
506+39	506+91	X		129	50.0	24.0	140.5
505+50	506+29	X		100	54.2	51.2	204.1
506+29	507+00	X		88	79.1	37.3	215.8
TOTAL					231	156	733

Date: Apr 04, 2024, 12:00pm User Name: eobson File: X:\Production\Misc\2021\121-0033\PR-02\GAD\Misc\DWG\Misc Tables.dwg

RECOMMENDED FOR APPROVAL _____	DESIGN ENGINEER _____	DATE: --/--
DESIGNED: _____ SMW	DRAWN: _____ ERO	
CHECKED: _____ JAW	CHECKED: _____ SMW	

INDIANA DEPARTMENT OF TRANSPORTATION

MISCELLANEOUS TABLES

HORIZONTAL SCALE	BRIDGE FILE
No Scale	-
VERTICAL SCALE	DESIGNATION
-	2001940
SURVEY BOOK	SHEETS
	18 of 23
CONTRACT	PROJECT
B-42732	2001940