

HISTORIC BRIDGE ALTERNATIVES ANALYSIS

BRIDGE NUMBER: P000-64-07069

DESIGNATION NUMBER: 2200175

ROUTE IDENTIFICATION AND FEATURE CROSSED:
Wilson Road over Dunes Creek

COUNTY: Porter



**REVIEW OF DESIGN PLANS/DOCUMENTS
REVIEWED FOR DESIGN FEATURES**

(Bridge Reviewer)

Randy Henderson

BY: _____

DATE:

EGIS BLN USA, INC.

PROJECT LOCATION: Dunes State Park, Westchester Township, Porter County, Indiana

PREPARED BY: Chris Beres, PE
Hanson Professional Services, Inc.

DATE: October 2, 2023

This bridge was evaluated by personnel from the Indiana Department of Transportation (INDOT) Bridge Design Unit, the District Office and the designer. The attached Draft Historic Bridge Alternatives Analysis has been reviewed by the INDOT Bridge Design Unit and Cultural Resources Office for thoroughness of the rehabilitation option and compliance with INDOT design policies. Concurrence by INDOT with the proposed Scope of Work does not constitute Final Approval the Historic Bridge Alternatives Analysis. This draft HBAA may now be distributed to the historic consulting parties for review.

TABLE OF CONTENTS

- I. Existing Structure Data
- II. Existing Conditions
- III. Purpose and Need
- IV. Alternatives
- V. Minimization and Mitigation
- VI. Preliminary Preferred Alternative
- VII. Appendices
 - Appendix A: Alternatives Analysis Table
 - Appendix B: Maps
 - Appendix C: Photographs
 - Appendix D: Graphics/Drawings
 - Appendix E: Cost Estimates
 - Appendix F: Bridge Existing Conditions and Applicable Design Criteria Table
 - Appendix G: Field Check Meeting Minutes

I. EXISTING STRUCTURE DATA

A. Identification/History

Bridge No.: P000-64-07069

Project Location: Wilson Road over Dunes Creek, Dunes State Park, INDOT
LaPorte District.

Designation No.: 2200175

Year Built: 1934

Years Repaired: 1951 (unknown bridge work)

Most Recent Inspection Date: October 7, 2022

Average Daily Traffic:

- Current traffic counts are not available for this roadway. Based on 2004 traffic counts and available park visitation data, it is assumed that the traffic counts are between 100 – 400 vehicles per day.

Percentage of Commercial Vehicles: 0% (assumed)

Low volume road?: Yes

Functional Classification: Local Road

Detour Route: N/A. No detour route exists at this time. Reconstruction of Tremont Rd and State Park Rd to provide a detour route is explored in the Alternatives section of this report.

Load Rating:

- Load rating information is provided from the Bridge Rating Application Database of Indiana (BRADIN), which is the governing system for all bridge load ratings in Indiana. Legal or routine permit loads for the design vehicle (HS 20) do not produce a load rating factor (RF) less than 1.0, so load posting of the bridge is not required in accordance with INDOT Bridge Inspection Manual 3-6.0.
- HS 20 Legal RF = 1.188; Load Capacity = 42 Tons

Sufficiency Rating: 30.3 (out of 100)

National Register of Historic Places Status: Eligible

Historic Bridge Prioritization Status: Select

Historic Character Defining Features:

- The bridge displays the use of non-standard decorative railing combined with other aesthetic treatments to provide notable ornamentation.

B. Structure/Dimensions

Surface Type: Asphalt Overlay

Out to Out of Copings: 30'-0"

Out to Out of Bridge Floor: 160'-0"

Clear Roadway Width: 22'-4"

Number of Lanes on Structure: 2

Skew: 0°

Type of Superstructure: Cast in Place Concrete Box Beam Bridge

Spans: 8 spans @ 20'-0"

Type of Substructure/Foundation: Concrete Columns on Concrete Spread
Footings

Seismic Zone: 1

C. Appurtenances

Bridge Railing: Architectural concrete railing on both sides of bridge. 2'-0" height measured from sidewalk surface.

Curbs: 0'-7½" curb at sidewalk on both sides of bridge.

Sidewalk: 2'-11" width, 0'-7½" height, sidewalk on each side of bridge.

Utilities:

- Existing sewer line attached to the north coping of the bridge.
- Existing fiber optic line attached to north coping of bridge in gray conduit above sewer pipe.
- Underground water utilities exist in the project area.
- Underground telecommunication utilities exist in the project area.

Railroad: The Northern Indiana Commuter Transport District (NICTD) operates a commuter rail line located approximately 0.12 miles south of the intersection of State Park Rd and Tremont Rd. No impacts are anticipated.

D. Approaches

Roadway Width: 22'-0"

Surface Type: Asphalt east of bridge, concrete west of bridge.

Guardrail: None

II. EXISTING CONDITIONS

Photos of the existing conditions can be found in Appendix C. Condition ratings range from 0 to 9, with 0 indicating a failed structure and 9 indicating no deficiencies. The existing structure has 8 spans identified by the letters A through H. A drawing of the existing structure can be found in Appendix D.

A. Bridge Deck

- General: The bridge deck is in serious condition overall (condition rating 3 out of 9).
- Overlay: There is an asphalt (HMA) overlay on the bridge deck.
- Surface Condition: The HMA wearing surface has a large amount of cracking throughout the entire surface. Some of the cracks have been sealed with crumb rubber. It is unknown if there is a deck membrane between the HMA wearing surface and concrete bridge deck.
- Underside Condition: There is cracking with heavy efflorescence in all spans of the deck. Span F has heavy map cracking that is worse than all other spans and contains significant leaking efflorescence. Span F was sounded at the last inspection and significant delamination was found.
- Joints: The condition of the bridge joints is unknown as they are covered by HMA.
- Drainage: The roadway is crowned at the centerline of the structure, and the sidewalks are sloped toward the roadway. There are deck drains in every span on both sides of the structure. The deck drains are in fair condition (rusting with no other issues). There are no drainage issues on the bridge deck.
- Bridge Railing: There is some cracking and chipping throughout both railings. The concrete bridge railings are 2'-0" tall. Bridge railing design criteria is controlled by the level of crash testing that the railing has been tested for. Due to the age of the existing railing, it is not defined by a standard test level. An existing railing may remain in place if there is no history of crashes, which is the case for this location. A level two design exception may be utilized to document the design decision to keep

the existing railing in place. A level two design exception applies to elements that have an impact on road safety but do not require formal justification and approval.

- Sidewalks: There is a 2'-11" wide sidewalk on each side of the structure. There is some cracking throughout each of the sidewalks. Sections of each sidewalk appear to have been patched with concrete.

B. Superstructure

- General: The superstructure is in serious condition overall (condition rating 3 out of 9). There is beam end cracking on the majority of the beams with efflorescence. Beams one and two in span B have spalling with exposed reinforcement. Some of the exposed reinforcement has been patched with grout. The patching did not restore the original cross section. In span F, all beams are map cracked, longitudinal cracking in the bottom of the beams and vertical cracking in the beams, with heavy efflorescence in the cracks. Sounding of the beams in span F found significant delamination.

C. Substructures and Foundations

- General: The substructure is in poor condition overall (condition rating 4 out of 9). There is minor concrete column and pier cap cracking. There are minor vertical cracks in the abutment walls. Abutment 1 has a spall with exposed reinforcement near its base. The east outside ends of caps at top of all piers have efflorescence and spalling. West outside ends of caps at top of piers 2 and 6 have heavy efflorescence and spalling. Pier 3, column 5 is spalled and cracked at the base of the column. Pier 6, column 5 has spalling at the base.
- Scour: The structure is stable for scour conditions. The main channel flows at the east end of the structure; it is a swampy area with slow velocity. There is no riprap under or around the bridge. There are large amounts of sand under each span.

D. Approaches

- General: There are concrete approach slabs paved over with HMA. The approach pavement (asphalt east of the bridge and concrete west of the bridge) is in satisfactory condition overall. There are curb ramps that meet current standards west of the bridge.

E. Slopedwalls

- There are no slopedwalls on the structure.

III. PURPOSE AND NEED

The need for this project is due to the deteriorated condition of the existing bridge. The bridge was originally constructed in 1934 and received rehabilitation work in 1951. The extent of the rehabilitation is unknown. The superstructure and deck are rated 3 out of a possible 9; a rating of 3 indicates “serious condition”. There are 8 spans identified by the letters A through H. The deck has heavy cracking throughout all spans. There is heavy cracking in the concrete beams of all spans with more advanced cracking and spalling in spans E and F. There are 2 beams in span B that have spalled concrete with exposed steel reinforcement. The existing concrete piers and abutments have a current rating of 4, “poor condition”. There is cracking and spalling in the piers and abutments with exposed reinforcement in abutment 1, pier 2, pier 3, and pier 6. The most recent bridge inspection report dated October 7, 2022, indicates an unofficial sufficiency rating of 30.3 out of a possible 100.

Secondary to the primary need for this project is the need to maintain access at all times to the campground that the structure services. The campground is a crucial revenue source not only for the Dunes State Park, but also funds many other State Park facilities.

The primary purpose of this project is to provide a crossing of Dunes Creek such that all structural elements have a condition rating of at least 7 out of 9; a rating of 7 indicates “good” condition.

The secondary purpose of this project is to maintain access at all times to the campground serviced by the bridge.

IV. ALTERNATIVES

A. No Build/Do Nothing

This alternative allows the existing structure to remain in place with no improvements. No federal funds would be expended, and no action would occur. This alternative is an avoidance alternative.

This alternative does not address the purpose and need for the project. This alternative does not improve the condition of any of the structural elements of the structure. Without repairs, the existing elements will continue to deteriorate, and the service life expectancy remains 5-10 years until repairs are required. If the bridge were closed, there currently is no viable detour route without extensive improvements to State Park Road and Tremont Road. This alternative is feasible; however, it is not prudent as it does not address the project’s purpose and need.

B1a. Rehabilitation for Continued Vehicular Use (two-lane option) Meeting Secretary of Interior's Standards for Rehabilitation – Deck Overlay

This alternative would involve rehabilitating the existing structure for continued vehicular use for two lanes (one in each direction) across the bridge.

Scope of bridge work:

- Bridge Deck
 - Removal of the asphalt overlay on the bridge deck.
 - Full and partial depth patching of the deck as required.
 - Concrete overlay on the bridge deck.
 - Sidewalk
 - Patch as required.
 - Epoxy inject cracks as required.
 - Surface seal entire sidewalk.
 - Concrete Bridge Railing
 - Patch as required.
 - Surface seal entire railings.
- Superstructure
 - Patch as required.
 - Epoxy inject cracks as required.
- Substructure
 - Patch piers and abutments as required.
 - Epoxy inject cracks in piers and abutments as required.
 - Fiber wrap all piers.
- Scour: Place scour protection around the piers and abutments per recommendations of the scour analysis.
- Approaches:
 - Replace the bridge approach slabs.
 - Transition mill the approach pavement as required.

The proposed scope of work would fall under INDOT's design criteria for a historic bridge on a low-volume road (IDM 412-5.03). A level one design exception would be required for ADA compliance of the existing sidewalk. The minimum sidewalk width to meet ADA compliance is 5'-0", which is not satisfied by the existing 2'-11" sidewalks (see Appendix F). This would be coordinated through the Technical Advisory Committee.

Maintenance of Traffic: Two options for Maintenance of Traffic have been analyzed for this alternative.

- Phased construction maintaining one-lane, two-way of traffic on the structure with temporary signals. This is not feasible due to the cross section of the structure. Even assuming that the existing sidewalks are removed and used as part of the travel lane during construction, it is not possible to attain a minimum clear roadway width (10' travel lane, 1' shoulders = 12' clear roadway width) on the structure. The maximum achievable clear roadway width is 9'-9½". See Appendix D for conceptual MOT typical sections. Due to the number of large trucks, trailers, and campers that utilize the road to get to the campground, it is not safe to recommend a design exception for clear roadway width in this scenario. As this MOT option is not feasible, it will not be considered further.
- Detour option. Currently there is no way to detour traffic to the park campground. There are two roads that are no longer in service that could feasibly be reconstructed as part of the project to provide a detour; 0.75 miles of State Park Rd from N SR 49 Bypass to Tremont Rd, and 0.37 miles of Tremont Rd from State Park Rd to Wilson Rd. These roadways are of substandard width and nearly impassable in their current state. This reconstruction work would require right-of-way acquisition and create additional environmental impacts that are discussed below. See Appendix D for a map of proposed work and detour. Another detour route, US 12 to Tremont Rd, was considered but determined not to be feasible at the initial field check meeting due to the extensive road reconstruction and the need to reestablish an at-grade railroad crossing. A graphic of this detour is also provided in Appendix D. See Appendix G for the initial field check meeting minutes.

Right-of-Way and Environmental Impacts:

- Impacts due to road reconstruction: permanent right-of-way is required for this alternative due to the detour. The National Park Service owns the right-of-way south of the centerline of State Park Road, meaning right-of-way would need to be purchased for the entire 0.75 miles of road to be reconstructed, or roughly 2.75 acres of right-of-way. Significant environmental impacts will be incurred due to rehabilitating the roads. The estimated area of environmental impacts due to clearing right-of-way and regrading is approximately 5.5 permanent acres. Approximately 0.13 acres of wetland impacts are anticipated.
- Impacts due to bridge work: No additional right-of-way is required for the bridge work. The estimated area of environmental impacts (soil disturbance) due to the bridge work is approximately 0.5 temporary acres and 0.1 permanent acres. Approximately 50 lineal feet of permanent impacts are anticipated to Dunes Creek

due to scour protection placement under the structure. Approximately 0.35 acres of wetland impacts are anticipated.

- Additional impacts: A new park entrance gatehouse will need to be constructed at the intersection of State Park Rd and N State Rd 49 Bypass. To access the campground today, vehicles drive north on N State Rd 49 Bypass past State Park Rd before reaching the park entrance gatehouse. If State Park Road is reconstructed, vehicles would not be passing a gatehouse to enter the park, so a new one must be constructed. The cost of this gatehouse is not considered in the construction estimate below.

Construction Cost Estimate: the estimated construction cost of this alternative is approximately \$6,460,000. Approximately 65% of this cost is due to the road reconstruction for the detour route. See Appendix E for detailed cost estimate. The expected service life of the rehabilitated structure is 15 years before additional maintenance is required, with superstructure elements rated 5 out of 9, and substructure elements rated 7 out of 9.

This alternative does not fully address the project purpose and need as the superstructure elements will not achieve a condition rating of at least a 7 out of 9. In Span B, the spalling and exposure of reinforcement of the beams are extensive enough that it is not possible to restore the cross section of the beam such that they can be rated above a 5 out of 9 with the methods outlined in this alternative. In Span F, the delamination in the superstructure is significant enough that it would not be possible to raise the condition rating above a 5 with the methods in this alternative. Additionally, significant impacts are caused by the reconstruction of the detour routes. Therefore, this alternative is not prudent.

B1b. Rehabilitation for Continued Vehicular Use (two-lane option) Meeting Secretary of Interior's Standards for Rehabilitation – Deck Overlay and Replacement of Span B & F

This alternative would involve rehabilitating the existing structure for continued vehicular use for two lanes (one in each direction) across the bridge. As described below, it includes more extensive work to the superstructure than Alternative B1a in order to achieve a higher condition rating.

Scope of bridge work:

- Bridge Deck
 - Removal of the asphalt overlay on spans A, C, D, E, G, and H.
 - Full and partial depth patching of spans A, C, D, E, G, and H as required.
 - Concrete overlay on the entire bridge deck.

- Sidewalk (Spans A, C, D, E, G, and H):
 - Patch as required.
 - Surface seal entire sidewalk.
- Concrete Bridge Railing (Spans A, C, D, E, G, and H)
 - Patch as required.
 - Surface seal entire railings.
- Superstructure
 - Replace Span B and Span F. The top side of the bridge (deck, sidewalk, and railings) will match the existing structure's dimensions, while the underside of the bridge (beam dimensions) may differ slightly depending on constructability constraints.
 - Patch as required.
 - Epoxy inject cracks as required.
- Substructure
 - Patch piers and abutments as required.
 - Epoxy inject cracks in piers and abutments as required.
 - Fiber wrap all piers.
- Scour: Place scour protection around the piers and abutments as required per recommendations of the scour analysis.
- Approaches;
 - Replace the bridge approach slabs.
 - Transition mill the approach pavement as required.

The proposed scope of work would fall under INDOT's design criteria for a historic bridge on a low volume road (IDM 412-5.03). A level one design exception would be required for ADA compliance of the existing sidewalk. The minimum sidewalk width to meet ADA compliance is 5'-0", which is not satisfied by the existing 2'-11" sidewalks (see Appendix F). This would be coordinated through the Technical Advisory Committee. After construction, all structural elements are expected to be rated at a 7 out of 9.

Maintenance of Traffic: The maintenance of traffic schemes analyzed for this alternative are the same as those analyzed in Alternative B1a above. Refer to Alternative B1a for MOT alternatives.

Right-of-Way and Environmental Impacts: the right-of-way and environmental impacts are the same as those in Alternative B1a above. Refer to Alternative B1a for right-of-way and environmental impacts.

Construction Cost Estimate: the estimated construction cost of this alternative is approximately \$6,780,000. Approximately 60% of this cost is due to the road

reconstruction for the detour. See Appendix E for detailed cost estimate. The expected service life of the structure is 25 years before additional maintenance is required.

This alternative satisfies the project purpose and need and is feasible. This alternative is not prudent due to the significant impacts caused by the reconstruction of the detour routes. The right-of-way purchase from the National Park Service and additional environmental permitting will require significant time and cost prior to construction. The relocation of the park entrance would add further environmental impact and construction cost.

B2. Rehabilitation for Continued Vehicular Use (two-lane option) NOT Meeting Secretary of Interior's Standards for Rehabilitation

Since alternative B1b meets the project purpose and need, there is no reason to explore an alternative that would not meet the Secretary of Interior's Standards for Rehabilitation, as such an alternative would substantially diminish the bridge's historic integrity without a meaningful engineering gain. Additionally, this alternative would not be prudent for the same reasons as those of Option B1b and will not be discussed further.

C. Rehabilitation for Continued Vehicular Use (one-way pair option) Meeting Secretary of Interior's Standards for Rehabilitation

This alternative would involve rehabilitation of the existing structure and construction of a new bridge and new approaches adjacent to it. The scope of the rehabilitation of the existing bridge would match that outlined in alternative B1b. The new structure would be a multi-span prestressed, reinforced concrete structure, or steel structure adjacent to the existing bridge. The structure type will be determined based on cost effectiveness and constructability constraints. The proposed bridge cross section would have a clear roadway width of 28'-0" and will meet all Level One design criteria. The width of the structure allows for a future second lane of traffic if bi-directional traffic should become desired in the future. Once construction is completed, the new bridge will carry one-way vehicular traffic and pedestrian traffic (one 12'-0" travel lane, 2'-0" shoulders, and a 12'-0" shared use path) and the existing bridge will carry one-way traffic in the opposite direction (one 12'-0" travel lane with 5'-2" shoulders).

The proposed scope of work for the existing bridge would fall under INDOT's design criteria for a historic bridge on a low volume road (IDM 412-5.03). No level one design exceptions are anticipated (see Appendix F). A level 2 design exception will be utilized for the existing bridge railing test level. A level two design exception will be approved because there is no history of crashes related to the railing and the existing condition is being maintained. After construction, all structural elements are expected to be rated at a

7 out of 9. The proposed scope of work for the new structure would fall under INDOT's design criteria for a Rural Local Road (IDM Figure 53-5).

To maintain traffic during construction, the new bridge will be completely constructed while the existing bridge remains open at its current capacity. After the new bridge is completed, 2-lane 2-way traffic and pedestrian traffic (two 11'-0" travel lanes, 1'-0" shoulders, 4'-0" pedestrian path) will be opened on the new bridge while the existing bridge is closed for the required rehabilitation work.

A temporary bypass structure was considered in lieu of the maintenance of traffic alternative described in the paragraph above, but it is not considered prudent. The temporary structure would not be significantly less costly than a permanent structure. In addition, when maintenance is required on the historic bridge in the future (estimated in 25 years), a temporary bypass structure would need to be constructed again, as there is no viable detour route to access the campground (see Alternative B1a.)

No permanent or temporary right-of-way is required for this alternative. The estimated area of environmental impacts (all soil disturbance) is approximately 0.9 acres of temporary impact, and 1.0 acre of permanent impact. Approximately 250 lineal feet of temporary impacts are anticipated to Dunes Creek. Approximately 100 lineal feet of permanent impacts are anticipated due to placement of scour protection. Approximately 1.0 acres of wetland impacts are anticipated.

Construction Cost Estimate: The estimated construction cost of this alternative is \$5,570,000. See Appendix E for detailed cost estimate. The expected service life of the existing structure is 25 years before additional maintenance is required. The expected service life of the new structure is 75 years.

This alternative fully addresses the purpose and need of this project. This alternative meets the minimum design standards in the Indiana Design Manual and the Secretary of the Interior's Standards for Rehabilitation without the use of level one design exceptions. As stated earlier, a level two design exception will be utilized to document the decision to keep the existing bridge railing in place. There will not be any design exceptions required for the new bridge. This alternative is considered feasible and prudent and satisfies the identified purpose and need.

V. MINIMIZATION AND MITIGATION

A. Minimization

For the preferred alternative, efforts to minimize impacts to the historic bridge include:

- **Maintaining Historic Aesthetics:** The existing bridge railings will be maintained on the historic bridge. For any spans that may be replaced, the new bridge railings will match the existing railings. Likewise, any sidewalk that is replaced will match the existing sidewalk.
- **Similar Materials:** Patching materials will utilize concrete mixes that resemble the appearance of the existing concrete to provide uniformity between the new and patched concrete. Likewise, spans that may be replaced will also utilize concrete mixes that resemble the appearance of the members that are being replaced. Piers that are fiber wrapped will be wrapped in a similar color to the existing concrete.

B. Bridge Marketing

Bridge Marketing is not required for this Select Bridge.

C. Mitigation

Consultation with the Indiana State Historic Preservation Officer (SHPO) will take place to determine if photo documentation of the existing bridge is required before construction activities commence. Rehabilitation plans will be provided to the Indiana SHPO at 30%, 60%, and 90% (final plans) completion for review and concurrence. Since the preferred alternative involves a bypass of the historic bridge, the plan submittals will include a site plan and design of the new bridge and the historic bridge. The purpose of these reviews is to evaluate the design and proximity of the new bridge in relationship to the historic bridge, ensure compliance with the Secretary of Interior's Standards for Rehabilitation, and to incorporate context sensitive design features, where practicable.

VI. PRELIMINARY PREFERRED ALTERNATIVE

Alternative C – Rehabilitation for Continued Vehicular Use (one-way pair option) Meeting Secretary of Interior's Standards for Rehabilitation is considered feasible and prudent and is the preferred alternative for this project.

See Appendix A for the Alternatives Analysis Table.

Appendix A: Alternatives Analysis Table

Alternative	Meets Project Purpose & Need?	Construction Cost	ROW Amount & Cost	Total Cost	Other Factors	Feasible & Prudent?
A - No Build/Do Nothing	No	None	None	None	Deterioration of the superstructure would continue and lead to eventual closure of the bridge.	This alternative is not prudent because it does not meet the project purpose and need.
B1a - Rehabilitation for Continued Vehicular Use (two-way option) - Deck Overlay	No	\$6,460,000	2.75 Acres. \$75,000	\$6,535,000	Historic Bridge Elements will be reused. A level one design exception is required for ADA compliance. Tremont Rd. and State Park Rd. will have to be reconstructed to provide a detour route. Reconstruction of State Park Rd. would require purchase of ROW from the National Park Service which would be a time consuming and expensive process. A new park gatehouse will have to be built before the intersection of State Park Rd. and N SR 49 Bypass. 5.5 acres of permanent impacts and 0.5 acres of temporary impacts are anticipated. Approximately 50 lineal feet of permanent stream impacts are anticipated. 0.48 acres of wetland impacts are anticipated.	This alternative is feasible; however it is not prudent because it does not meet the project purpose and need.
B1b - Rehabilitation for Continued Vehicular Use (two-way option) - Deck Overlay and Replacement of Span B & F	Yes	\$6,780,000	2.75 Acres. \$75,000	\$6,855,000	Historic Bridge Elements will be reused or recreated. A level one design exception is required for ADA compliance. Tremont Rd. and State Park Rd. will have to be reconstructed to provide a detour route. Reconstruction of State Park Rd. would require purchase of ROW from the National Parks Service which would be an extremely time consuming and expensive process. A new park gatehouse will have to be built before the intersection of State Park Rd. and N SR 49 Bypass. 5.5 acres of permanent impacts and 0.5 acres of temporary impacts are anticipated. Approximately 50 lineal feet of permanent stream impacts are anticipated. 0.48 acres of wetland impacts are anticipated.	This alternative is feasible; however it is not prudent because the extensive ROW acquisition and cost, the extensive coordination and time required as part of purchasing ROW from the National Park Service, and extensive environmental impacts caused by constructing the detour route.
B2 - Rehabilitation for Continued Vehicular Use (two-way option)	N/A	N/A	N/A	N/A	N/A	N/A
C - Rehabilitation for Continued Vehicular Use (one-way pair option)	Yes	\$5,570,000	None	\$5,570,000	Historic Bridge Elements will be reused or recreated. Level 2 design exception for bridge railing is anticipated. 0.6 acres of permanent impacts and 1.0 acre of temporary impacts are anticipated. Approximately 250 lineal feet of temporary and 100 lineal feet of permanent impacts to Dunes Creek are anticipated. Approximately 1.0 acre of wetland impacts are anticipated.	This alternative is feasible and prudent.

Appendix B: Maps



**Aerial Photography from 2013-2018
Showing the Project Location**

**Wilson Road over Dunes Creek
Porter County, Indiana
Des. No. 2200175**

 Project Area

Map Source: Esri and IndianaMAP, 2023



Created 6/15/2023



Portion of the USGS 7.5' Series
 Dune Acres, Indiana Topographic Quadrangle
 Showing the Location of the Project Area

Wilson Road over Dunes Creek
 Porter County, Indiana
 Des. No. 2200175

 Project Area



Map Source:
 Esri and IndianaMAP, 2023

Created 6/15/2023

Appendix C: Photographs



Photo: 1
Vantage Point: Under structure just north of Span E
Direction: Looking southwest
Description: North elevation



Photo: 2
Vantage Point: East of bridge
Direction: Looking west
Description: East approach



Photo: 3
Vantage Point: East side of bridge
Direction: Looking west
Description: Bridge deck, north Sidewalk, north bridge rail



Photo: 4
Vantage Point: North side of bridge deck
Direction: Looking north
Description: Typical deck drain



Photo: 5
Vantage Point: bridge deck
Direction: Looking south
Description: South sidewalk patching



Photo: 6
Vantage Point: Bridge deck
Direction: Looking west
Description: South bridge railing and sidewalk



Photo: 7
Vantage Point: Bridge deck
Direction: Looking south
Description: Chipped section of south bridge railing



Photo: 8
Vantage Point: Bridge deck
Direction: Looking northwest
Description: North sidewalk patch



Photo: 9
Vantage Point: Bridge deck
Direction: Looking southwest
Description: South sidewalk chipping



Photo: 10
Vantage Point: Bridge deck
Direction: Looking north
Description: North sidewalk spalling



Photo: 11
Vantage Point: Bridge deck
Direction: Looking west
Description: Northwest curb ramp and bridge railing transition



Photo: 12
Vantage Point: West approach
Direction: Looking south
Description: Trail 2 trailhead



Photo: 13
Vantage Point: Under Span A
Direction: Looking southwest
Description: Abutment 1



Photo: 14
Vantage Point: Just north of Span A under bridge
Direction: Looking west
Description: Utilities through Abutment 1



Photo: 15

Vantage Point: Under Span A

Direction: Looking southwest

Description: West side of Pier 2, typical beam condition of Span A



Photo: 16

Vantage Point: Under Span B

Direction: Looking southwest

Description: East side of pier 2, Span B beam spalling and patching



Photo: 17

Vantage Point: Under Span B

Direction: Looking west

Description: Typical underside deck condition Span B



Photo: 18

Vantage Point: Under Span B

Direction: Looking west

Description: Beam delamination and spalling Span B



Photo: 19

Vantage Point: Under structure just south of Span C

Direction: Looking northwest

Description: Pier 3 south column spalling



Photo: 20

Vantage Point: Under Span F

Direction: Looking southwest

Description: Span F beam and deck underside spalling and efflorescence,
Pier 6 east face



Photo: 21

Vantage Point: Under structure just south of Span E

Direction: Looking northeast

Description: Pier 6 spalling and beam efflorescence



Photo: 22

Vantage Point: Under structure just south of column 6

Direction: Looking north

Description: Pier 6 south column spalling



Photo: Photo 23

Vantage Point: Under structure just north of Span H

Direction: Looking southeast

Description: Abutment 9



Photo: 24

Vantage Point: Under Span H

Direction: Looking south

Description: Span H typical underside condition, Pier 8

Appendix D: Graphics/Drawings

Alternative B Phased Construction MOT

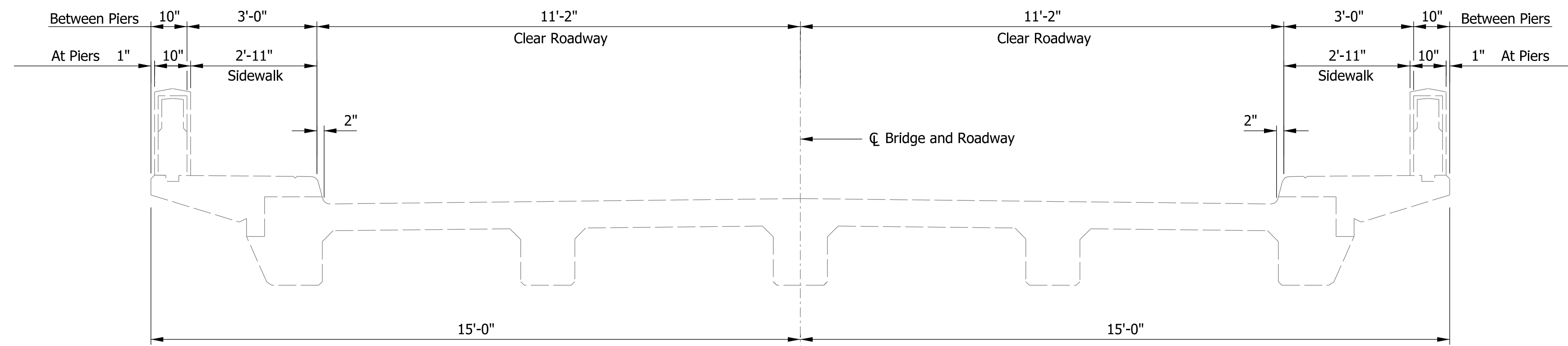

EXISTING SECTION
Scale: 1/2" = 1'-0"

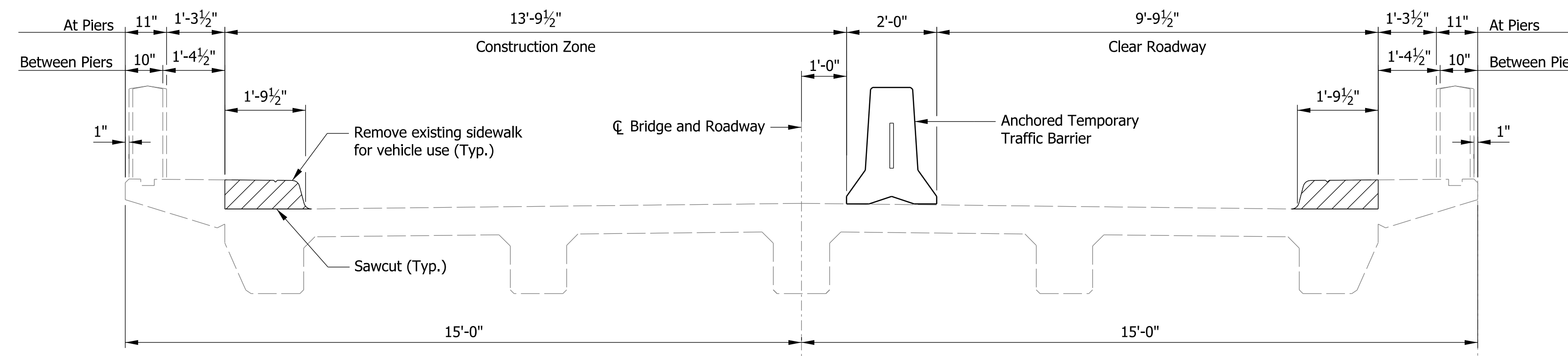

PHASE 1 SECTION
Scale: 1/2" = 1'-0"

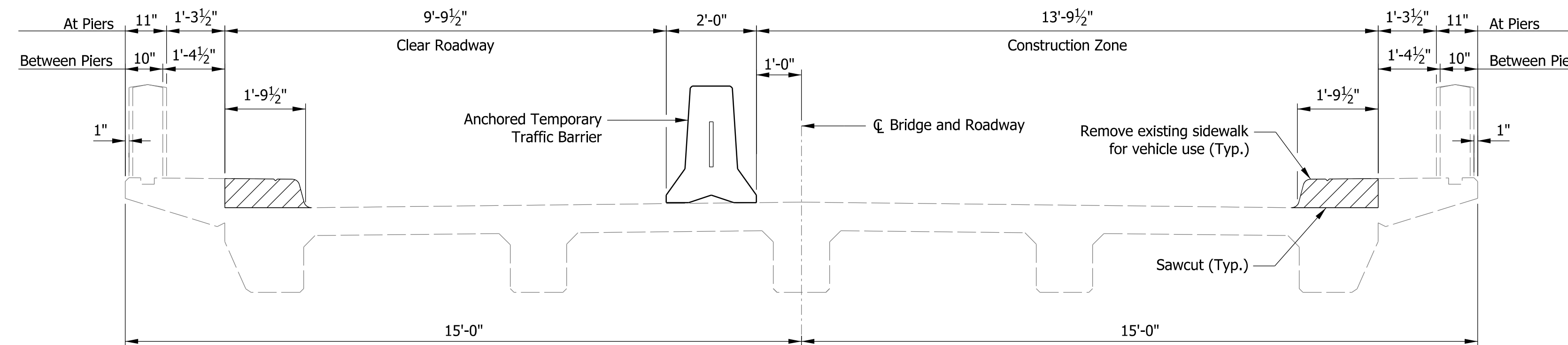

PHASE 2 SECTION
Scale: 1/2" = 1'-0"

DATE	REVISION

RECOMMENDED FOR APPROVAL	DESIGN ENGINEER	DATE
DESIGNED: RBR	6/13/2023	DRAWN: MGM
CHECKED: CMB	6/13/2023	CHECKED: CMB
		6/13/2023

INDIANA
DEPARTMENT OF TRANSPORTATION

**MAINTENANCE OF TRAFFIC
TYPICAL SECTIONS**

BRIDGE FILE	P000-64-07069
SCALE	DESIGNATION
1/2" = 1'-0"	2200175
SURVEY BOOK	SHEETS
CONTRACT	PROJECT
	2 of 2
	2200175

Alternative B: Detour Route US 12 to Tremont Rd.

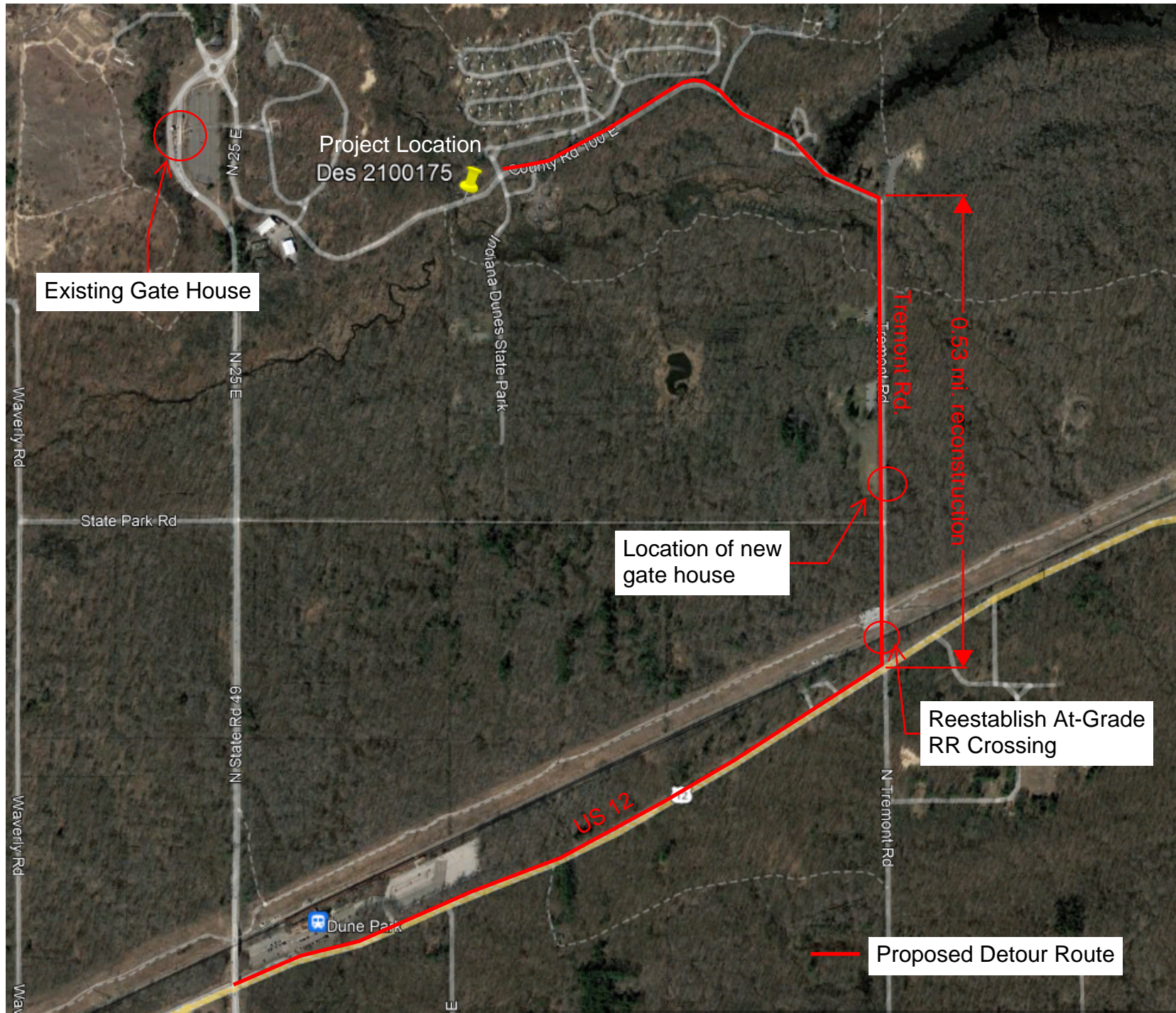

Alternative B: Detour Route State Park Rd. to Tremont Rd.



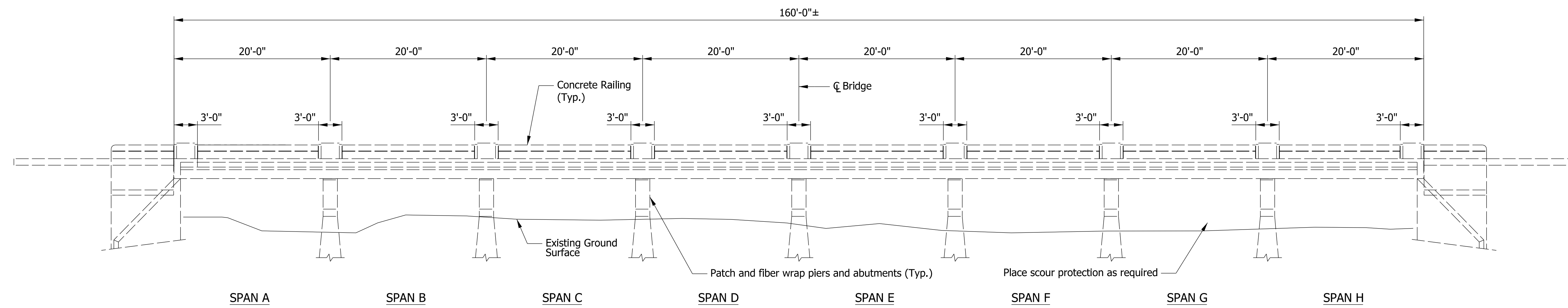

BRIDGE ELEVATION
Scale: 1/8"=1'-0"

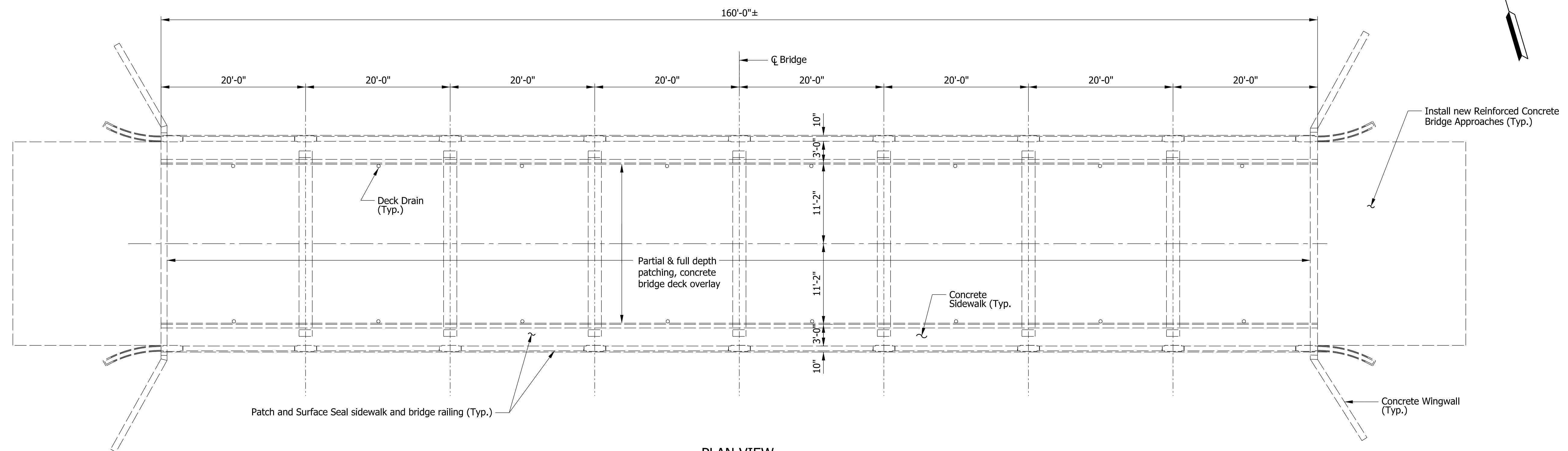

PLAN VIEW
Scale: 1/8"=1'-0"

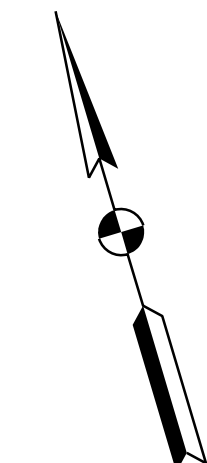

DATE	REVISION

RECOMMENDED FOR APPROVAL	DESIGN ENGINEER	6/29/2023	DATE
DESIGNED: RBR	6/13/2023	DRAWN: MGM	6/13/2023
CHECKED: CMB	6/13/2023	CHECKED: CMB	6/13/2023

INDIANA
DEPARTMENT OF TRANSPORTATION

**PLAN AND ELEVATION
ALTERNATIVE B1a**

BRIDGE FILE	P000-64-07069
SCALE	1/8" = 1'-0"
DESIGNATION	2200175
SURVEY BOOK	
CONTRACT	
SHEETS	1 of 2
PROJECT	2200175

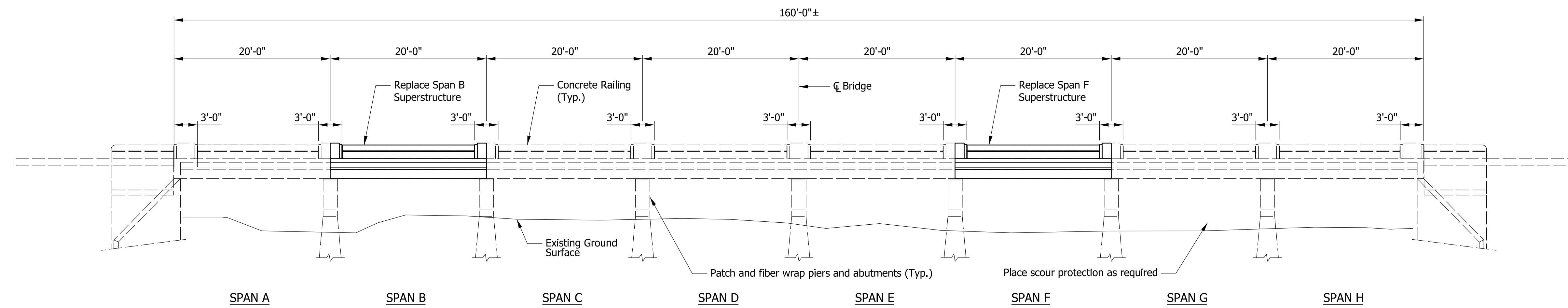

BRIDGE ELEVATION
Scale: 1/8" = 1'-0"

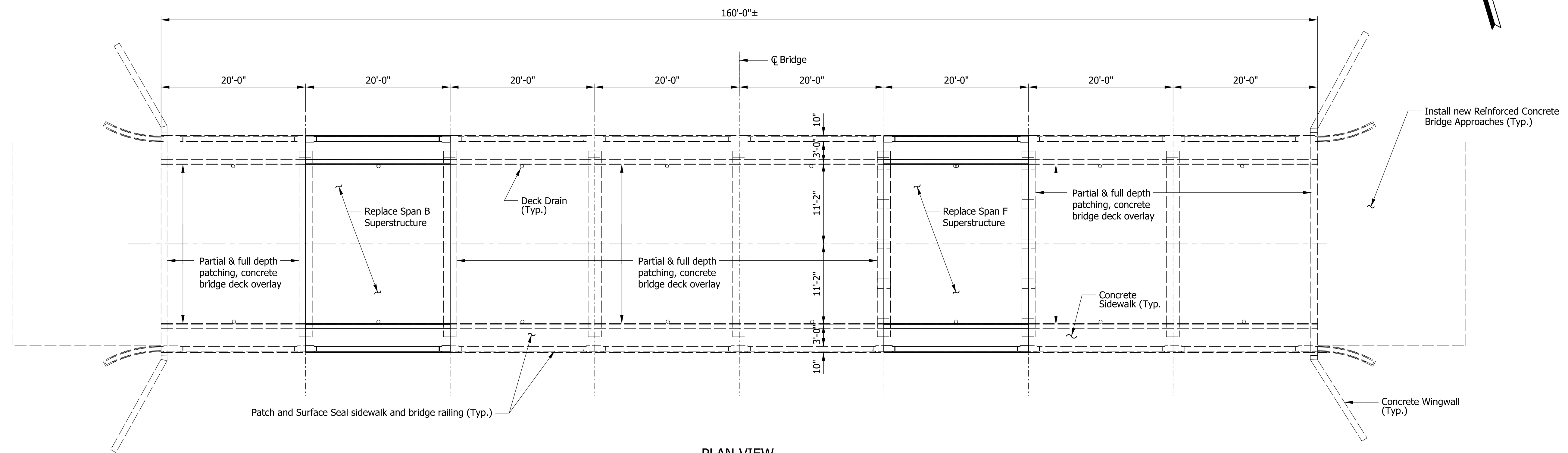

PLAN VIEW
Scale: 1/8" = 1'-0"

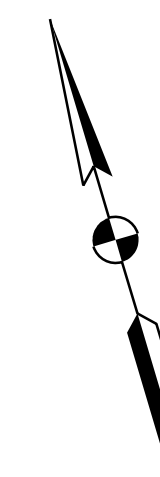

DATE	REVISION

RECOMMENDED FOR APPROVAL	DESIGN ENGINEER	6/29/2023	DATE
DESIGNED: RBR	6/13/2023	DRAWN: MGM	6/13/2023
CHECKED: CMB	6/13/2023	CHECKED: CMB	6/13/2023

INDIANA
DEPARTMENT OF TRANSPORTATION

PLAN AND ELEVATION
ALTERNATIVE B1b

BRIDGE FILE	P000-64-07069
SCALE	1/8" = 1'-0"
DESIGNATION	2200175
SURVEY BOOK	2 of 2
CONTRACT	PROJECT 2200175

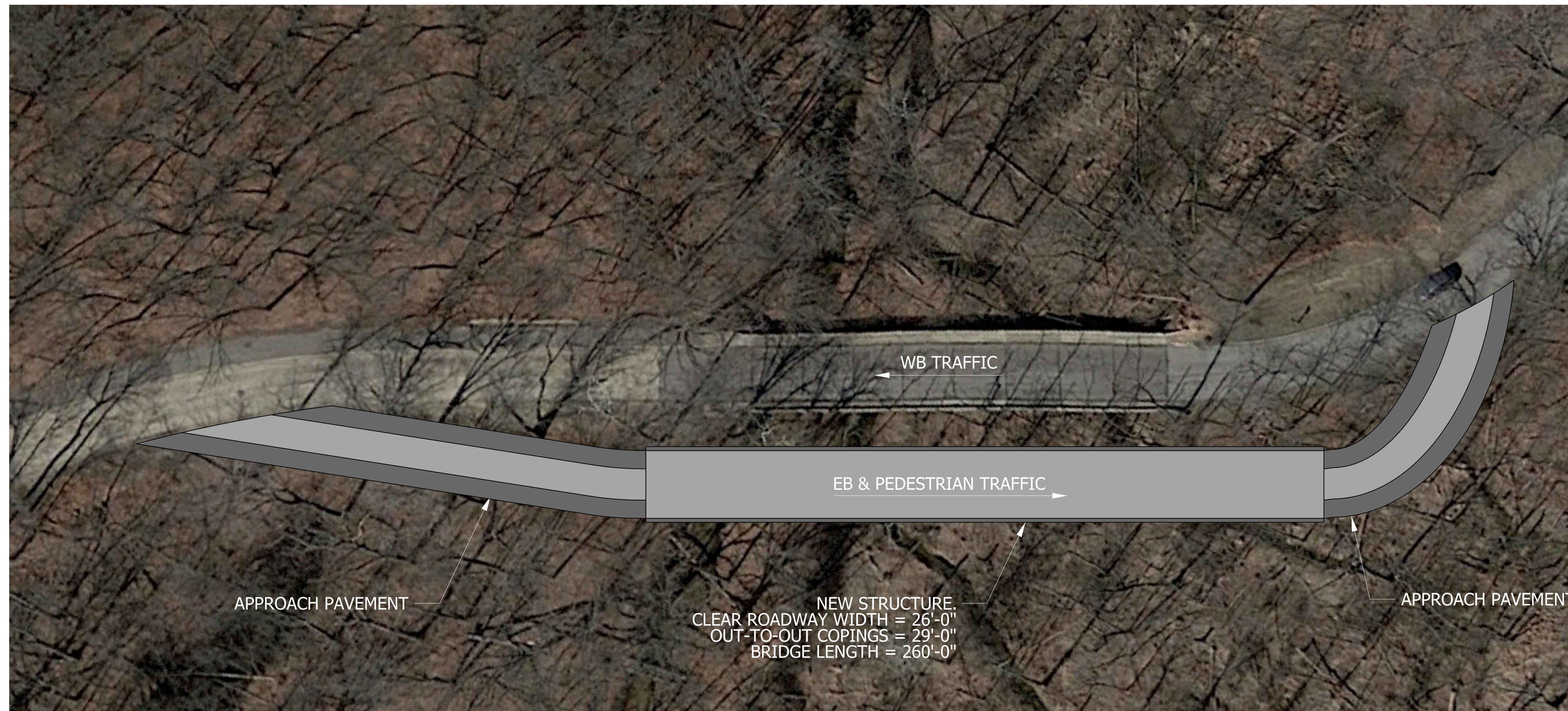
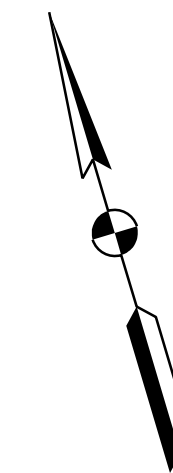

DATE	REVISION										BRIDGE FILE
											P000-64-07069
											DESIGNATION
											2200175
											SHEETS
											1 of 2
											PROJECT
											2200175

RECOMMENDED FOR APPROVAL		DESIGN ENGINEER	6/29/2023	DATE
DESIGNED: RBR	6/15/2023	DRAWN: MGM	6/15/2023	DATE
CHECKED: CMB	6/15/2023	CHECKED: CMB	6/15/2023	DATE

INDIANA	
DEPARTMENT OF TRANSPORTATION	
PROPOSED STRUCTURE LOCATION	

SCALE	1" = 20'
SURVEY BOOK	
CONTRACT	

Appendix E: Cost Estimates

PRICING REPORTDate: 09/01/2023
Time: 02:23:27Project: **Option B1a for HBAA**
Location: **Wilson Rd over Dunes Creek**
County: **PORTER**
District: **La Porte**Project ID: **2200175**
Bid Date: **11/13/2025** State: **IN**
Route: **Wilson Rd**

SortCd	Pay Item	Description	Quantity	Unit	Bid Price	Extension	Alt
1	105-06845	construction engineering	1.000	L.S.	84,000.00	84,000.00	
2	110-01001	mobilization and demobilization	1.000	L.S.	214,000.00	214,000.00	
3	201-52370	clearing right of way	1.000	L.S.	750,000.00	750,000.00	
4	202-02240	pavement removal	174.000	SYS	21.53	3,746.22	
5	203-02000	excavation, common	31,000.000	C.Y.	30.00	930,000.00	
6	203-02070	borrow	7,750.000	C.Y.	15.00	116,250.00	
7	205-12108	stormwater management budget	50,000.000	\$	1.00	50,000.00	
8	205-12616	stormwater management implementation	1.000	L.S.	50,000.00	50,000.00	
9	207-12635	subgrade treatment, type ibc	16,250.000	SYS	14.00	227,500.00	
10	214-12237	geotextile for pavement type 1b	21,000.000	SYS	3.00	63,000.00	
11	301-12234	compacted aggregate no. 53	7,000.000	C.Y.	80.00	560,000.00	
12	302-06464	subbase for pccp	30.000	C.Y.	106.73	3,201.90	
13	401-07321	qc/qa-hma, 2, 64, surface, 9.5 mm	1,625.000	TON	98.91	160,728.75	
14	401-07390	qc/qa-hma, 2, 64, intermediate, 19.0 mm	2,625.000	TON	96.18	252,472.50	
15	401-07407	qc/qa-hma, 2, 64, base, 25.0 mm	6,375.000	TON	99.41	633,738.75	
16	401-10258	joint adhesive, surface	6,600.000	L.F.	0.45	2,970.00	
17	401-10259	joint adhesive, intermediate	6,600.000	L.F.	0.63	4,158.00	
18	401-11785	liquid asphalt sealant	6,600.000	L.F.	0.24	1,584.00	
19	406-05520	asphalt for tack coat	14.000	TON	650.00	9,100.00	
20	609-06259	reinforced concrete bridge approach, 12 in.	102.000	S.Y.	176.39	17,991.78	
21	616-06405	riprap, revetment	1,500.000	TON	90.00	135,000.00	
22	616-12246	geotextile for riprap type 1a	500.000	SYS	4.81	2,405.00	
23	621-01004	mobilization and demobilization for seeding	1.000	EACH	576.48	576.48	
24	621-06553	seed mixture r	20.000	LBS	11.89	237.80	
25	703-06029	reinforcing bars, epoxy coated	5,653.000	LBS	1.82	10,288.46	
26	709-04647	fiber wrap concrete casing system	1.000	L.S.	300,000.00	300,000.00	
27	709-51821	surface seal	1.000	L.S.	25,000.00	25,000.00	
28	710-09158	patching concrete structures	3,803.000	S.F.	130.00	494,390.00	

PRICING REPORT

Date: 09/01/2023
Time: 02:23:27

Project: **Option B1a for HBAA**
Location: **Wilson Rd over Dunes Creek**
County: **PORTER**
District: **La Porte**

Project ID: **2200175**
Bid Date: **11/13/2025** State: **IN**
Route: **Wilson Rd**

SortCd	Pay Item	Description	Quantity	Unit	Bid Price	Extension	Alt
29	722-01061	bridge deck overlay, silica fume modified	398.000	S.Y.	100.00	39,800.00	
30	722-01066	hydrodemolition	398.000	SYS	77.60	30,884.80	
31	722-12380	bridge deck overlay, budget	6,128.000	\$	1.00	6,128.00	
32	722-12464	bridge deck, remove existing concrete surface	398.000	SYS	9.00	3,582.00	
33	722-12732	longitudinal grooving	398.000	SYS	7.59	3,020.82	
34	722-51401	bridge deck patching, full depth	72.000	S.F.	70.00	5,040.00	
35	722-51842	bridge deck overlay, latex modified	398.000	S.Y.	146.79	58,422.42	
36	722-51874	overlay dam	45.000	S.F.	67.12	3,020.40	
37	727-90308	epoxy injection, crack preparation	360.000	L.F.	64.42	23,191.20	
38	727-90309	epoxy injection, epoxy material	36.000	GAL	115.63	4,162.68	
39	727-93560	epoxy injection, furnishing equipment	1.000	L.S.	3,600.00	3,600.00	
40	801-06775	maintaining traffic	1.000	L.S.	156,000.00	156,000.00	

Subtotal	\$5,380,769.54
20% contingency	\$1,076,153.91
Total	\$6,456,923.45

Notes:

Option Bid items 722-06101 & 722-51842. Item 722-51842 extension not included in totals.

All Maintenance of Traffic items are accounted for in pay item 801-06775.

PRICING REPORTDate: 09/01/2023
Time: 02:25:04Project: **Option B1b for HBAA**
Location: **Wilson Rd over Dunes Creek**
County: **PORTER**
District: **La Porte**Project ID: **2200175**
Bid Date: **11/13/2025** State: **IN**
Route: **Wilson Rd**

SortCd	Pay Item	Description	Quantity	Unit	Bid Price	Extension	Alt
1	105-06845	construction engineering	1.000	L.S.	89,000.00	89,000.00	
2	110-01001	mobilization and demobilization	1.000	L.S.	226,000.00	226,000.00	
3	201-52370	clearing right of way	1.000	L.S.	750,000.00	750,000.00	
4	202-02240	pavement removal	174.000	SYS	21.53	3,746.22	
5	202-51328	present structure, remove portions	1.000	L.S.	150,000.00	150,000.00	
6	203-02000	excavation, common	31,000.000	C.Y.	30.00	930,000.00	
7	203-02070	borrow	7,750.000	C.Y.	15.00	116,250.00	
8	205-12108	stormwater management budget	50,000.000	\$	1.00	50,000.00	
9	205-12616	stormwater management implementation	1.000	L.S.	50,000.00	50,000.00	
10	207-12635	subgrade treatment, type ibc	16,250.000	SYS	14.00	227,500.00	
11	214-12237	geotextile for pavement type 1b	21,000.000	SYS	3.00	63,000.00	
12	301-12234	compacted aggregate no. 53	7,000.000	C.Y.	80.00	560,000.00	
13	302-06464	subbase for pccp	30.000	C.Y.	106.73	3,201.90	
14	401-07321	qc/qa-hma, 2, 64, surface, 9.5 mm	1,625.000	TON	98.91	160,728.75	
15	401-07390	qc/qa-hma, 2, 64, intermediate, 19.0 mm	2,625.000	TON	96.18	252,472.50	
16	401-07407	qc/qa-hma, 2, 64, base, 25.0 mm	6,375.000	TON	99.41	633,738.75	
17	401-10258	joint adhesive, surface	6,600.000	L.F.	0.45	2,970.00	
18	401-10259	joint adhesive, intermediate	6,600.000	L.F.	0.63	4,158.00	
19	401-11785	liquid asphalt sealant	6,600.000	L.F.	0.24	1,584.00	
20	406-05520	asphalt for tack coat	14.000	TON	1,100.80	15,411.20	
21	609-06259	reinforced concrete bridge approach, 12 in.	102.000	S.Y.	176.39	17,991.78	
22	616-06405	riprap, revetment	1,500.000	TON	90.00	135,000.00	
23	616-12246	geotextile for riprap type 1a	500.000	SYS	4.81	2,405.00	
24	621-01004	mobilization and demobilization for seeding	1.000	EACH	576.48	576.48	
25	621-06553	seed mixture r	20.000	LBS	11.89	237.80	
26	703-06029	reinforcing bars, epoxy coated	18,403.000	LBS	1.82	33,493.46	
27	704-51002	concrete, c, superstructure	51.000	C.Y.	1,600.00	81,600.00	
28	709-04647	fiber wrap concrete casing system	1.000	L.S.	300,000.00	300,000.00	

PRICING REPORT

Date: 09/01/2023
Time: 02:25:04

Project: **Option B1b for HBAA**
Location: **Wilson Rd over Dunes Creek**
County: **PORTER**
District: **La Porte**

Project ID: **2200175**
Bid Date: **11/13/2025** State: **IN**
Route: **Wilson Rd**

SortCd	Pay Item	Description	Quantity	Unit	Bid Price	Extension	Alt
29	709-51821	surface seal	1.000	L.S.	25,000.00	25,000.00	
30	710-09158	patching concrete structures	3,803.000	S.F.	130.00	494,390.00	
31	722-01061	bridge deck overlay, silica fume modified	398.000	S.Y.	100.00	39,800.00	
32	722-01066	hydrodemolition	298.000	SYS	77.60	23,124.80	
33	722-12380	bridge deck overlay, budget	6,452.000	\$	1.00	6,452.00	
34	722-12464	bridge deck, remove existing concrete surface	398.000	SYS	9.00	3,582.00	
35	722-12732	longitudinal grooving	398.000	SYS	7.59	3,020.82	
36	722-51401	bridge deck patching, full depth	54.000	S.F.	70.00	3,780.00	
37	722-51842	bridge deck overlay, latex modified	398.000	S.Y.	146.79	58,422.42	
38	722-51874	overlay dam	45.000	S.F.	67.12	3,020.40	
39	727-90308	epoxy injection, crack preparation	360.000	L.F.	64.42	23,191.20	
40	727-90309	epoxy injection, epoxy material	36.000	GAL	115.63	4,162.68	
41	727-93560	epoxy injection, furnishing equipment	1.000	L.S.	3,600.00	3,600.00	
42	801-06775	maintaining traffic	1.000	L.S.	156,000.00	156,000.00	

Subtotal	\$5,650,189.74
20% contingency	\$1,130,037.95
Total	\$6,780,227.69

Notes:

Option Bid items 722-06101 & 722-51842. Item 722-51842 extension not included in totals.

All Maintenance of Traffic items are accounted for in pay item 801-06775.

PRICING REPORT

Date: 09/08/2023
Time: 02:12:28

Project: **Option C for HBAA**
Location: **Wilson Rd over Dunes Creek**
County: **PORTER**
District: **La Porte**

Project ID: **2200175**
Bid Date: **11/13/2025** State: **IN**
Route: **Wilson Rd**

SortCd	Pay Item	Description	Quantity	Unit	Bid Price	Extension	Alt
1	105-06845	construction engineering	1.000	L.S.	84,000.00	84,000.00	
2	110-01001	mobilization and demobilization	1.000	L.S.	213,000.00	213,000.00	
3	201-52370	clearing right of way	1.000	L.S.	84,000.00	84,000.00	
4	202-02240	pavement removal	188.000	SYS	23.00	4,324.00	
5	202-51328	present structure, remove portions	1.000	L.S.	150,000.00	150,000.00	
6	203-02000	excavation, common	2,500.000	C.Y.	42.00	105,000.00	
7	203-02070	borrow	2,500.000	C.Y.	22.00	55,000.00	
8	205-12108	stormwater management budget	20,000.000	\$	1.00	20,000.00	
9	205-12616	stormwater management implementation	1.000	L.S.	20,000.00	20,000.00	
10	207-12635	subgrade treatment, type ibc	2,288.000	SYS	18.95	43,357.60	
11	211-06467	aggregate for end bent backfill	82.000	C.Y.	146.00	11,972.00	
12	214-12237	geotextile for pavement type 1b	2,500.000	SYS	4.50	11,250.00	
13	301-12234	compacted aggregate no. 53	1,000.000	C.Y.	95.00	95,000.00	
14	302-06464	subbase for pccp	64.000	C.Y.	115.95	7,420.80	
15	401-07321	qc/qa-hma, 2, 64, surface, 9.5 mm	195.000	TON	130.00	25,350.00	
16	401-07390	qc/qa-hma, 2, 64, intermediate, 19.0 mm	315.000	TON	115.90	36,508.50	
17	401-07407	qc/qa-hma, 2, 64, base, 25.0 mm	765.000	TON	120.00	91,800.00	
18	401-10258	joint adhesive, surface	800.000	L.F.	0.64	512.00	
19	401-10259	joint adhesive, intermediate	800.000	L.F.	0.78	624.00	
20	401-11785	liquid asphalt sealant	800.000	L.F.	0.28	224.00	
21	406-05520	asphalt for tack coat	2.000	TON	1,250.00	2,500.00	
22	601-12281	guardrail mgs w-beam, 6 ft 3 in spacing	400.000	L.F.	35.00	14,000.00	
23	601-94689	guardrail, end treatment, os	8.000	EACH	4,750.00	38,000.00	
24	602-06729	barrier, delineator	8.000	EACH	24.75	198.00	
25	609-06259	reinforced concrete bridge approach, 12 in.	230.000	S.Y.	200.00	46,000.00	
26	616-06405	riprap, revetment	3,000.000	TON	107.95	323,850.00	
27	616-12246	geotextile for riprap type 1a	500.000	SYS	5.85	2,925.00	
28	621-01004	mobilization and demobilization for seeding	1.000	EACH	625.56	625.56	

PRICING REPORT

Date: 09/08/2023
Time: 02:12:28

Project: **Option C for HBAA**
Location: **Wilson Rd over Dunes Creek**
County: **PORTER**
District: **La Porte**

Project ID: **2200175**
Bid Date: **11/13/2025** State: **IN**
Route: **Wilson Rd**

SortCd	Pay Item	Description	Quantity	Unit	Bid Price	Extension	Alt
29	621-06553	seed mixture r	10.000	LBS	12.25	122.50	
30	701-09558	test pile, indicator, production	480.000	L.F.	120.00	57,600.00	
31	701-09560	test pile, indicator, restrrike	8.000	EACH	3,500.00	28,000.00	
32	701-09739	pile shoe, hp 12 x 53	40.000	EACH	220.00	8,800.00	
33	701-51195	pile, steel h hp 12 x 53	2,400.000	L.F.	132.00	316,800.00	
34	702-51005	concrete, a, substructure	242.000	C.Y.	1,600.00	387,200.00	
35	703-06029	reinforcing bars, epoxy coated	170,278.000	LBS	1.99	338,853.22	
36	704-51002	concrete, c, superstructure	565.000	C.Y.	1,387.00	783,655.00	
37	706-09960	railing, concrete fc	520.000	L.F.	175.00	91,000.00	
38	706-11620	concrete bridge railing transition, tfc	4.000	EACH	3,300.00	13,200.00	
39	709-04647	fiber wrap concrete casing system	1.000	L.S.	300,000.00	300,000.00	
40	709-51821	surface seal	1.000	L.S.	25,000.00	25,000.00	
41	710-09158	patching concrete structures	3,803.000	S.F.	140.00	532,420.00	
42	722-01061	bridge deck overlay, silica fume modified	398.000	S.Y.	105.62	42,036.76	
43	722-01066	hydrodemolition	298.000	SYS	90.32	26,915.36	
44	722-12380	bridge deck overlay, budget	6,452.000	\$	1.00	6,452.00	
45	722-12464	bridge deck, remove existing concrete surface	398.000	SYS	14.57	5,798.86	
46	722-12732	longitudinal grooving	398.000	SYS	9.52	3,788.96	
47	722-51401	bridge deck patching, full depth	54.000	S.F.	75.00	4,050.00	
48	722-51842	bridge deck overlay, latex modified	398.000	S.Y.	146.79	58,422.42	
49	722-51874	overlay dam	45.000	S.F.	82.00	3,690.00	
50	727-90308	epoxy injection, crack preparation	360.000	L.F.	69.50	25,020.00	
51	727-90309	epoxy injection, epoxy material	36.000	GAL	122.39	4,406.04	
52	727-93560	epoxy injection, furnishing equipment	1.000	L.S.	3,600.00	3,600.00	
53	801-06775	maintaining traffic	1.000	L.S.	147,000.00	147,000.00	

Subtotal	\$4,642,850.16
20% contingency	\$928,570.83
Total	\$5,571,420.19

Notes:

Option Bid items 722-06101 & 722-51842. Item 722-51842 extension not included in totals.

All Maintenance of Traffic items are accounted for in pay item 801-06775.

Appendix F:
Bridge Existing Conditions and Applicable
Design Criteria Table

Alternative B1a					
Design Element	Design Manual Section	Minimum Design Criteria	Existing Condition	Proposed Condition	Design Exception Required
Design Speed	412-5.03	Existing Posted Speed	20 MPH	20 MPH	No
Bridge Clear Roadway Width	Fig. 412-2B	20 ft	22'-4"	22'-4"	No
Structural Capacity	Fig. 412-2A	HS-20	HS-20	HS-20	No
Horizontal Curve, minimum radius	Fig. 53-5	80 ft	> 80 ft	> 80 ft	No
Travel Lane Cross Slope	Fig. 53-5	2%	2%	2%	No
Bridge Railing	412-5.03	Existing if no crash history in past 5 years	Unknown	Match existing (no crash history within last 5 years)	Yes
ADA Compliance	PROWAG	Sidewalk Width: 5'-0"	Sidewalk Width: 2'-11"	Sidewalk Width: 2'-11"	Yes

Alternative B1b					
Design Element	Design Manual Section	Minimum Design Criteria	Existing Condition	Proposed Condition	Design Exception Required
Design Speed	412-5.03	Existing Posted Speed	20 MPH	20 MPH	No
Bridge Clear Roadway Width	Fig. 412-2B	20 ft	22'-4"	22'-4"	No
Structural Capacity	Fig. 412-2A	HS-20	HS-20	HS-20	No
Horizontal Curve, minimum radius	Fig. 53-5	80 ft	> 80 ft	> 80 ft	No
Travel Lane Cross Slope	Fig. 53-5	2%	2%	2%	No
Bridge Railing	412-5.03	Existing if no crash history in past 5 years	Unknown	Match existing (no crash history within last 5 years)	Yes
ADA Compliance	PROWAG	Sidewalk Width: 5'-0"	Sidewalk Width: 2'-11"	Sidewalk Width: 2'-11"	Yes

Alternative C

Design Element	Design Manual Section	Minimum Design Criteria	Existing Condition	Proposed Condition	Design Exception Required
Design Speed	Historic Bridge: 412-5.03 New Bridge: Fig 53-5	Historic Bridge: Existing Posted Speed New Bridge: 30 MPH	Historic Bridge: 20 MPH	Historic Bridge: 20 MPH New Bridge: 30 MPH	No
Bridge Clear Roadway Width	Historic Bridge: Fig. 412-2B New Bridge: Fig. 53-5	Historic Bridge: 20 ft New Bridge: Travelway + 4 ft =16 ft	Historic Bridge: 22'-4"	Historic Bridge: 22'-4" New Bridge: 26'-0"	No
Structural Capacity	Historic Bridge: Fig. 412-2A New Bridge: Fig. 53-5	Historic Bridge: HS-20 New Bridge: HL-93	Historic Bridge: HS-20	Historic Bridge: HS-20 New Bridge: HS-20	No
Horizontal Curve, minimum radius	Fig. 53-5	80 ft	Historic Bridge: > 80 ft	Historic Bridge: > 80 ft New Bridge: > 80 ft	No
Travel Lane Cross Slope	Fig. 53-5	Historic Bridge: 2% New Bridge: 2%	Historic Bridge: 2%	Historic Bridge: 2% New Bridge: 2%	No
Bridge Railing	Historic Bridge: 412-5.03 New Bridge: 404-4.02	Historic Bridge: Existing if no crash history in past 5 years New Bridge: TL-2	Unknown	Historic Bridge: Match existing (no crash history within last 5 years) New Bridge: TL-3	Yes
ADA Compliance	PROWAG	Historic Bridge: Does not comply with minimum sidewalk width (5'-0")	Historic Bridge: Does not comply	Historic Bridge: Eliminate pedestrian traffic, ADA becomes N/A New Bridge: Complies	No

Appendix G: Field Check Meeting Minutes

DATE/TIME: Thursday, April 27, 2023 / 11:00 AM EST / 10:00 AM CST

FILE CODE: Hanson Project 21H0001C

LOCATION: Project Site; Indiana Dunes State Park

SUBJECT: Initial Bridge Field Check for the Contract and Des No:

RFP#	Des. No.	Contract & Description
O210112d	2200175	B-44263 – Wilson Rd over Dunes Creek Historic Bridge Rehab.

PURPOSE:

To perform an inspection of the condition and required repairs for the bridge. This inspection and discussion between Hanson, INDOT, and IDNR will be used in the development of the Historic Bridge Alternatives Analysis.

ATTENDEES:

Name	Organization	Phone	Email
Jomary Baller	DNR Engineering	317-234-8731	jballer@dnr.IN.gov
Matthew Pore	DNR Engineering	317-234-0176	mpore@dnr.IN.gov
David Nance	DNR Engineering	317-234-1111	dnance@dnr.IN.gov
Doug Lang	DNR	812-270-2954	dlang1@dnr.IN.gov
Michael Rea	DNR	219-214-2016	Mrea1@dnr.IN.gov
John Krueckeberg	INDOT	260-348-1303	jkruckeberg@indot.IN.gov
Haley Brinker	INDOT		hbrinker@indot.IN.gov
Mary Kennedy	INDOT	317-694-3607	mkennedy@indot.IN.gov
Chris Vergon	INDOT	219-325-7487	cvergon@indot.IN.gov
Karen Wood	SJCA	317-847-9856	kwood@sjcainc.com
Chad Kelly	Kaskaskia Engineering	630-333-7282	ckelly@kaskaskiaeng.com
Jessica Stern	Kaskaskia Engineering	217-213-3046	jstern@kaskaskiaeng.com
Jason Rowley	Hanson Professional Services	317-605-7860	jrowley@hanson-inc.com
Mike DiFranco	Hanson Professional Services	463-900-1501	mdifranco@hanson-inc.com

Name	Organization	Phone	Email
Rober Rust	Hanson Professional Services	317-808-3982	rrust@hanson-inc.com
Wyatt Huber	Hanson Professional Services	463-274-5325	whuber@hanson-inc.com
Chris Beres	Hanson Professional Services	463-230-0723	cberes@hanson-inc.com

DISCUSSION: Information discussed at the meeting is added in *blue italics*.

A. Schedule: The anticipated schedule submitted in Hanson’s scope and fee proposal:

- Begin Section 106 Review – 6/1/23
- Historic Bridge Alternatives Analysis (HBAA) Report – 7/1/2023
- HBAA Approval – 8/15/2023
- Stage 2 (30%) – 10/15/2023
- Final Field Check – 9/15/2024
- Final Environmental Document Approval – 2/21/2025
- Target Permits Approval - 3/7/2025
- Stage 3 (95%) – 3/21/2025
- Final Tracings – 7/21/2025
- Ready for Contracts – 8/20/2025
- Letting – 11/13/2025

- *John Krueckeberg advised that there is potential for Stage 3 submittal to be made for preliminary review prior to the NEPA document being approved to keep the project schedule on track.*
- *There is potential for an expedited review of permits by DNR.*

B. Environmental Document and Permits Discussion

- Categorical Exclusion Level 4 is anticipated.
- Early Coordination Letters
 - To be sent upon INDOT approval of Draft Purpose and Need statement.
- Red Flag Investigation (RFI)
 - *6-month review time for RFI is anticipated.*
- Waters Determination Report
 - *6-month review time for Waters Report is anticipated.*
- U.S. Fish and Wildlife Service (USFWS) Information for Planning and Consultation (IPaC) submittal
- Section 4f Review
- Public *Hearing*
 - *Historic bridge status requires a public hearing to be held.*
 - *Necessary response time shall be considered when scheduling the public hearing.*
- Permit Determination Checklist submittal.
 - Section 401/404 and Construction in a Floodway (CIF) permits anticipated.

- *DNR representatives stated that they could request an expedited review on the project team's behalf to assist with the CIF process.*

C. Section 106 and Archaeology

- Section 106
 - *Anticipate Section 106 approval in 2024.*
- Archaeological Phase Ia Reconnaissance Survey and Report
- Consulting parties
 - Discuss required parties to be listed.
 - *Include attendees of this meeting.*
 - *Include Ben Clark, DNR Chief of Natural Resources*

D. Utility Coordination

- All utilities are owned by the Park.
- Sewer line attached to the bridge.
- Water and communications are in the area, need to be located.
 - *The fiber line was installed approximately 4 years ago and is attached to the north coping of the bridge in gray conduit above the sewer pipe.*
- As built utility drawings
 - *The Park will follow up on maps of existing utility facilities within the park.*

E. Road, Structure, Drainage, and MOT Design:

- **Acceptable Rehabilitation Alternatives** – To be explored in HBAA Report
 - No build / Do nothing
 - Rehabilitation for continued vehicular use
 - Rehabilitation for continued vehicular use (1 way pair option)
 - New bypass structure, rehab existing bridge for non-vehicular use
 - Relocation of existing bridge, new bridge in its place
- **Approaches**
 - Short section of full depth HMA with transition milling and overlay to tie in to existing roadway.
 - Pavement sections to be selected per Indiana Design Manual Figure 601-5C, Pavement Design for Standalone Bridge and Small Structure Projects.
 - *Existing pavement on east approach is HMA.*
 - *Existing pavement on west approach is concrete.*
 - Approach Slab Options
 - Patch and overlay approach slabs as needed.
 - Replace in kind.
 - *Two existing curb ramps on west side of bridge, crossing Wilson Rd. Multi-use path connects to west end of bridge on north side. Unpaved trail (Trail #2) connects Wilson Rd just west of bridge on south side.*
 - *Short section of vertical curb along east approach (north side, approx. 70-80 feet). No other curbing or storm infrastructure identified along approaches.*

- *Wooden fence located on north side of west approach with signage to deter hikers from deviating from trail.*
- *Short section of retaining wall along north side of west approach (approx. 100 feet from bridge on sideslope of embankment.)*
- **Bridge Deck**
 - Existing plans indicate 2, 11'-2" lanes.
 - Patch and surface seal sidewalks and railings
 - Remove existing asphalt overlay.
 - Patch existing deck
 - Extend existing deck drains.
 - Place rigid overlay
 - Original plans show 7.5" deck with 1.5" top reinforcement cover.
- **Superstructure**
 - 5 cast in place beams spaced at 5'-10".
 - 8 Spans, lettered A through H from west to east
 - Patching required on beams and diaphragms.
 - Clean and replace expansion joints with pre-compressed foam joints.
 - Potential need for replacement of spans B and F
- **Substructure**
 - Existing piers have 5 columns on spread footings.
 - Existing footing geometry is unknown.
 - Existing substructure units to remain in place.
 - Patching is required on piers, abutments and wingwalls.
- **Drainage**
 - Scour analysis is being completed by INDOT Hydraulics
 - *INDOT PM to follow up with status of scour analysis by INDOT Hydraulics.*
 - Approach roadway drainage
 - *DNR Park Operations confirmed no issues with approach drainage were known. No additional drainage structures needed.*
- **Maintenance of Traffic**
 - Per kickoff meeting discussion on 2/10/23:
 - State Park Rd. south of the project is partially owned by the Indiana Dunes National Park and not available for use as a detour.
 - Tremont Rd. east of the project no longer connects to State Park Rd. or the W Dunes Highway.
 - *Further discussion regarding the possibility of utilizing these roadways as detour routes was held but was determined not to be feasible in current state. Significant reconstruction of the roadways would be required (roadways are substandard width, and nearly impassible in current state). Additionally, the route would require*

reestablishing at-grade crossing with multiple rail lines, and would not be feasible within tight project timeline.

- Potential options
 - *DNR and Park Operations reiterated that full closure of any significant duration (greater than 1 week) would not be feasible. Park campground and other amenities remain open year-round and are a crucial revenue source not only for the Dunes State Park, but also funds many other State Park facilities.*
 - *DNR stated that it is possible to close the pedestrian facility on the bridge during construction if needed, as there is not significant pedestrian use.*
 - Phased construction with flagging or temporary signals
 - Required lane width.
 - *Consensus of participants present was that the existing bridge width would be insufficient to maintain traffic during phased construction once positive protection measures (i.e. temporary traffic barrier) were in place.*
 - Temporary structure to bypass existing bridge.
 - General consensus of participants was that a temporary bypass structure would be the most feasible alternative.
 - Hanson to further evaluate, but preliminary location on south side of existing structure appears to have least impacts to surrounding embankment, trees, and wetland features.

F. Additional Discussion

- *INDOT PM will need updated cost estimates for possible alternatives being evaluated to discuss with Kathy Eaton-McKalip for additional funding. Project is already underfunded, so Change Management will be necessary to incorporate additional funding. Hanson intends to provide these cost estimates in the HBAA Report.*