



# INDIANA DEPARTMENT OF TRANSPORTATION

*Driving Indiana's Economic Growth*

## Design Memorandum No. 11-13 Technical Advisory

August 17, 2011

**TO:** All Design, Operations, and District Personnel, and Consultants

**FROM:** /s/ Anthony L. Uremovich  
Anthony L. Uremovich  
Manager, Office of Bridge Standards and Policy  
Bridge Design, Inspection, Hydraulics, and Technical Support Division

**SUBJECT:** Structural Steel Cleaning and Painting

**REVISES:** *Indiana Design Manual Sections 17-5.11, 17-5.11(04), and 17-5.11(05)*

**EFFECTIVE:** September 8, 2011, Letting

Steel-bridge painting and partial-bridge painting are no longer designated by type. The color of the final coat should be shown in revised Summarization 17-5K, Bridge-Painting Locations and Information, attached herewith. The revised version of the summarization also appears on the INDOT editable-documents webpage,

<http://www.in.gov/dot/div/contracts/design/dmforms/index.html>.

Standard paint colors are provided in the INDOT *Standard Specifications*. After consultation with the project manager, one of these colors should be specified for the final coat, and the color number from the Standard Specifications placed in the summarization's appropriate blank. Light blue or light green is typically specified. Colors not listed in the *Standard Specifications* should be specified only after consultation with the project manager. Reasons for using non-standard colors include a request from an LPA, desire to match surroundings, etc. A non-standard color requires a longer lead time for the contractor to procure the paint and for the paint to be tested.

Bridge cleaning and partial-bridge cleaning are designated by QP type. The QP designation refers to the contractor's certification level.

If the structure was built in 1995 or later, the QP-1 designation should be used. If all or a portion of the structure to be cleaned was built in 1994 or earlier, the QP-2 designation should be used. The Department's *Bridge Inventory Log Book*'s year built should be used to determine the QP type.

If possible, the number of bridge sites in one painting contract should be limited to not more than three.

A new Standard Drawing, 619-PRWS-01, has been developed which shows caulking and painting limits for weathering steel. It is attached herewith.

The pay unit is lump sum. If portions of the steel are to be painted, they should be identified on the plans.

alu  
Attachment



[P:\Structural Services\Design Memos\Signed\2011\1113-ta.doc]

ARCHIVED

**NOTE:**

1. Caulk shall be placed on the painted surface at the painted/unpainted interface and is intended to function as a drip bead.

**LEGEND:**

-  = Area to be painted
-  = Caulk Bead

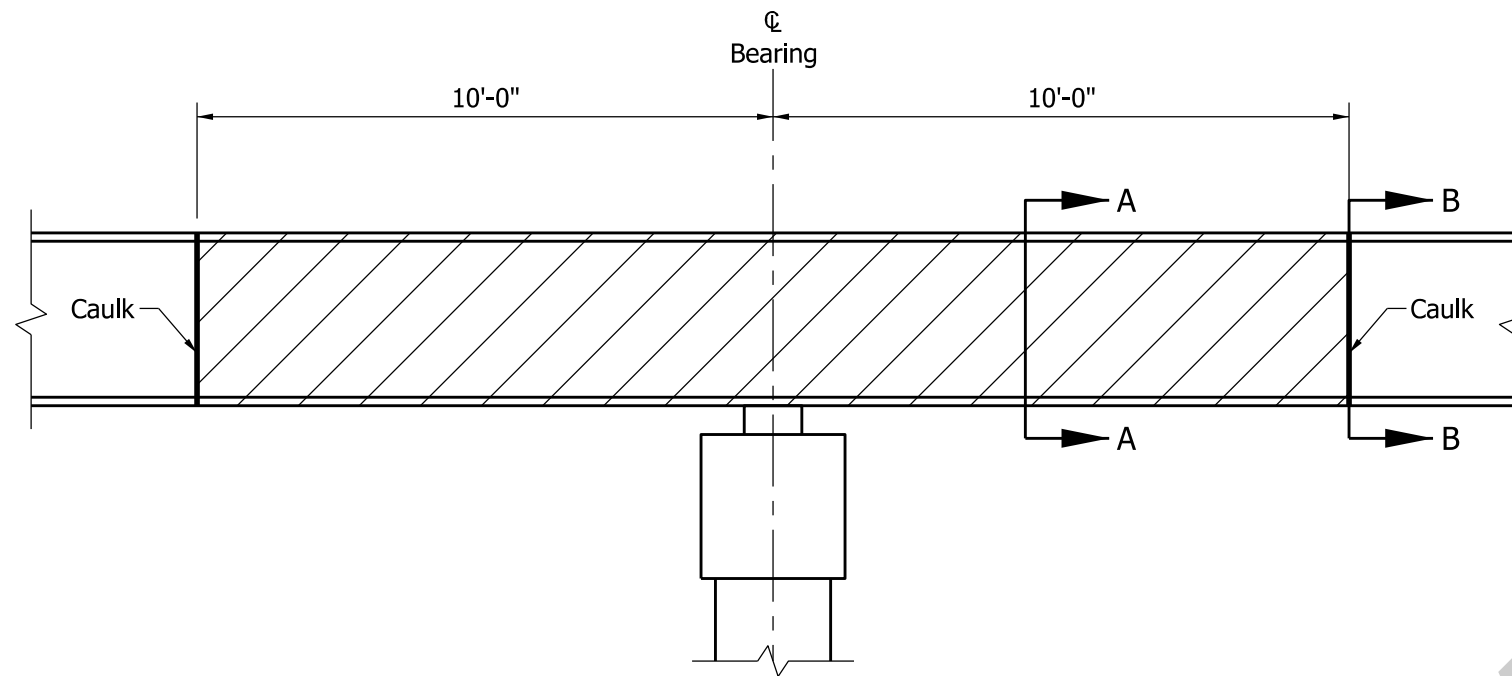

**BEAM OR GIRDER AT INTERIOR SUPPORT**

ELEVATION VIEW  
(Bridge Deck not shown for clarity)

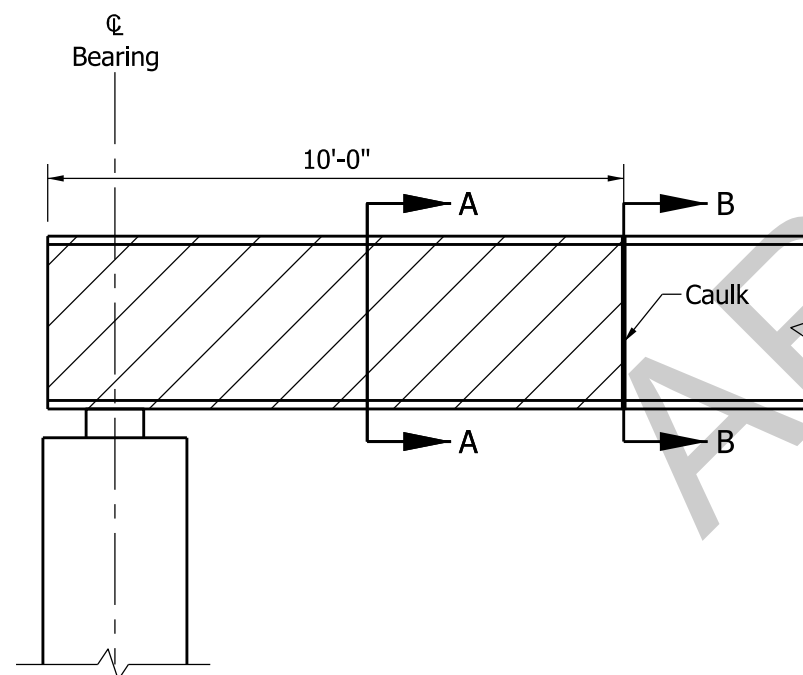

**BEAM OR GIRDER AT END-BENT SUPPORT**

ELEVATION VIEW  
(Bridge Deck, Mudwall, and Concrete Encasement not shown for clarity)

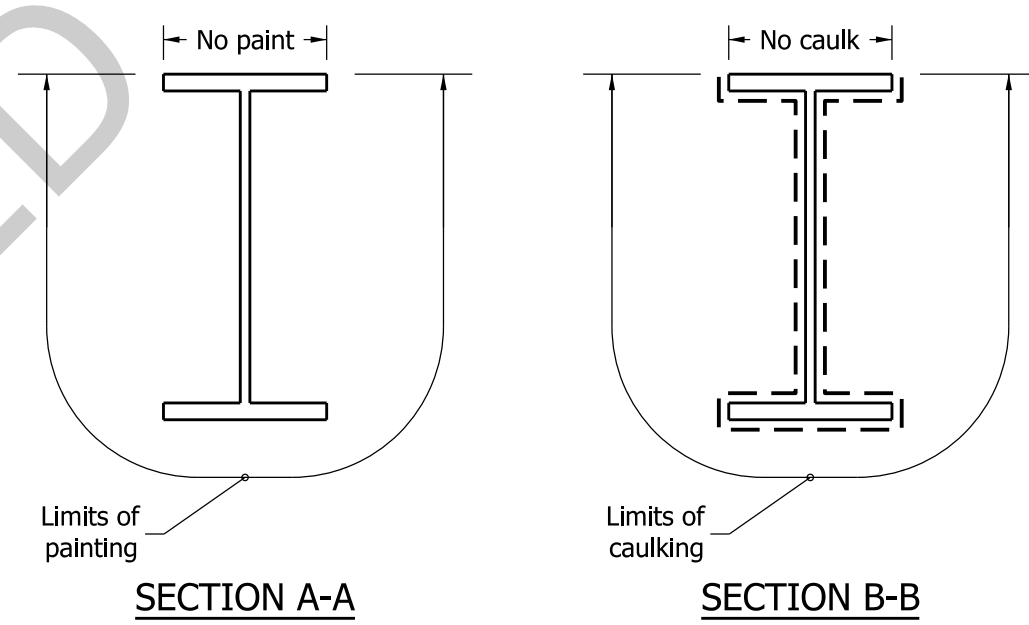

Limits of painting

**SECTION A-A**

Limits of caulking

**SECTION B-B**

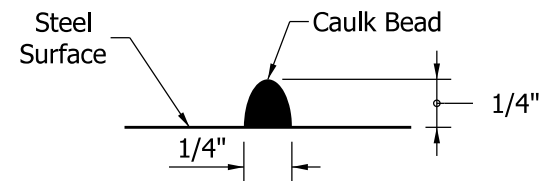

**CAULK BEAD DETAIL**

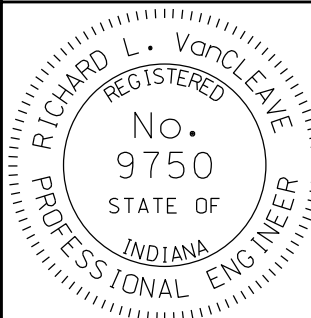
INDIANA DEPARTMENT OF TRANSPORTATION	
PAINTING REQUIREMENTS FOR WEATHERING STEEL	
SEPTEMBER 2011	
STANDARD DRAWING NO.	E 619-PRWS-01
	<i>/s/ Richard L. VanCleave</i> 09/01/11
	DESIGN STANDARDS ENGINEER      DATE
	<i>/s/ Mark A. Miller</i> 09/01/11
	CHIEF HIGHWAY ENGINEER      DATE
DESIGN STANDARDS ENGINEER	