



INDIANA DEPARTMENT OF TRANSPORTATION

Driving Indiana's Economic Growth

Design Memorandum No. 10-21 Technical Advisory

September 2, 2010

TO: All Design, Operations, and District Personnel, and Consultants

FROM: /s/ Richard L. VanCleave
Richard L. VanCleave
Roadway Standards Engineer
Highway Design and Technical Support Division

SUBJECT: Lane-Shift and Merging Tapers

REVISES: *Indiana Design Manual* Figures 46-4M and 76-2B

DELETES: *Indiana Design Manual* Figure 45-4A

EFFECTIVE: Immediately

The subject *Indiana Design Manual* figures have been revised for consistency and clarity. They are attached herewith. They have also been changed out on the appropriate *Manual* webpages.

Subject Figure 45-4A, which duplicates most of the information shown in Figure 76-2B, along with its references, has been deleted from the appropriate *Manual* webpage.

rlv:alu
Attachments

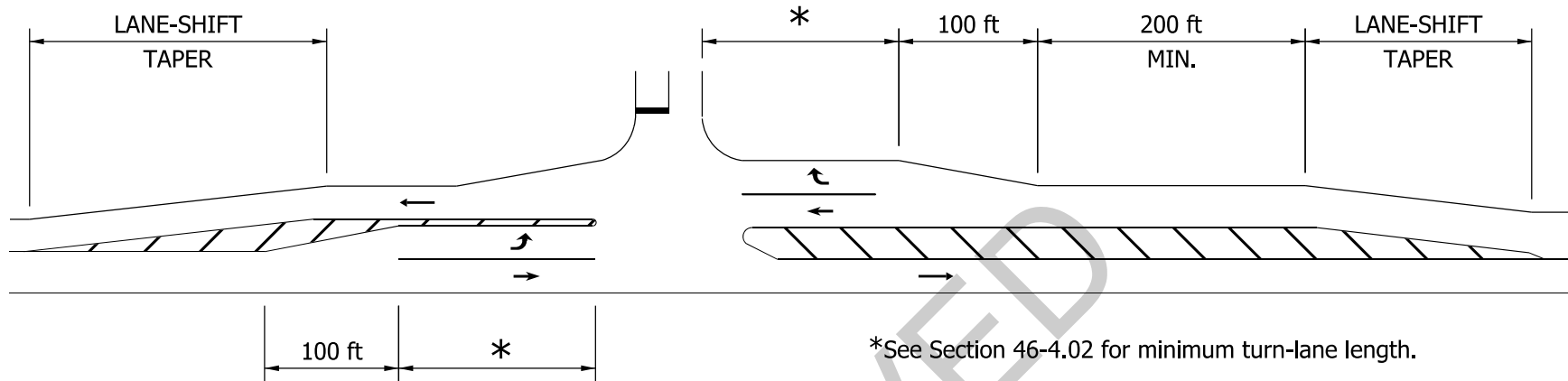

Design Speed (mph)	Lane-Shift Taper Rate
20	5:1
25	5:1
30	8:1
35	10:1
40	18:1
45	23:1
50	25:1
55	28:1
60	30:1
65	33:1
70	35:1

CHANNELIZED TURN LANE FOR 2-LANE HIGHWAY

Figure 46-4M

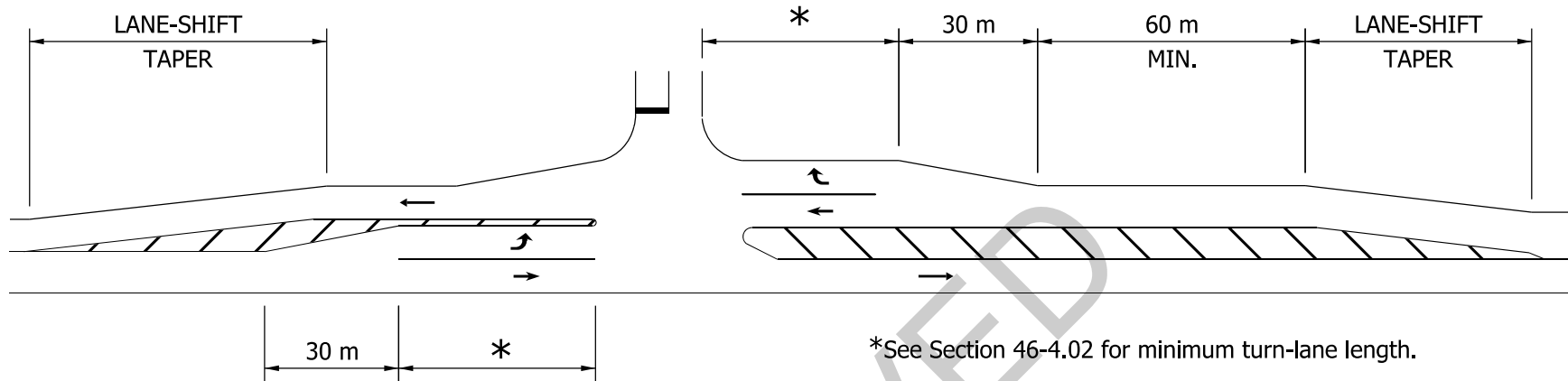

Design Speed (km/h)	Lane-Shift Taper Rate
30	5:1
40	5:1
50	8:1
60	10:1
70	23:1
80	25:1
90	28:1
100	30:1
110	35:1

CHANNELIZED TURN LANE FOR 2-LANE HIGHWAY

Figure 46-4M

Design Speed (mph)	Merging- Taper Rate
20	10:1
25	10:1
30	15:1
35	20:1
40	30:1
45	45:1
50	50:1
55	55:1
60	60:1
65	65:1
70	70:1

Taper Type		Minimum Taper Length
Upstream	Merging Taper (Lane Drop)	L
	Lane-Shift Taper	$\frac{1}{2} L$
	Shoulder Taper	$\frac{1}{3} L$
	Two-Way-Traffic Taper	100 ft
Downstream		50 ft / lane ²

Notes:

1. *Taper Length, L = Merging-Taper Rate x Offset Distance*
2. *The desirable length is 100 ft / lane.*
3. *Figure 76-2C illustrates the various types of tapers.*

LONGITUDINAL TAPER RATE AND LENGTH

Figure 76-2B

Design Speed (km/h)	Merging- Taper Rate
30	10:1
40	10:1
50	15:1
60	20:1
70	45:1
80	50:1
90	55:1
100	60:1
110	70:1

Taper Type		Minimum Taper Length
Upstream	Merging Taper (Lane Drop)	L
	Lane-Shift Taper	$\frac{1}{2} L$
	Shoulder Taper	$\frac{1}{3} L$
	Two-Way Traffic Taper	30 m
Downstream		15 m / lane ²

Notes:

1. Taper Length, $L = \text{Merging-Taper Rate} \times \text{Offset Distance}$
- ² The desirable length is 30 m / lane.
3. Figure 76-2C illustrates the various types of tapers.

LONGITUDINAL TAPER RATE AND LENGTH

Figure 76-2B