

NOTES:

- See Standard Drawing E 706-TTBC-01 for bridge railing transition type TBC. See Standard Drawing E 706-TTBT-01 for bridge railing transition type TBT. See Standard Drawing E 601-TTGB-01 for Guardrail transition type TGB.
- ② These holes, required for the connection of the guardrail transition type TBC or TBT to the end of the concrete bridge railing transition, shall be preformed.

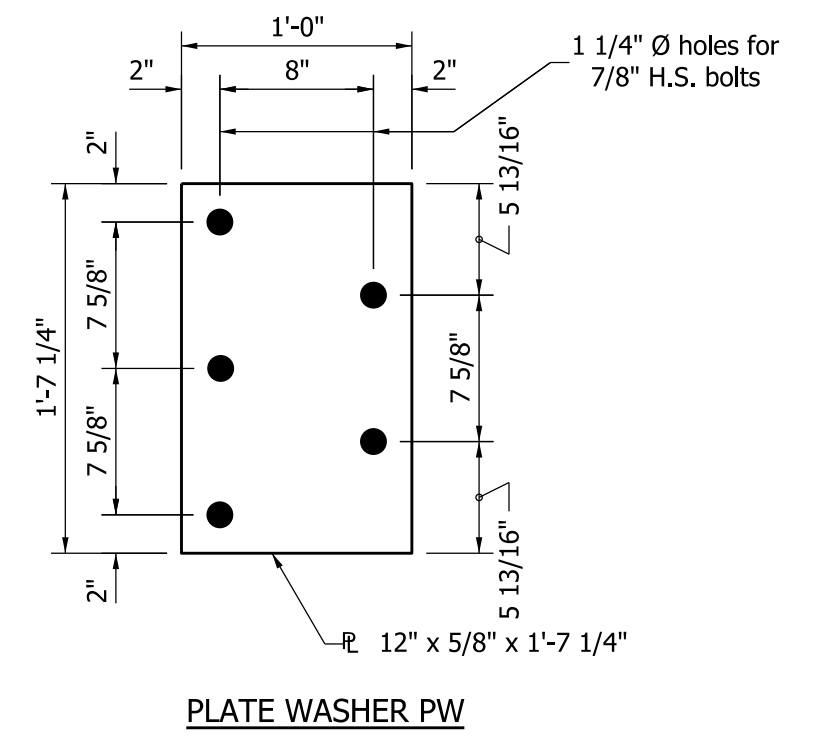

INDIANA DEPARTMENT OF TRANSPORTATION		
BRIDGE RAILING TRANSITION TBC OR TBT ATTACHMENT OF GUARDRAIL		
SEPTEMBER 2011		
STANDARD DRAWING NO.	E 706-CBRT-04	
	/s/ <i>Richard L. VanCleave</i>	09/01/11
	DESIGN STANDARDS ENGINEER	DATE
DESIGN STANDARDS ENGINEER	/s/ <i>Mark A. Miller</i>	09/01/11
	CHIEF HIGHWAY ENGINEER	DATE