

NOTES:

1. The sealing ribs shown in Alternate section C-C and D-D are optional for pads Type 3 and 4. If used, the rib shall extend along all sides of the pad, both top and bottom.

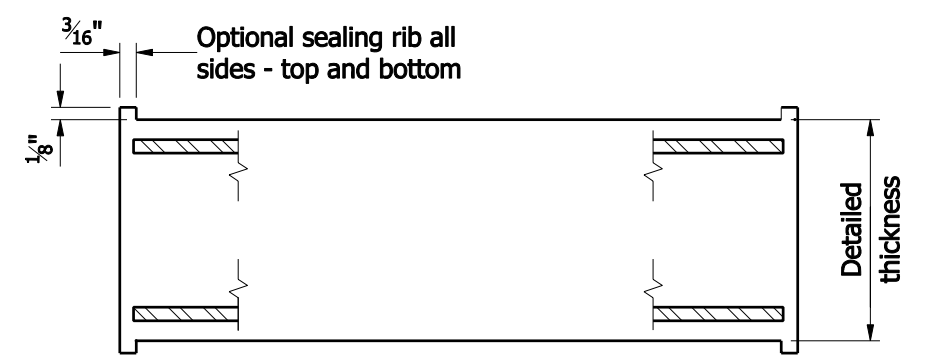

OPTIONAL SEALING RIBS
ALTERNATE SECTIONS A-A AND B-B

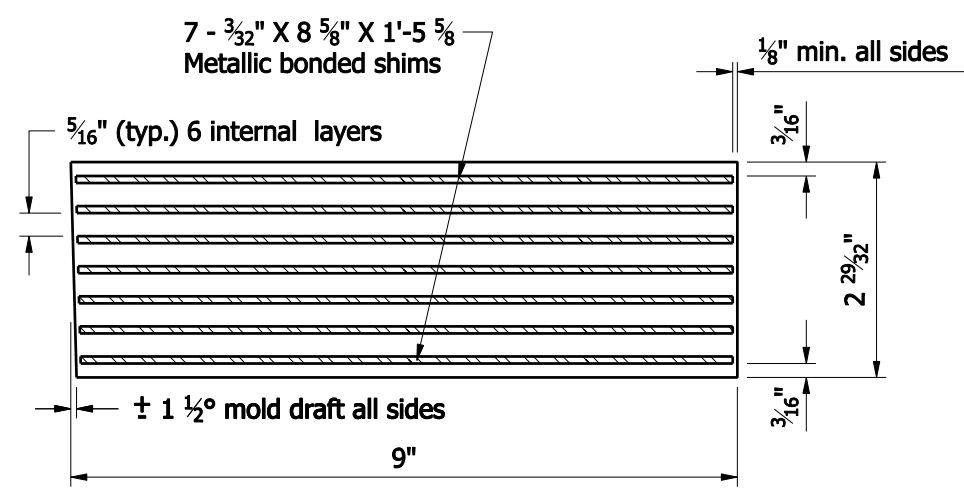

SECTION C-C
TYPE 3

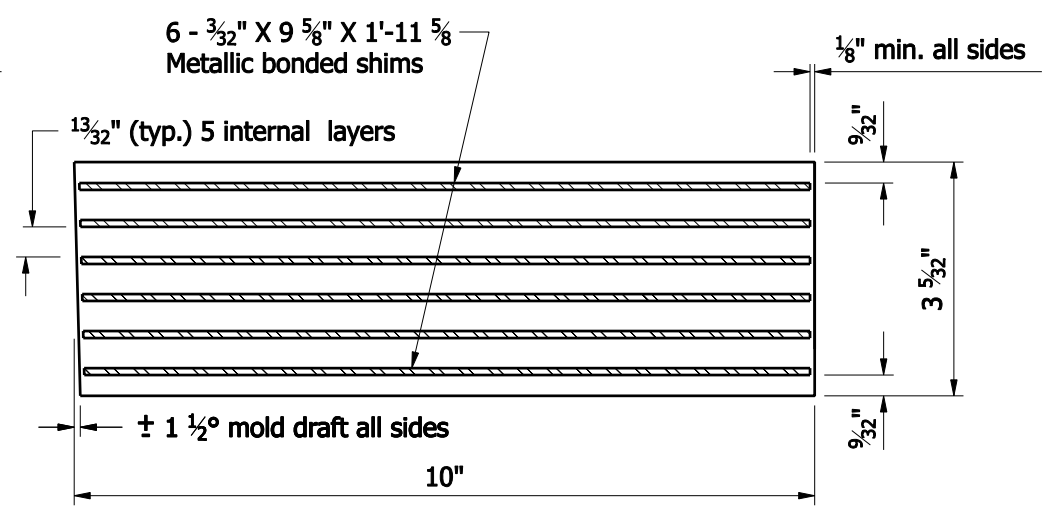

SECTION D-D
TYPE 4

INDIANA DEPARTMENT OF TRANSPORTATION	
ELASTOMERIC BEARING PADS TYPE 3 & 4	
SEPTEMBER 2008	
STANDARD DRAWING NO. E 707- BEBP-02	
	<i>/s/ Richard L. VanCleave</i> 09/02/08 DESIGN STANDARDS ENGINEER DATE
	<i>/s/ Mark A. Miller</i> 09/02/08 CHIEF HIGHWAY ENGINEER DATE
DESIGN STANDARDS ENGINEER	