

REINFORCEMENT DETAILS

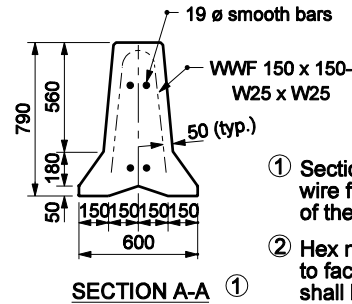

NOTES :

- ① Section A-A shows reinforcement with welded wire fabric. The WWF may be bent to the shape of the wall.
- ② Hex nut may be tack welded to bottom spacer to facilitate installation and removal. Bolts shall be torqued only to tight condition. Clearance between the spacer and the ends of the barrier shall permit angular deflection at the joints to permit flare rate 11 : 1 or flatter.
- ③ Top spacer TS 100 x 50 x 8 x 250 long
- ④ Bottom spacer TS 100 x 50 x 8 x 400 long
- 5 Where necessary to meet short radius curving alignment, the shorter top spacer (250) may be substituted for the standard bottom spacer (400).
- 6 For additional connection details see Standard Drawing 801-TCCB-01.
- ⑦ Where very short radius curving alignment is encountered, spacers may be TS 76 x 51 x 6.4 x the appropriate length as shown above.
- ⑧ This is an English gauge designation. There is no metric gauge equivalent in the welded wire fabric industry.
- ⑨ In lieu of the connection detail shown, the J-J Hook temporary barrier connection of Easi-Set Industries as described in FHWA acceptance letter B-52 of March 26, 1999 may be used.

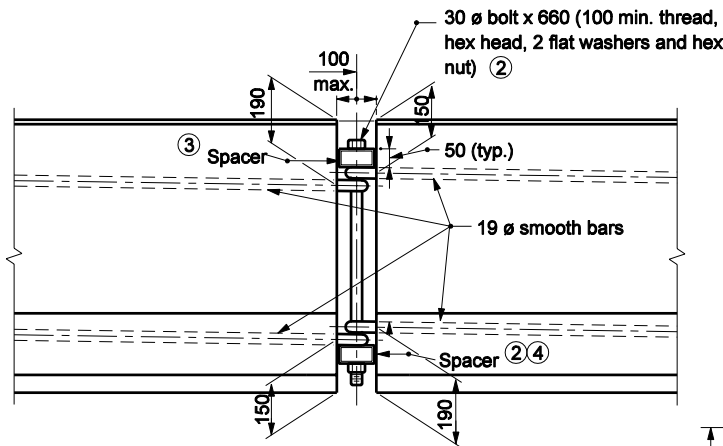

FRONT VIEW  
CONNECTION DETAIL

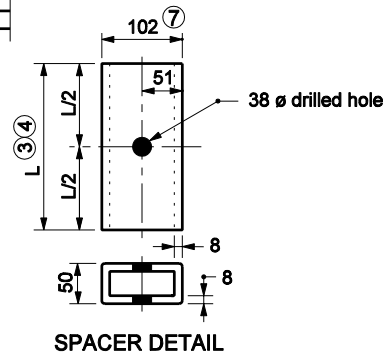

SPACER DETAIL

All Dimension are in mm unless otherwise specified

INDIANA DEPARTMENT OF TRANSPORTATION	
<b>TEMPORARY CONCRETE BARRIER DETAILS</b>	
MARCH 2005	
STANDARD DRAWING NO. 801-TCCB-02	
	<i>/s/ Richard L. VanCleave</i> 3-01-05 <small>DESIGN STANDARDS ENGINEER DATE</small>
	<i>/s/ Richard K. Smutzer</i> 3-01-05 <small>CHIEF HIGHWAY ENGINEER DATE</small>
<small>DESIGN STANDARDS ENGINEER</small>	