

KEEPER PLATE

PROCEDURE FOR ASSEMBLY OF BASE CONNECTION:

Assemble post to stub with bolts. One flat washer on each bolt shall be placed between the top of the keeper plate and bottom of the top base plate. Shim as required to plumb post.

Tighten all bolts the maximum possible with 12" to 25" wrench to bed washers and shims and to clean bolt threads, then loosen each bolt in turn and retighten bolts in a systematic order to the prescribed torque. See table on Standard Drawing E 802-SNGP-05 for dimensions.

Burr threads at junction with nuts using a center punch to prevent nut loosening.

Stubs shall be plumb and base plate shall be leveled and physically held level until the concrete sets.

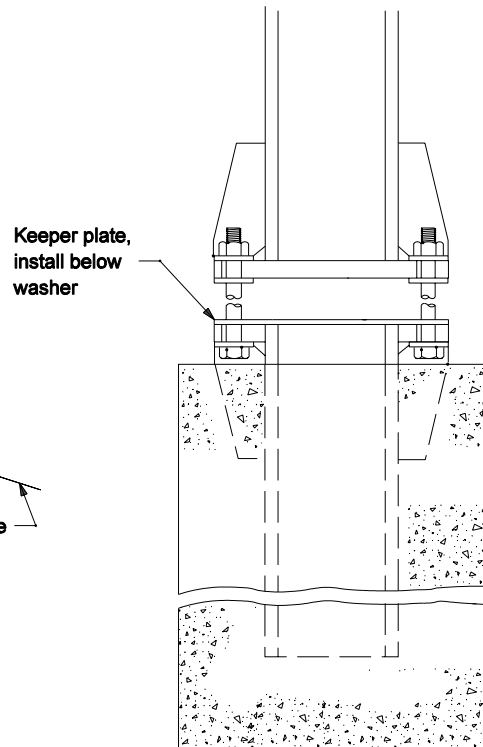
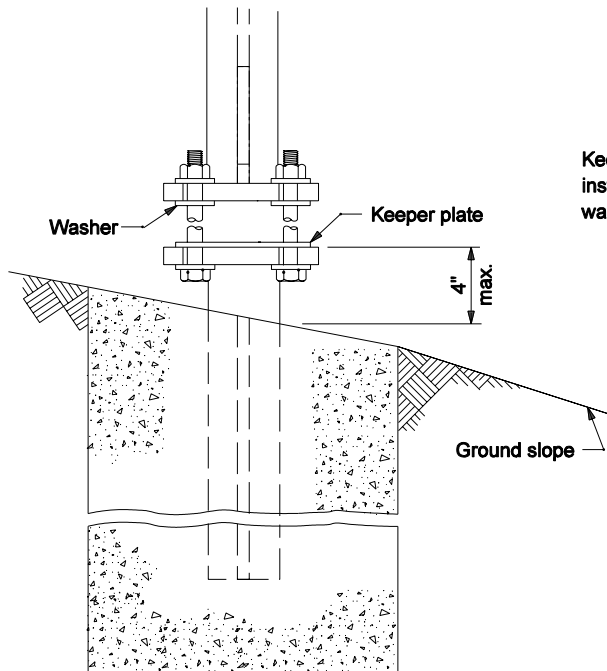

INDIANA DEPARTMENT OF TRANSPORTATION	
WIDE FLANGE SIGN SUPPORT BASE	
March 2004	
STANDARD DRAWING NO. E 802-SNGP-02	
	/s/ Richard L. VanCleave 3-01-04 DESIGN STANDARDS ENGINEER DATE
	/s/ Richard K. Smutzer 3-01-04 CHIEF HIGHWAY ENGINEER DATE
DESIGN STANDARDS ENGINEER	