

**CONSTANT PLATE SIZE ACROSS JOINT**

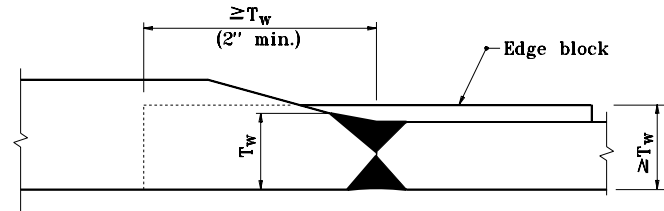

**THICKNESS TRANSITION**

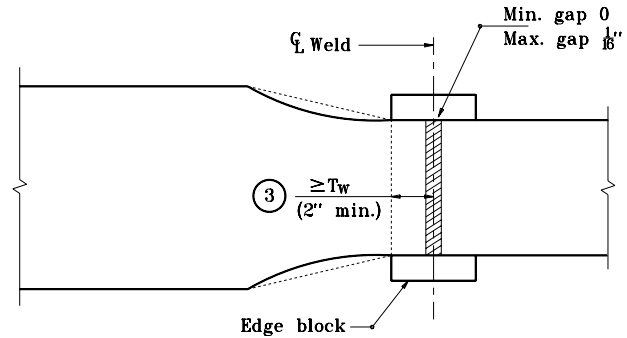

**WIDTH TRANSITION**

**NOTES :**

1. This drawing shows the fabrication methods used in structural steel plates not having rolled edges.
2. Edge blocks shall be used when radiographing flange butt shop welds of greater than  $\frac{1}{2}$ " thickness. Edge block shall not be tack welded.
- ③ The transition may start beyond the edge block.
4.  $T_w$  = Maximum weld thickness at joint.

INDIANA DEPARTMENT OF TRANSPORTATION	
<b>STEEL STRUCTURES</b>	
PLACEMENT OF RADIOGRAPHIC EDGE BLOCKS	
MAY 2000	
STANDARD DRAWING NO. <b>E 711-BREB-01</b>	
	/s/ Anthony L. Uremovich 5-01-00 DESIGN STANDARDS ENGINEER DATE
	/s/ Firooz Zandi 5-01-00 CHIEF HIGHWAY ENGINEER DATE