

**GENERAL NOTES**

- ① Toe plate extension is to be the same thickness as the end section. Dimension shall be end section overall width less 150.
- ② Transverse safety bars shall be Schedule 40 galvanized steel pipe. Pipe to be galvanized after forming. Number of bars req'd will vary depending on the length of the end section.
- ③ See Standard Drawing 715-SMES-11 for Section A-A.
- 4. See Standard Drawing 715-SMES-12 for variable dimensions.

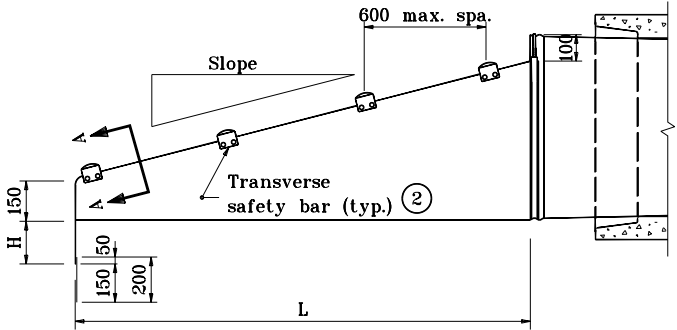

**SIDE ELEVATION OF PARALLEL STRUCTURE END SECTION**

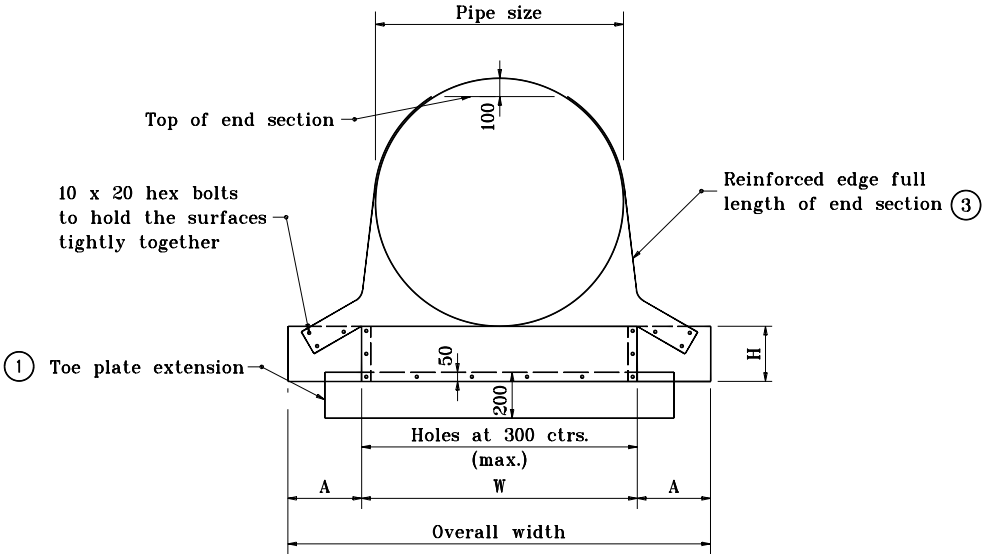

**FRONT VIEW**

All dimensions are in mm unless otherwise specified.

INDIANA DEPARTMENT OF TRANSPORTATION  
**SAFETY METAL CULVERT END SECTIONS FOR SMOOTH PIPE**  
 JANUARY 1998

STANDARD DRAWING NO. **715-SMES-10**

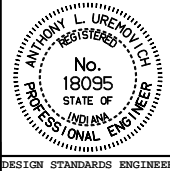

/s/ Anthony L. Uremovich 1-02-98  
 DESIGN STANDARDS ENGINEER DATE

/s/ Donald W. Lucas 1-02-98  
 CHIEF HIGHWAY ENGINEER DATE

Source Sheet: **SMES4**