

PLAN VIEW

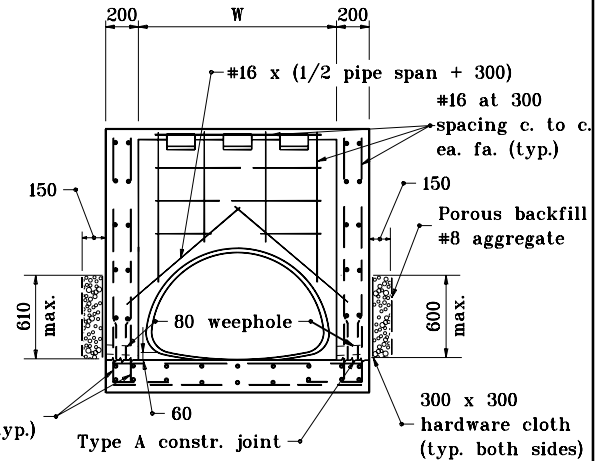

**GRATE REMOVED
SECTION B-B**

GENERAL NOTES

1. The invert grade of the grated box end section shall be the same as that of the pipe.
2. See Standard Drawing 715-GBTO-04 for Details A, B, C, and D.
3. See Standard Drawings 715-GBTO-05 through -08 for tables.
4. Type I grated box end sections shall be used for mainline cross-culverts' outlet pipes within the clear zone.
5. See Standard Drawing 715-GBTO-02 for bending diagrams.

All dimensions are in mm unless otherwise specified.

INDIANA DEPARTMENT OF TRANSPORTATION

**GRATED BOX END SECTION
TYPE I**
JANUARY 1999

STANDARD DRAWING NO. 715-GBTO-03

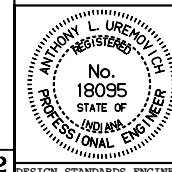

/s/ Anthony L. Uremovich 1-04-99
DESIGN STANDARDS ENGINEER DATE

/s/ Donald W. Lucas 1-04-99
CHIEF HIGHWAY ENGINEER DATE

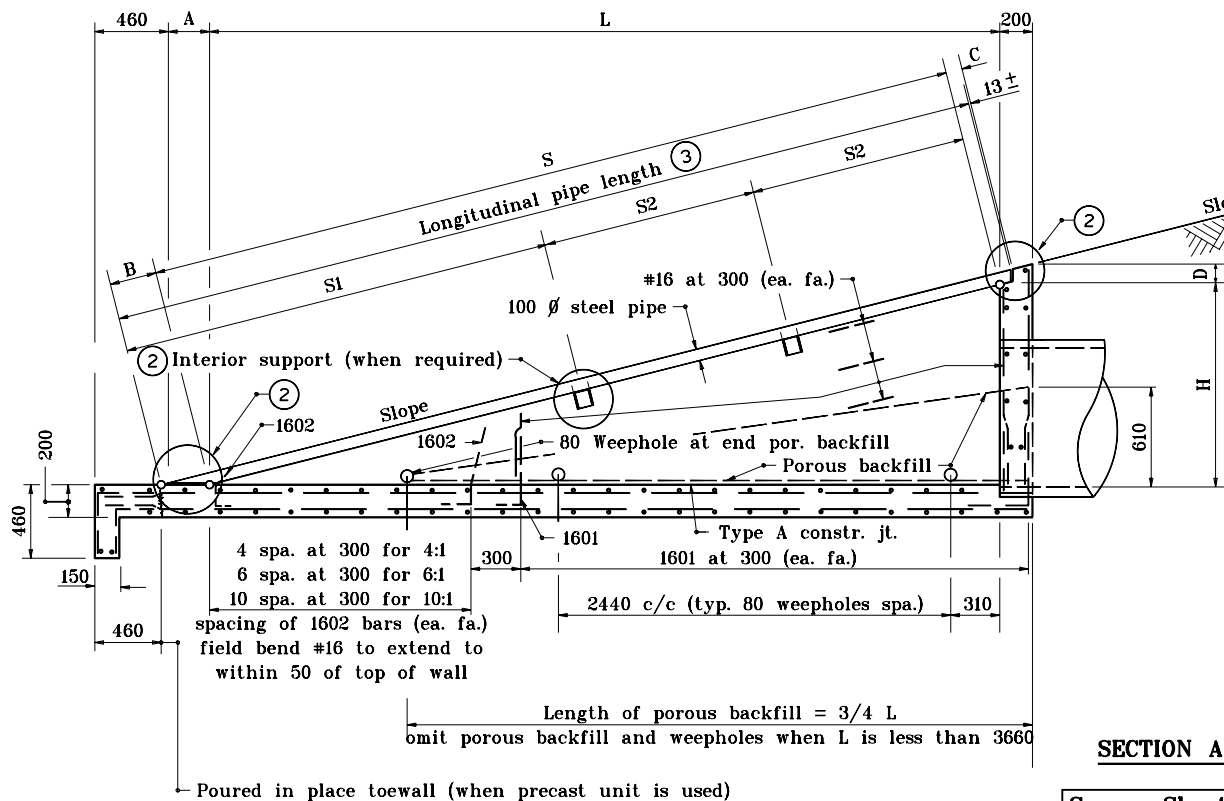

SECTION A-A