

**SERVICE POINT
TYPE I**

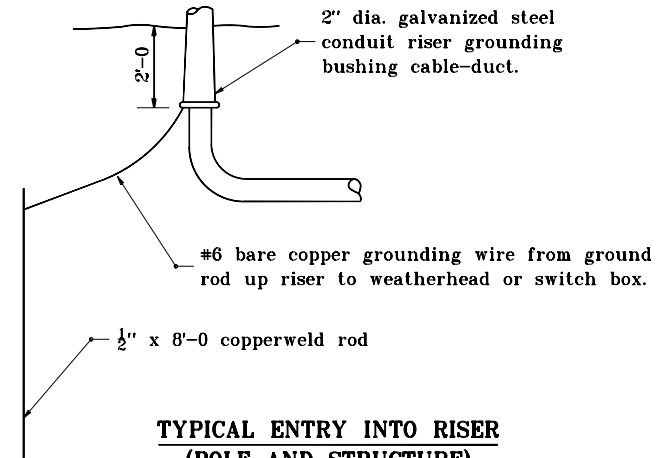

**TYPICAL ENTRY INTO RISER
(POLE AND STRUCTURE)**

DETAIL B

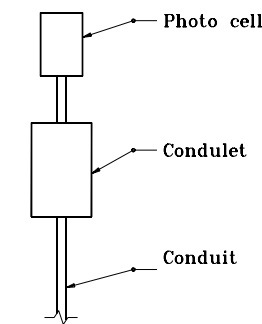

DETAIL C

INDIANA DEPARTMENT OF TRANSPORTATION	
LIGHT SERVICE POINT DETAILS	
SEPTEMBER 1998	
STANDARD DRAWING NO. E 807-LTSP-01	
DETAILS PLACED IN THIS FORMAT 11-15-99	
	/s/ Anthony L. Uremovich 11-15-99 DESIGN STANDARDS ENGINEER DATE
	/s/ Firooz Zandi 11-15-99 CHIEF HIGHWAY ENGINEER DATE
DESIGN STANDARDS ENGINEER	ORIGINALLY APPROVED 9-01-98