

SECTION A-A

BARRIER ANCHORAGE ON ASPHALT PAVEMENT

- NOTES:**
1. Anchorage against lateral movement is required for temporary concrete barrier located on concrete or asphalt pavement or shoulder where it is on or within 60 ft. of a bridge or where it is used on flared alignments. The method of anchoring shall be as shown.
 2. For connection details see Standard Drawing E 801-TCCB-02.
 3. Where barrier is on soil the 1" anchor bolts shall be 3'-0 long.

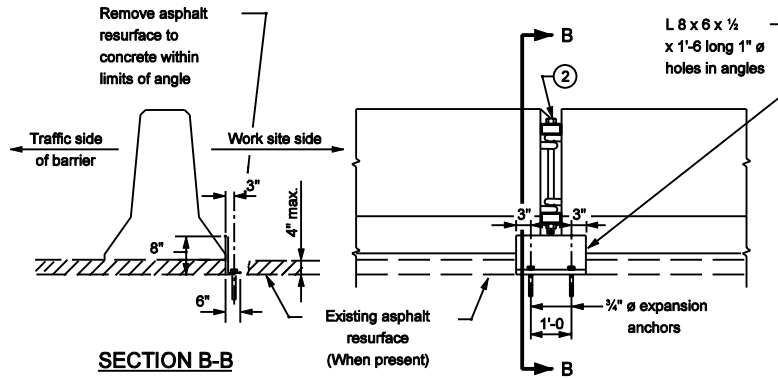

SECTION B-B

**BRIDGE FLOORS AND CONCRETE PAVEMENT
STANDARD METHOD**

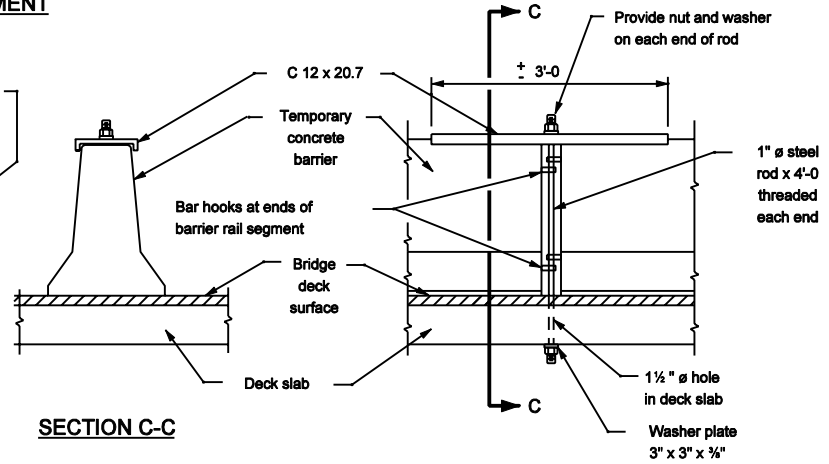

SECTION C-C

**BRIDGE FLOOR ONLY
ALTERNATE METHOD**

BARRIER ANCHORAGE ON CONCRETE PAVEMENT

INDIANA DEPARTMENT OF TRANSPORTATION

**TEMPORARY CONCRETE BARRIER
ANCHORAGE**

SEPTEMBER 2002

STANDARD DRAWING NO. E 801-TCCB-04

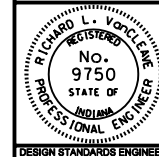

/s/ Richard L. VanCleave 9-03-02
DESIGN STANDARDS ENGINEER DATE

/s/ Richard K. Smutzer 9-03-02
CHIEF HIGHWAY ENGINEER DATE

DESIGN STANDARDS ENGINEER