

**GENERAL NOTES**

- ① If inlet pipe is required, A<sub>1</sub> and B<sub>1</sub> shall be increased or decreased 1'-0" as directed.
- ② 2" dia. pipe drain from bottom of curb to inlet. Aggregate to be placed around inlet end of pipe.
- ③ 3" min. dia. pipe to be kept open for drainage of subgrade or base until surface is placed.

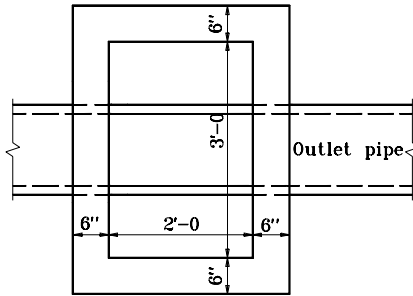

**PLAN**

**INLET TYPE M (CONC.)**

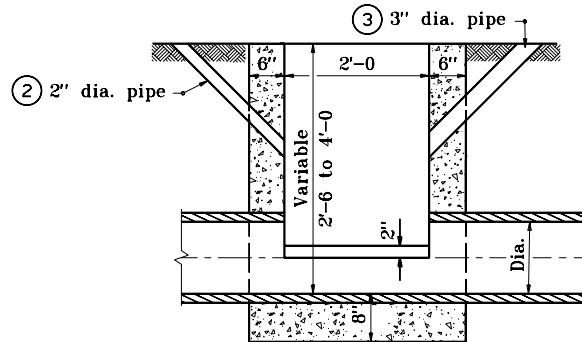

**SECTION**

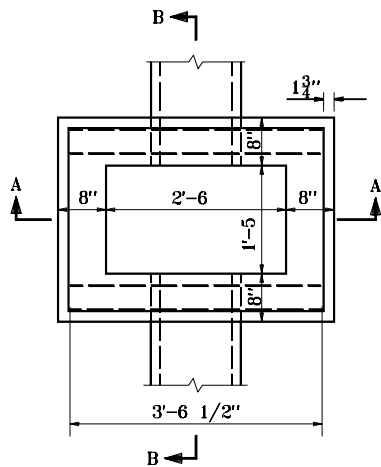

**SECTION A-A**

**INLET TYPE R (CONC.)**

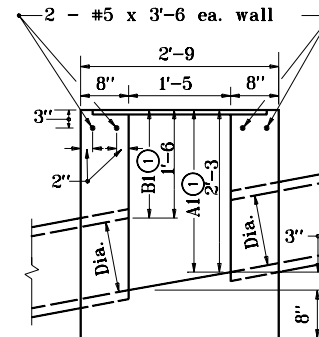
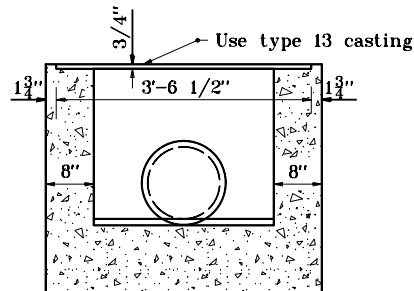

**SECTION B-B**

INDIANA DEPARTMENT OF TRANSPORTATION

**INLETS TYPE M AND R**

SEPTEMBER 1997

STANDARD DRAWING NO. **E 720-INST-07**

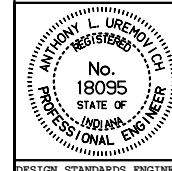

DETAILS PLACED IN THIS FORMAT 11-15-99

/s/ Anthony L. Uremovich 11-15-99  
DESIGN STANDARDS ENGINEER DATE

/s/ Firooz Zandi 11-15-99  
CHIEF HIGHWAY ENGINEER DATE

DESIGN STANDARDS ENGINEER

ORIGINALLY APPROVED 9-01-97