

United States Department of the Interior
National Park Service

National Register of Historic Places
Registration Form

FINAL
FILE COPY

This form is for use in nominating or requesting determinations for individual properties and districts. See instructions in *How to Complete the National Register of Historic Places Registration Form* (National Register Bulletin 16A). Complete each item by marking "x" in the appropriate box or by entering the information requested. If an item does not apply to the property being documented, enter "N/A" for "not applicable." For functions, architectural classification, materials, and areas of significance, enter only categories and subcategories from the instructions. Place additional entries and narrative items on continuation sheets (NPS Form 10-900a). Use a typewriter, word processor, or computer, to complete all items.

1. Name of Property

historic name The Buckingham

other names/site number 098-296-06040

2. Location

street & number 3101-3119 North Meridian Street N/A not for publication

city or town Indianapolis N/A vicinity

state Indiana code IN county Marion code 097 zip code 46208

3. State/Federal Agency Certification

As the designated authority under the National Historic Preservation Act, as amended, I hereby certify that this nomination request for determination of eligibility meets the documentation standards for registering properties in the National Register of Historic Places and meets the procedural and professional requirements set forth in 36 CFR Part 60. In my opinion, the property meets does not meet the National Register criteria. I recommend that this property be considered significant nationally statewide locally. (See continuation sheet for additional comments.)

Signature of certifying official/Title _____ Date _____

Indiana Department of Natural Resources
State of Federal agency and bureau

In my opinion, the property meets does not meet the National Register criteria. (See continuation sheet for additional comments.)

Signature of certifying official/Title _____ Date _____

State or Federal agency and bureau _____

4. National Park Service Certification

I hereby certify that the property is:

- entered in the National Register.
 See continuation sheet.
- determined eligible for the National Register
 See continuation sheet.
- determined not eligible for the National Register.
- removed from the National Register.
- other, (explain:)

Signature of the Keeper _____

Date of Action _____

The BUCKINGHAM
Name of Property

Marion County, IN
County and State

5. Classification

Ownership of Property
(Check as many boxes as apply)

- private
- public-local
- public-State
- public-Federal

Category of Property
(Check only one box)

- building(s)
- district
- site
- structure
- object

Number of Resources within Property
(Do not include previously listed resources in the count.)

Contributing	Noncontributing	
1	0	buildings
0	0	sites
0	0	structures
0	0	objects
1	0	Total

Name of related multiple property listing
(Enter "N/A" if property is not part of a multiple property listing.)

N/A

Number of contributing resources previously listed in the National Register

0

6. Function or Use

Historic Functions
(Enter categories from instructions)

DOMESTIC: Multiple Dwelling

Current Functions
(Enter categories from instructions)

DOMESTIC: Multiple Dwelling

7. Description

Architectural Classification
(Enter categories from instructions)

Tudor Revival

Craftsman

Materials
(Enter categories from instructions)

foundation BRICK

walls BRICK

STONE: Limestone

roof ASPHALT

other METAL: Tin

Narrative Description

(Describe the historic and current condition of the property on one or more continuation sheets.)

THE BUCKINGHAM
Name of Property

HAMILTON COUNTY, IN
County and State

Statement of Significance

Applicable National Register Criteria

Mark "x" in one or more boxes for the criteria qualifying the property for National Register listing.)

- A** Property is associated with events that have made a significant contribution to the broad patterns of our history.
- B** Property is associated with the lives of persons significant in our past.
- C** Property embodies the distinctive characteristics of a type, period, or method of construction or represents the work of a master, or possesses high artistic values, or represents a significant and distinguishable entity whose components lack individual distinction.
- D** Property has yielded, or is likely to yield, information important in prehistory or history.

Criteria Considerations

(Mark "x" in all the boxes that apply.)

Property is:

- A** owned by a religious institution or used for religious purposes.
- B** removed from its original location.
- C** a birthplace or grave.
- D** a cemetery.
- E** a reconstructed building, object, or structure.
- F** a commemorative property.
- G** less than 50 years of age or achieved significance within the past 50 years.

Narrative Statement of Significance

(Explain the significance of the property on one or more continuation sheets.)

9. Major Bibliographical References

Bibliography

(Cite the books, articles, and other sources used in preparing this form on one or more continuation sheets.)

Previous documentation on file (NPS):

- preliminary determination of individual listing (36 CFR 67) has been requested
- previously listed in the National Register
- previously determined eligible by the National Register
- designated a National Historic Landmark
- recorded by Historic American Buildings Survey # _____
- recorded by Historic American Engineering Record # _____

Areas of Significance

(Enter categories from instructions)

Architecture

Period of Significance

1909-1942

Significant Dates

1909

Significant Person

(Complete if Criterion B is marked above)

Rubush, Preston; Hunter, Edgar

Cultural Affiliation

NA

Architect/Builder

Rubush, Preston

Hunter, Edgar

Primary location of additional data:

- State Historic Preservation Office
- Other State agency
- Federal agency
- Local government
- University
- Other

Name of repository:

Indiana Historical Society

The Buckingham

Name of Property

Marion County, IN

County and State

10. Geographical Data

Acreege of Property 1.24

UTM References

(Place additional UTM references on a continuation sheet.)

UTM grid 1: Zone 16, Easting 572230, Northing 4407050

UTM grid 3: Zone, Easting, Northing

See continuation sheet

Verbal Boundary Description

(Describe the boundaries of the property on a continuation sheet.)

Boundary Justification

(Explain why the boundaries were selected on a continuation sheet.)

11. Form Prepared By

name/title Susan R. Slade

organization Slade Associates date May 5, 1992

street & number 4560 N. Broadway telephone 317/283-6114

city or town Indianapolis state IN zip code 46205

Additional Documentation

Submit the following items with the completed form:

Continuation Sheets

Maps

A USGS map (7.5 or 15 minute series) indicating the property's location.

A Sketch map for historic districts and properties having large acreage or numerous resources.

Photographs

Representative black and white photographs of the property.

Additional items

(Check with the SHPO or FPO for any additional items)

Property Owner

(Complete this item at the request of SHPO or FPO.)

name Buckingham Balmoral Historic Partners

street & number 5401 N. Pennsylvania telephone

city or town Indianapolis state IN zip code 46220

Paperwork Reduction Act Statement: This information is being collected for applications to the National Register of Historic Places to nominate properties for listing or determine eligibility for listing, to list properties, and to amend existing listings. Response to this request is required to obtain a benefit in accordance with the National Historic Preservation Act, as amended (16 U.S.C. 470 et seq.).

Estimated Burden Statement: Public reporting burden for this form is estimated to average 18.1 hours per response including time for reviewing instructions, gathering and maintaining data, and completing and reviewing the form. Direct comments regarding this burden estimate or any aspect of this form to the Chief, Administrative Services Division, National Park Service, P.O. Box 37127, Washington, DC 20013-7127; and the Office of Management and Budget, Paperwork Reductions Projects (1024-0018), Washington, DC 20503.

United States Department of the Interior
National Park Service

National Register of Historic Places
Continuation Sheet

Section number _____ photographs
Page 2

The Buckingham

- #12 Camera pointing west southwest, unit C, 3111 N. Meridian Street, living room with glazed porch. September 6, 1989.
- #13 Camera pointing northwest, unit D, 3105 N. Meridian Street, living room. September 6, 1989.
- #14 Camera pointing southwest, unit A, 3107 N. Meridian Street, living room with entrance hall through opening at center left.
- #15 Camera pointing north, unit C, 3119 N. Meridian Street, glazed porch
- #16 Camera pointing southeast, unit D, 3105 N. Meridian Street, dining room with kitchen door at center right, living room at center left. September 6, 1989.
- #17. Camera pointing northeast, unit A, 3107 N. Meridian Street, dining room, living room doorway at left.

United States Department of the Interior
National Park Service

National Register of Historic Places Continuation Sheet

Section number _____ photographs
Page 1

The Buckingham

PHOTOGRAPH INFORMATION

#1 The Buckingham, Indianapolis, Indiana,
Camera pointing east northeast, west elevation.
Bass Photograph, c.1911, neg. no. 25745
Indiana Historical Society

The following information is identical for all photographs except as noted:

The Buckingham
Indianapolis, Indiana
Susan R. Slade
June 19, 1989
Slade Associates, 4560 N. Broadway, Indianapolis, In., 46205

#2 Camera pointing east southeast, west elevation.

#3 Camera pointing northeast, west elevation of north wing.

#4 Camera pointing southeast, north elevation of south wing, west elevation of loggia.

#5 Camera pointing south southwest, north elevation of south wing, entrance to 3105 - 3107 N. Meridian Street.

#6 Camera pointing east northeast, west elevation of loggia, entrance to 3113 - 3115 N. Meridian Street at the left.

#7 Camera pointing southwest, rear east elevation.

#8 Camera pointing east southeast, entrance vestibule at 3117 - 3119 N. Meridian Street.

#9 Camera pointing west southwest, hall and stairway, 3101 - 3103 N. Meridian.

#10 Camera pointing southwest, unit C, 3119 N. Meridian Street, entrance hall with living room at right.

#11 Camera pointing west, unit A, 3111 N. Meridian Street, entrance hall looking into living room with glazed porch.

United States Department of the Interior
National Park ServiceNational Register of Historic Places
Continuation SheetSection number 7 Page 1 The Buckingham

Describe present and historic physical appearance.

Located at 3101-3119 N. Meridian Street, the Buckingham apartment building is a three-story, thirty-seven unit, Jacobethan Revival, U-shaped courtyard building with five main entrances (Photos 1, 2). Designed and constructed as a thirty unit building in 1909-10 by the successful firm of Rubush and Hunter, the Flemish bond brown-red brick building has limestone trim around all west elevation main openings and quoin edging on all corners. Sited parallel to N. Meridian Street, the Buckingham has a north and south wing connected by an arcaded loggia. The prominent west elevations of the projecting north and south wings are finished with four-sided turrets framing out a slightly recessed three-bay entrance facade (Photo 3). As originally finished, these polygonal corners were open porches. At an unknown date, these openings were infilled with multi-paned windows. The larger openings received non-operable panels; the narrower openings received six over six light double-hung sashes which repeat the configuration of the paired windows in the entrance facade. The three-bay entrance facade contains a segmentally arched, fifteen light centered entrance door which is flanked by sidelight panels. An eared, segmentally arched terne metal canopy with stepped flashing set against the brick wall projects over the door. Above the door and canopy is a slightly projecting oriel which extends through the second and third stories, and the high parapet which is prominently banded with terne metal at the top and bottom. Within the parapet level, a sculpted limestone panel with a centered heraldic shield extends the full width of the oriel. Atop the parapet, this composition is finished with a terne metal scrolled cartouche flanked and topped with terne metal obelisks.

The entrance to the courtyard is framed at the west end by the return of the four-sided corner turrets. Immediately adjacent and continuing down along the courtyard elevations of the north and south wings are straight-run concrete stairs which provide exterior access to the basement courtyard-facing units (Photo 4). The stairways are framed by a brick retaining wall which is topped by three brick piers with cast concrete caps. Pipe rails extend between the piers. At this intersection of the stairs and the courtyard, the elevations of the north and south wings project slightly so as to provide a corner band of quoins framing the four-sided end turret. This slight projection, two bays in width, is finished to the east with quoins which rise through the continuous banded parapet to frame a banded chimney. The elevation as it continues east, features five bays of double-hung, multi-paned windows in several sizes. This type of window arrangement is typical on all elevations. All original window openings have stone sills. To the east, the line of the five-bay section of the courtyard elevation is broken by a three-story, three-part, original open porch projecting bay (Photo 5). The three-part openings have been infilled with multi-paned windows as those on the west ends of the wings. The courtyard elevation continues east to end with the two bay section which contains another

United States Department of the Interior
National Park Service

National Register of Historic Places
Continuation Sheet

Section number 7. Page 2

The Buckingham

primary entrance. This entrance is detailed as those to the west.

The east end of the courtyard is finished with a three-story, five bay, arcaded loggia, the connector between the north and south wings (Photo 6). The two-story loggia piers and accompanying round arches are veneered with ashlar limestone. All window openings in this elevation were originally open as porches. They have been infilled with multi-pane units. The first story openings have a centered, multi-pane door with toplight. The deeply recessed primary entrance is fitted with the fifteen-light, segmentally arched door. Wood spandrels, each with three, horizontally arranged panels framed with raised moldings, separate the first story from the second within the two-story arches. The second and third story infill windows are set with a centered casement unit flanked by fixed multi-pane units. The loggia is finished with a projecting open eave, red tiled shed roof which is supported by two wrought iron "C" brackets. The eave is finished with exposed rafters with sawn curved ends.

The entire main facade treatment recalls the English country house tradition with its obvious symmetry and enlarged openings of the Elizabethan period and the open courtyard and robust curvilinear forms of the arches, canopies and parapet sculpture of the Jacobean period. This same juxtaposition of medieval and baroque forms is seen in the English Arts and Crafts movement: the medieval forms boldly translated by Richard Norman Shaw and his contemporaries and proteges such as Philip Webb and Ernest Newton with interiors by William Morris and the more restrained Edwardian view of the country house as exemplified in the late nineteenth century work in Surrey by Sir Edwin Lutyens.

The north, south and east elevations of the building proper are finished in a far less decorative, more utilitarian manner (Photo 7). The banded parapet converts to a simple metal parapet cap. There is no limestone detailing. Multi-paned paired and three-part casement windows are located on the east and rear south and north above-grade basement elevations. At the alley, basement level east elevation windows have been covered with plywood for security. The single leaf alley doorway is fitted with an unglazed door. Other rear doors providing access to the rear stairwells and basement work areas are paneled with upper multi-pane lights.

The five main entrances feature wood, multi-light, segmentally arched doors which are flanked by narrow sidelights. The doors open into small marble finished floor, wall and ceiling vestibules. Annunciator panels and mailboxes are installed in the walls (Photo 8). A similarly detailed door opens into the narrow stairhall. The hall and stairwell are finished with Arts and Crafts flat-sawn, pierced oak strip wainscot which is applied to the plaster walls (Photo 9). A heavily molded rail finishes the upper edge of this abstracted

United States Department of the Interior
National Park Service

National Register of Historic Places Continuation Sheet

Section number 7. Page 3

The Buckingham

linenfold paneling. The stair rails are finished with two-part pierced oak balusters. Broad, flat, paneled, hip-capped newel posts mark the landings. Two-panel oak entry doors are finished with individually designed stained and leaded glass upper panels. Each panel features an heraldic emblem surrounded by geometric borders of different colored and textured glass. The doors are set in slightly recessed, flat, unmolded door frames which are capped with a slightly projecting crown molding. All wood is oak, darkly stained.

The Rubush and Hunter's architectural development of the apartment unit plans was thoroughly and practically achieved. Each of the five main entrances is similar to a single Eastern flat building. A double-loaded stairhall with ample light provides access to two identical units per floor.

In a typical unit, the front entry door opens into an entrance hall (Photo 10). The large living room is located toward the courtyard (Photos 11, 12, 13, 14). The major decorative feature of the living room is the slightly projecting gas fireplace. Flat oak trim and mantle frame the Rookwood-like tile surround and hearth. A French door opens from the living room to the fully glazed solarium (Photo 15). The concrete floor, bare, vinyl or marble tiled, exposed scupper detail and painted brick walls are evidence of the original open porch. The date of the installation of the multi-paned windows is unknown. The social core of the apartment is completed by the dining room (Photos 16, 17). This room is finished in the full Arts and Crafts style, similar to the stairhall. Pierced oak wainscot is applied to the plaster walls. Wood cased beams finish the ceiling. A variety of pendent chandeliers hang from the center beam. Original Arts and Craft bronze repousse fixtures and matching drop lights installed at the four corners remain in some units. The utilitarian core of the unit is centered around the rear hall and kitchen which also can be entered from the dining room. Two large bedrooms and full bath are located away from the courtyard. The maid's room with attached half-bath opens from the kitchen. The kitchen features a mixture of original cabinets, usually in a pantry configuration, with newer cabinets in the work area. The enclosed utilitarian rear stairway exits from the kitchen. The stairways terminate adjacent to an exterior basement door or into a basement corridor. The included five original unit plans further amplify the full separation of formal living space from the sleeping and service areas.

The basement is a rabbit warren of small spaces due to the brick load-bearing foundations. The caretaker's unit was located at the southeast corner of the building. In 1930, Paul L. White is recorded as having a decorating business in the building. No specific address is cited, nor is he listed as a resident. By the 1970's, there were five apartment units in the basement. Drywall, plastic laminate and plywood paneling in place in 1983 indicate that the four

National Register of Historic Places Continuation Sheet

Section number 7. Page 4

The Buckingham

west end units were those most frequently in use. The remainder of the basement contains the laundry facilities, ample storage spaces, workrooms, and a former maid's bathtub room and boiler room.

The Buckingham is sited parallel to North Meridian Street, today a busy, four-lane thoroughfare. A two-car deep parking lot separates the west entrances and north-south sidewalk from the public sidewalk. Originally a semi-circular drive from North Meridian Street approached the courtyard. The parking lot was a formally landscaped, sunken garden which featured stone benches and a centered stone Sullivanesque fountain. An east-west sidewalk extends through the courtyard to the rear west elevation entrance. Original low brick stone capped walls set with urns approach this walk from the flanking wings of the courtyard. The rear elevation is sited to the alley. On this elevation, the basement is totally exposed. A one story, flat roofed, detached six-bay garage was constructed at the alley on the southeast corner of the lot at an unknown date (See Photo 7). Since Preston C. Rubush as designer, builder and occupant was one of the founding members of the Hoosier Automobile Club and served as its vice-president in 1925, and that he included a four-bay garage at his Wisconsin summer home, 1930-31, it is reasonable to assume that this building was constructed within the period of significance.

The current owners have completed a conditionally approved substantial rehabilitation. The general scope of work included removal of extensive ivy and pressure wash of exterior brick and limestone. Selective tuckpointing was completed. Existing windows and storm/screen units were repaired and repainted. All terne metal elements, entrance canopies and parapet ornamentation, were repaired, sealed and repainted. On the interior, all entrance vestibules, hallways, staircases and unit entry doors were repaired as needed, the original historic fabric being duplicated when necessary. In the original thirty units, each was treated individually. All units received individual gas heat/air conditioning units installed in the front entrance closets. All ductwork was installed in lowered hall ceilings and living room bulkheads. Where bulkheads interfered with original crown molding, molding was removed and reinstalled at the ceiling/bulkhead line. All hardwood floors were refinished. All matte tile fireplace surrounds were repaired. If tile had been removed or painted, existing finishes were cleaned and repaired. All trim and dining room wainscot, beams and existing light fixtures were repaired as required and original wood finishes restored. All kitchens and baths were retained in existing locations. Existing pantry cabinets were repaired and repainted. New appliances, countertops and work area cabinets were installed. New vinyl flooring was installed. In baths, existing tile was repaired, existing fixtures repaired, reglazed or replaced. All windows opening to rear stairwell were infilled with painted gypsum panels. All rear entrance doors were replaced with solid fire-rated doors. Existing modifications for apartment units in the basement were removed. Three new units were created in each of the west wing basements. The original custodian's unit was relocated to the northeast corner of the basement. Finishes in these units do not replicate those in the original units. Basement storage areas and large laundry room were updated with new equipment and security control. As rehabilitated, the Buckingham contains thirty-seven apartment units.

United States Department of the Interior
National Park ServiceNational Register of Historic Places
Continuation SheetSection number 8 Page 1 The Buckingham

The Buckingham is a thirty-seven unit Jacobethan Revival styled courtyard apartment building, U-shaped in plan. As an early and outstanding Indianapolis example of this style applied to a developing building type, the courtyard apartment, the Buckingham meets the National Register Criterion C in the area of architecture. The Arts and Crafts details of the interior public and unit primary living spaces further characterize the completeness of the architectural expression. Designed, constructed and owned in 1909-10 by the prestigious, local architectural firm, Rubush and Hunter, this building documents the firm's noted achievement in design consistency and craftsmanship. Preston C. Rubush (1867 - 1947) and Edgar O. Hunter (1873 - 1949) selected individual units at the Buckingham upon its completion and continued to reside there until their deaths. As their residence for 37 and 39 years respectively, Rubush and Hunter's Buckingham meets the National Register Criterion B. With its gracious, spacious entrance courtyard, loggia, fine architectural detailing and North Meridian Street address, the Buckingham quickly became one of the city's premier apartment buildings.

In 1904, two practicing Indianapolis architects joined forces to establish a firm that quickly succeeded in receiving commissions for important, highly visible buildings. (1) Castle Hall, Knights of Pythias, 230 E. Ohio Street (1905) and Knights of Pythias Lodge No. 56, 127 E. Ohio Street (1906), represent the firm's early commercial work. Both main elevations are strongly and tightly framed with Gothic Revival/Tudor Revival details such as hexagonal side towers connected with prominent battlements which surround paired Tudor arched multi-storied window frames at Castle Hall and quoins and similar battlements which cap a two-story fully glazed centered oriel at the Lodge.

By 1908 - 09, the firm was engaged in design and construction of the Old Indianapolis City Hall (NR 10-29-74) and the Masonic Temple, 535 N. Illinois Street. Both buildings feature finely detailed limestone facades in the Neoclassical style. Commissions for large commercial office buildings such the Illinois Building, 17 W. Market Street and the Hume-Mansur Building, now demolished, were on the boards in 1910 and 1911. Beaux Arts designs for both buildings were embellished with marble panels, sculpture and prominent bronze hanging lamps for the Illinois Building and a robust display of terra cotta facing for the Hume-Mansur Building, an eleven-story, speculative office building located on the south side of E. Ohio Street between N. Pennsylvania and N. Meridian Streets. As the largest office building in the city center between 1911 and the 1940's, it served as the largest center of the medical profession in the state with its profusion of doctors' and dentists' offices and associated pharmacies and oculists.

United States Department of the Interior
National Park ServiceNational Register of Historic Places
Continuation SheetSection number 8. Page 2

The Buckingham

It is the firm's work between 1915 and 1930 that establishes Rubush and Hunter as the premier firm noted for expertise in developing extremely functional and spacious plans for a variety of building types including offices, theaters, clubs, a hotel and department store. In design, each project reflects finely detailed and executed finishes which enhance the historic antecedents upon which the over-all scheme was based. The following buildings designed by the firm are listed in the National Register of Historic Places as significant for their architecture: Circle Theatre (1916), a terra cotta Roman temple; Reserve Loan Life Insurance Company (1925), a white marble Neoclassical business headquarters; Columbia Club (1925), a limestone Collegiate Gothic Republican stronghold; Taylor Carpet Building (1925), stone Renaissance Revival facade; YWCA Blue Triangle Residence Hall (1927), a brick Second Renaissance Revival dormitory; Madame C.J. Walker Building (1927), a brick and terra cotta Art Deco office and theatre complex; Indiana Theater (1927-1929), a terra cotta Spanish Baroque Revival movie palace. The following Rubush and Hunter buildings located in historic districts are also included in the National Register: 3312 Washington Boulevard (1907), Mission Revival house, Meridian Park Historic District; Kothe, Wells and Bauer Company (1908-1909), Renaissance Revival office and warehouse, Indianapolis-Union Station Wholesale District; The Blenheim (1907), Twentieth Century Functional/Craftsman apartment building, Herron-Morton Place Historic District; George Gaye House (1911), Tudor Revival mansion, Meridian Street Historic District; First United Brethern Church (1921), English Gothic Revival church, Chatham-Arch Historic District; Coca-Cola Bottling Company (1931), a terra cotta Art Deco office and manufacturing plant, Massachusetts Avenue Historic District. In addition to the early Knights of Pythias buildings, the Masonic Temple and the Illinois Building mentioned above, the following buildings designed by the firm have been designated as outstanding for architecture in the Center Township, Marion County Inventory: Ko-We-Ba Pure Foods (1918), a brick Twentieth Century Functional office and warehouse; Guaranty Building (1922-1923), a limestone Renaissance Revival office tower; Circle Tower (1929-1930), a limestone Art Deco office building; American United Life Building (1931), a limestone Neoclassical insurance company headquarters; H.P. Wasson and Company (1936-1937), a polished granite Art Deco department store.

The broad range of architectural styles represented in the above list clearly characterizes the work of the firm of Rubush and Hunter. That the work is so highly visible cannot be questioned. Specifically, the four buildings located on Monument Circle, the Columbia Club, Circle Tower, Circle Theater and the Guaranty Building not only represent the range of styles, but also reveal the use of stylistically appropriate details wrought in a variety of materials. The enclosed, yet open nature of this Circle, the historic center of the original 1821 plan for the city of Indianapolis and today accented by Indiana State Soldiers' and Sailors' Monument (NR 2-23-73), offers the pedestrian unbroken

United States Department of the Interior
National Park ServiceNational Register of Historic Places
Continuation SheetSection number 8. Page 3

The Buckingham

vistas of all the facades and the opportunity to experience by touching the ashlar limestone finish of the Columbia Club, the limestone carving of the papyrus reed bundles of the Circle Tower's grand entrance arch and the cool white glazed terra cotta pilaster panels flanking the canopy of the Circle Theater. Of the ten buildings which surround the monument, four were designed by Rubush and Hunter.

Although the Tudor Revival and Jacobethan design elements were perfectly suited for the social and business functions of the Knights of Pythias fraternal benefit society, individually Rubush and Hunter preferred these design motifs for their own residences which were both designed and built in 1906 - 07. Preston C. Rubush designed a Tudor Revival/Craftsman house for himself and family. An open gable roof with wide overhanging eaves features a multi-sided turret with battlements.(2) In 1907, Edgar O. Hunter designed and built a brick six-unit Eastern flat building for himself and other members of his family. The Blenheim, although without specific stylistic references to the Tudor Revival, maintains a strong elevation consisting of brick piers faced with wall buttresses which frame the projecting two-story porch. Craftsman detailing in the interior includes boxed beamed ceilings and vertically applied flat oak boards simulating a high wainscot which is finished with a narrow plate shelf. All living room fireplaces are finished with a surround of Rookwood tiles.(3)

For the development of the Buckingham, Edgar O. Hunter purchased Lots 3 and 4, Osgood's Meridian Park Addition, from Ida Osgood Stanley, November, 1908. Six days later, he sold his previous residence, the self-designed and contracted six-unit Eastern flat, to Mrs. Stanley. The final purchase agreement for Lots 4 and 5 is dated June 7, 1909. Financing and design began by mid 1909. Construction was underway when Hunter sold an undivided half interest in the building to his partner, Preston C. Rubush, on July 23, 1910. Additional funding was gained through a mortgage from Provident Life and Trust Company, Philadelphia, to Hunter for \$75,000, September 29, 1910. Construction was completed by late 1910. Indianapolis City Directory of 1911 shows both Rubush and Hunter living at 3109, apartments D and F respectively (see Buckingham Key Plan). Both maintained residences in the complex until their deaths.

The Buckingham design, plan and interior finishes were developed by Rubush and Hunter as the "Family Hotel Building" (4). The west courtyard elevation provided a gracious entranceway landscaped with brick walls topped with urns. A curved drive from Meridian Street approached the north and south projecting wings. A sunken, formally landscaped garden was located between the drive and the street (see Photo 1). Steps from the garden approached the courtyard of the building. Greenery was contained on the building as an extension of the

United States Department of the Interior
National Park ServiceNational Register of Historic Places
Continuation SheetSection number 8. Page 4

The Buckingham

landscaping; flower boxes were placed beneath the west openings of the loggia. Many of the open porches of the west wings also had window boxes located on the sills of the originally unglazed openings.

The exterior architectural treatment of the Buckingham is in the Jacobethan Revival style. The symmetrically arranged facades with flat roofs, bay projections framed in limestone quoins and balanced and open fenestration presents an English country house view of the integrated landscape plan. Historical references to the long gallery and heraldic crest of the resident family present in the centered limestone shields framed with an intricate composition of terne metal obelisks rendered an idyllic, picturesque estate scene on North Meridian Street. Although it has come to light that personally, both Rubush and Hunter preferred this style for their own residential settings, apartment buildings in the city of Indianapolis in 1910 were not designed using this style, a mode more closely associated with the next north phase of residential development and after 1916. Specifically, the apartment block located at the southwest corner of E. 38th Street and N. Pennsylvania Street, 37-39 E. 38th Street and Oxford Gables, 320 E. 38th Street are both outstanding examples of this architectural style built after 1916.

The Buckingham was the first courtyard complex built on North Meridian Street between Fall Creek (2400 N.) and 38th Street. As early as 1890, North Meridian Street had become the address street in the city. Large, eclectic revival, single-family dwellings, the household centers of Indianapolis' wealthy, were sited with ample set-backs on large, open lots. In Osgood's Meridian Park Addition, which was composed of more than thirty-nine acres between 30th and 32nd Street on the east side of North Meridian Street, only one large brick residence had been constructed by 1908. Between 1910 and 1915, the Buckingham was surrounded by undeveloped open space, nearly four hundred feet to the north, south and east. By 1916, only the Balmoral Court, located immediately south of the Buckingham, had adopted the plan of the courtyard as an integral part of the development of an apartment complex (5).

At the Buckingham, the interior detailing, elaborate in the public spaces of both the entrances and the individual units, continues the English historical tradition established on the exterior. Here the interpretation, although initially inspired by the English Gothic Revival to maintain or recreate the vernacular mode in interior architecture, results in flattened, simplified forms which could be worked easily by hand, but were also readily fashioned by machine. From this ethic developed the English Arts and Crafts Movement of the 1880's. By 1900, American architectural design and interior finishes and furnishings under the leadership of Frank Lloyd Wright and Gustav Stickley had embraced the same aesthetic. The Arts and Crafts styled sawn oak wainscot applied to the plaster walls of the entrance hallways and dining rooms simulates in its open pattern, an abstract linenfold paneling. This same stylistic treatment is continued in the broad, flat, pierced balusters of the hallway stairs and in flat trimmed, slightly recessed unit entrances. The leaded

United States Department of the Interior
National Park Service

National Register of Historic Places
Continuation Sheet

Section number 8. Page 5

The Buckingham

stained glass entrance door panels feature a variety of centered motifs including shields, lamps and sailing ships surrounded by obscure glass panels. Within the individual units, the same decorative applications are further simplified and enhanced. Closely spaced, flat vertical pierced boards are applied to the plaster walls of the dining room. A plate rail serves as a cap to this paneling. Exposed flat cased beams and geometrically leaded obscure glass panels in the door to the kitchen/pantry complete the ensemble. In the living room, the center focus is the large, slightly projecting matte glazed tile fireplace surround capped with a mantel shelf. This feature not only visually repeats the historic necessity, but also references an amenity usually associated only with single family dwellings. Once again, Rubush and Hunter have taken an historical reference, adapted it to suit a different building type, an apartment building, while consistently maintaining the context of the source of the design. (6)

The early residents included leaders and family members of Indiana's capital city. In 1914, the largest or west end apartments were occupied by O. P. Ensley, city real estate investor and officer of the Foster Lumber Company and Frederick Gregory, partner in the leading insurance, real estate rental and loan firm in the city. Sisters, Hannah A. Mansur and Mary E. Hume, lived across the hall from each other. They were mothers of cousins George Hume and Charles Mansur, the developers of the large Hume-Mansur Building designed by Rubush and Hunter while the Buckingham was also under development. Indeed, these two widows left their adjacent homes, the building site of the Hume-Mansur Building, and provided the financing for the project. Based on this connection, Rubush and Hunter were given the design commission for the American United Life Insurance Company Building, N. Meridian Street at Fall Creek in 1930-31. George Hume was treasurer of American Central Life Insurance Company, the parent company of A.U.L., at the time of the company's expansion and need for new offices. H. M. Foltz, Indianapolis architect whose customized Arts and Crafts office was legendary in the city, lived on the first floor beneath Mary E. Hume. Foltz as dean of city and state architects later became the chief of the Historic American Buildings Survey team in Indiana, 1933.

The Buckingham, with individual maid's quarters, large two-bedroom apartments which totaled nearly 1900 square feet of living space, became the residence of well-established, monied Indianapolis families. The elaborate and unique Jacobethan Revival/Arts and Crafts finished apartment building designed, developed and owned by the established architectural firm of Rubush and Hunter offered custom-designed, single-family residential characteristics to its tenants.

National Register of Historic Places Continuation Sheet

Section number 8. Page 6

The Buckingham

Endnotes

(1) Preston C. Rubush was a lifelong resident of Indianapolis. Rubush studied at the University of Illinois. By 1895, he was associated with John H. Scharn, Scharn and Rubush, architects. In 1903, Rubush listed his firm as the P.C. Rubush and Company, successor to Scharn and Rubush. In 1904, P.C. Rubush and Company became Rubush and Hunter when Rubush became associated with Edgar O. Hunter. Hunter was born in Versailles, Indiana. He studied architecture at the University of Pennsylvania. He was a draftsman for Vonnegut and Bohn, a leading architectural firm in Indianapolis (The Athenaeum, NR 2-24-73) before associating with Rubush.

(2) P.C. Rubush House, 2743 N. College Avenue, has been designated as a notable example of architecture in the Indiana Historic Sites and Structures Inventory. In the selection of this site, Rubush might have been persuaded to locate immediately across the street from Fall Creek. Before flood control and lack of maintenance, Fall Creek offered Indianapolis residents opportunities for boating. In 1916, Preston Rubush was the vice president of the Indianapolis Canoe Club. At the time of his death in 1947, he owned a summer cottage in Three Lakes, Wisconsin, heart of the chain of lakes in the north central part of the state.

(3) The Blenheim has been certified by NPS-MARO as a building which contributes to the significance of Herron-Morton Place Historic District for the purpose of rehabilitation.

(4) The Rubush and Hunter Collection, Architectural Archives, Historical Society has thirty-three sheets of plans, elevations, sections and details so identified. It is not known when the name "Buckingham" was assigned to the building.

(5) According to the Baist Real Estate Atlas of Surveys of Indianapolis and Vicinity, 1916, no large-scale courtyard apartment buildings other than the Buckingham and Balmoral Court were located between Fall Creek and the south side of 38th Street, east of N. Meridian Street. Between 30th Street and 38th Street, N. Meridian Street and Washington Boulevard, The Esplanade, 1913, (NR 6-16-83), The Esplanade Annex, 1912, Meridian Park Historic District, and a group of three small frame and stucco buildings located on the south side of 36th Street at Washington Boulevard are the only multiple dwelling units so constructed identified.

(6) At this time, three other Indianapolis apartment buildings built between 1905 and 1913, have been identified as having significant Arts and Crafts or

United States Department of the Interior
National Park Service

National Register of Historic Places Continuation Sheet

Section number 8. Page 7.

The Buckingham

Craftsman interiors. The most comparable to the Buckingham is the interior of the Esplanade. Located immediately to the east of the Buckingham, the apartment units are finished more in the American interpretation of the English Arts and Crafts Movement. Details here are similarly located, wainscot, leaded stained glass windows and tile fireplace surrounds. These elements are simplified and correspond in style to the Craftsman exterior. The Blenheim (see above) and the Coulter Flats (NR 5-31-90) have interior finishes in the dining room which are similar to each other. The exteriors of the buildings are similar in plan only. The architectural stylistic statements differ dramatically. The Coulter Flats is designated as a Jacobean Revival styled apartment building.

United States Department of the Interior
National Park Service

National Register of Historic Places Continuation Sheet

Section number 9,10 Page 1 The Buckingham

9. Bibliographical References

Baist, G. William (compiler). Real Estate Atlas of Surveys of Indianapolis and Vicinity, Indiana. Philadelphia: G. William Baist, 1899, 1908, 1916, 1927.

Casler, Patricia R. "The Architecture of Rubush and Hunter." Master's Thesis, Graduate School of Architecture and Planning, Columbia University, 1985.

Chain of Title. Marion County Clerk's Office.

Indianapolis City Directory. R. L. Polk and Company, 1870 - 1970.

Indianapolis Times. February 12, 1950.

10. Geographical Data

Verbal Boundary Description

Lots 4 and 5, Osgood's Meridian Park Addition, City of Indianapolis. The dimensions of the nominated property are 193.42' X 280'.

Boundary Justification

The boundary includes two complete city lots. The building is centered on the property within two feet of the north and south lot lines.

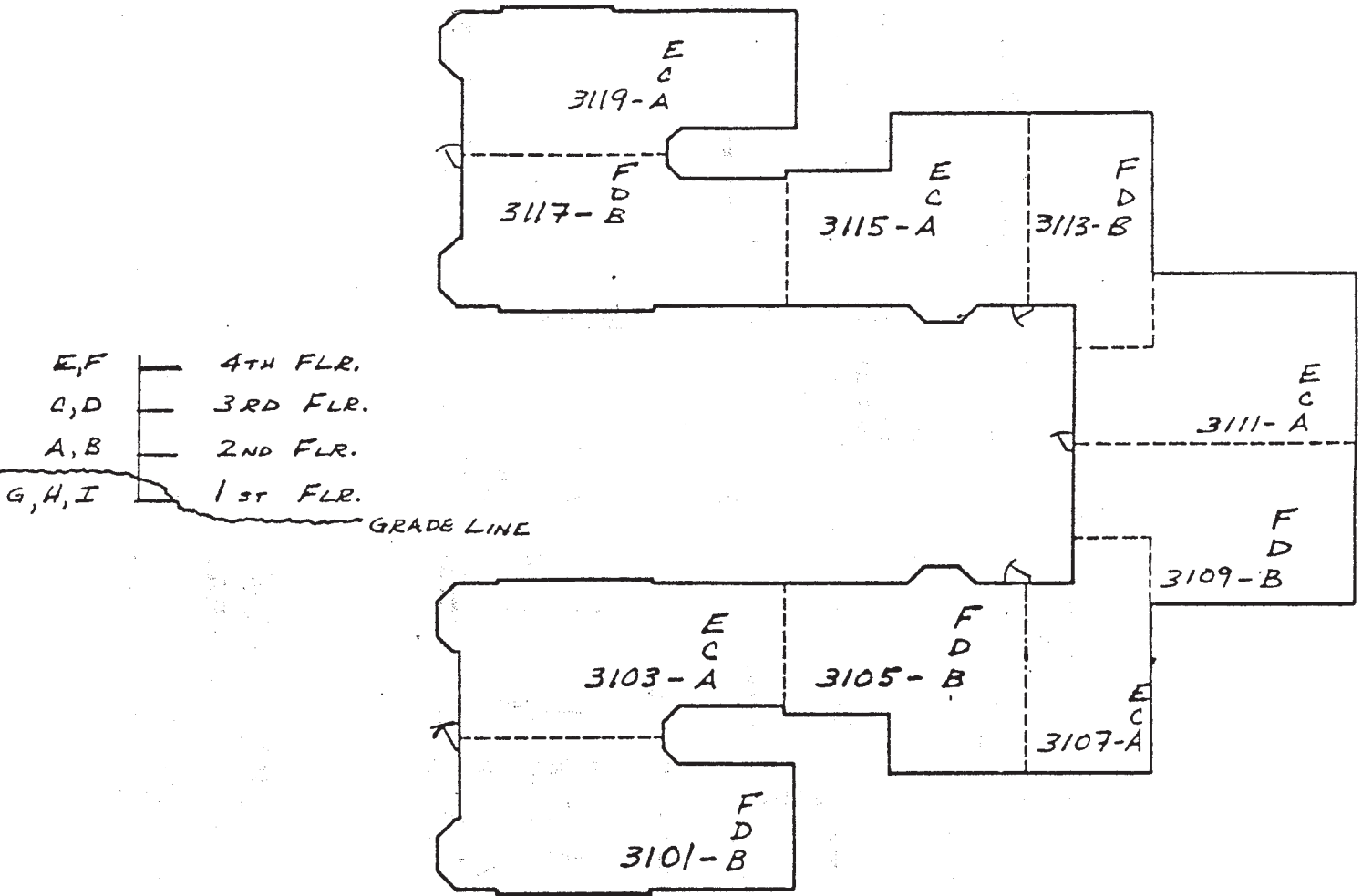

BUCKINGHAM APARTMENTS KEY PLAN

3101 - 3119 N. MERIDIAN ST.

FLOORS 2-3-4

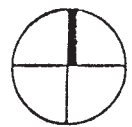

Unit 1 - 2 Bedroom plus Den.....	1815 s.f.
Unit 2 - 2 Bedroom plus Den.....	1343 s.f.
Unit 3 - 2 Bedroom plus Den.....	1349 s.f.
Unit 4 - 2 Bedroom plus Den.....	1519 s.f.

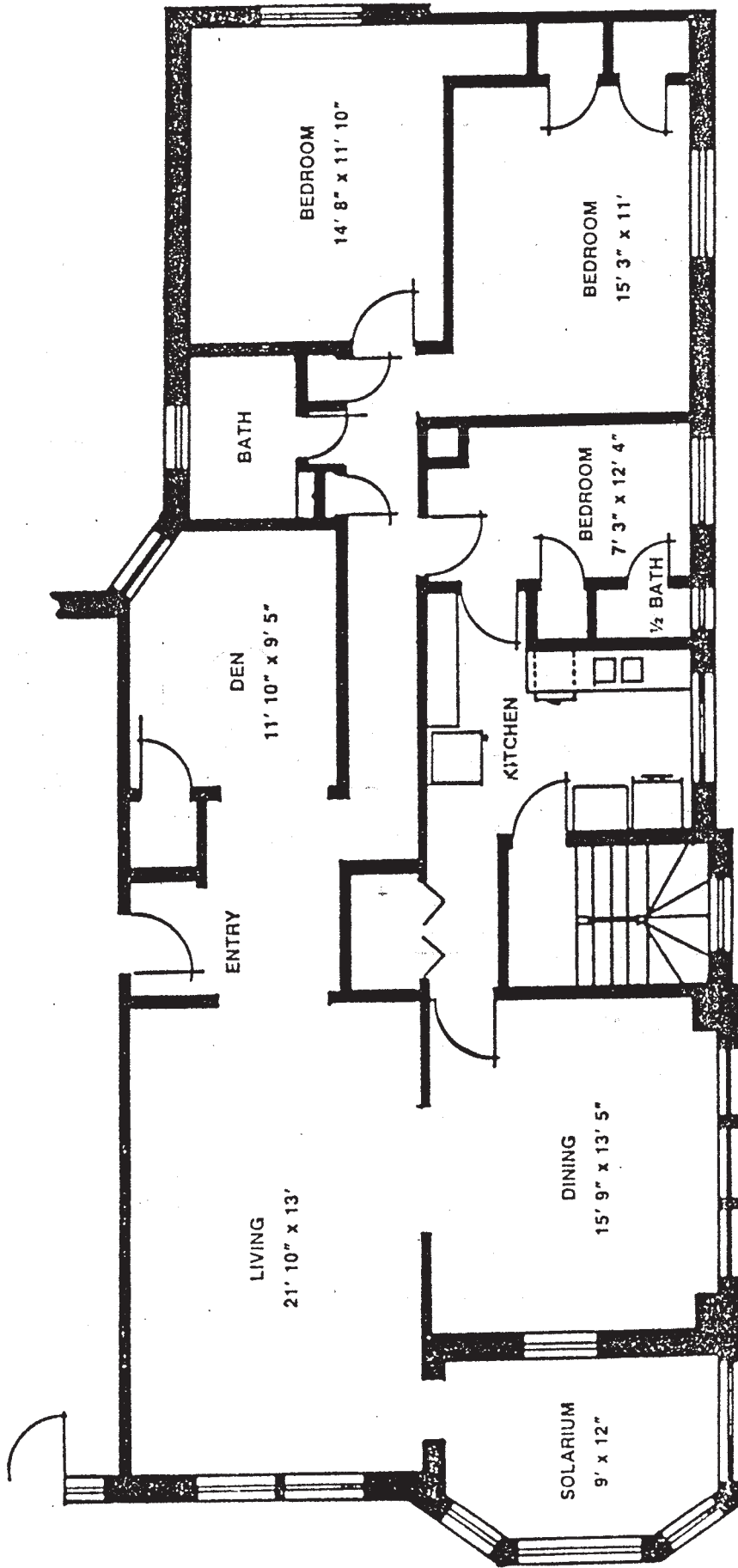

BUCKINGHAM
3 BEDROOM/DEN/1 1/2 BATHS

1815 sq.ft.

Units B, D, F 3101 North Meridian, Units A, C, E 3103 North Meridian
Units B, D, F 3117 North Meridian, Units A, C, E 3119 North Meridian

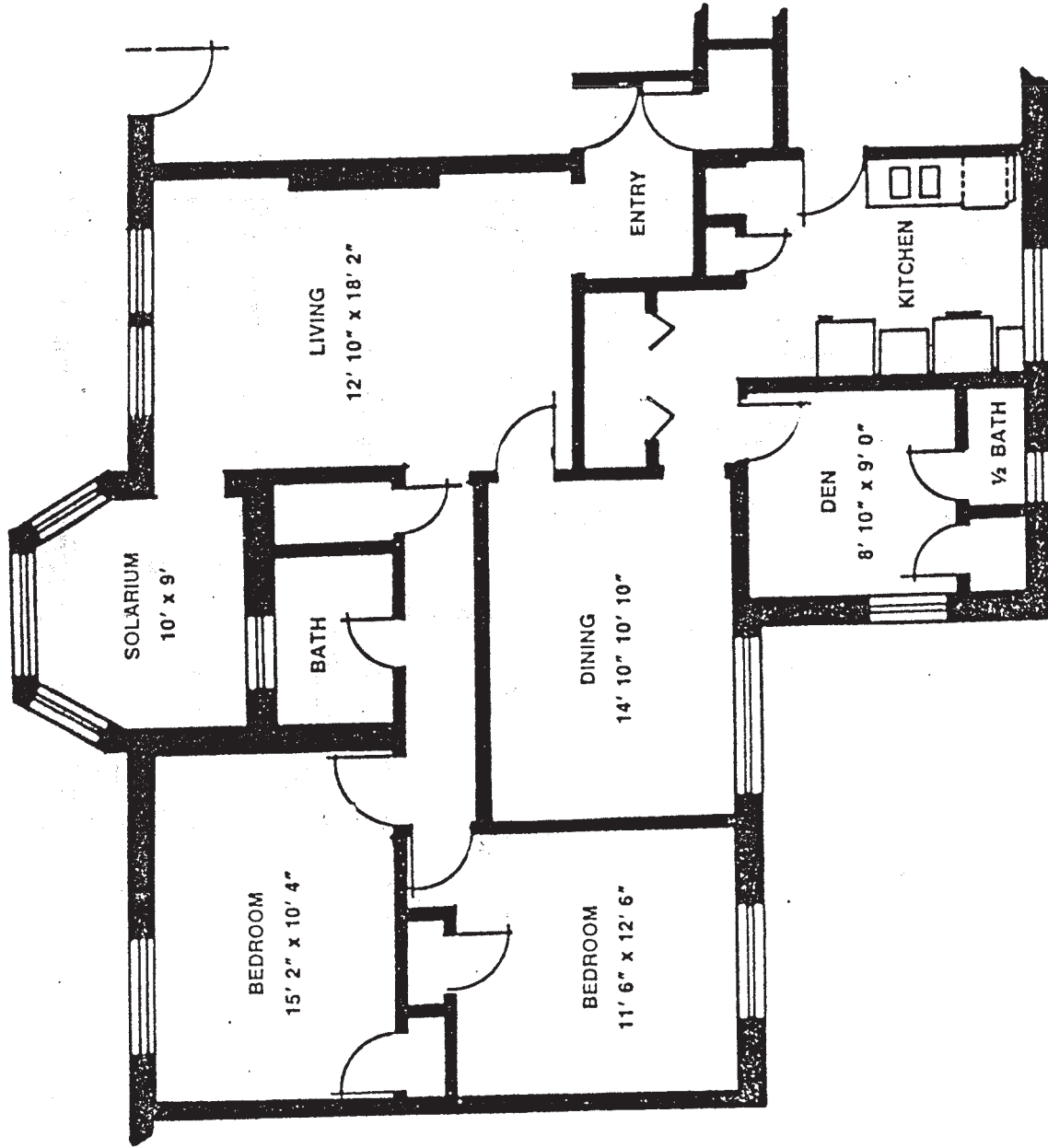

BUCKINGHAM
2 BEDROOM/DEN/1½ BATH
1343 sq. ft.

Units B, D, F 3105 North Meridian
Units A, C, E 3115 North Meridian

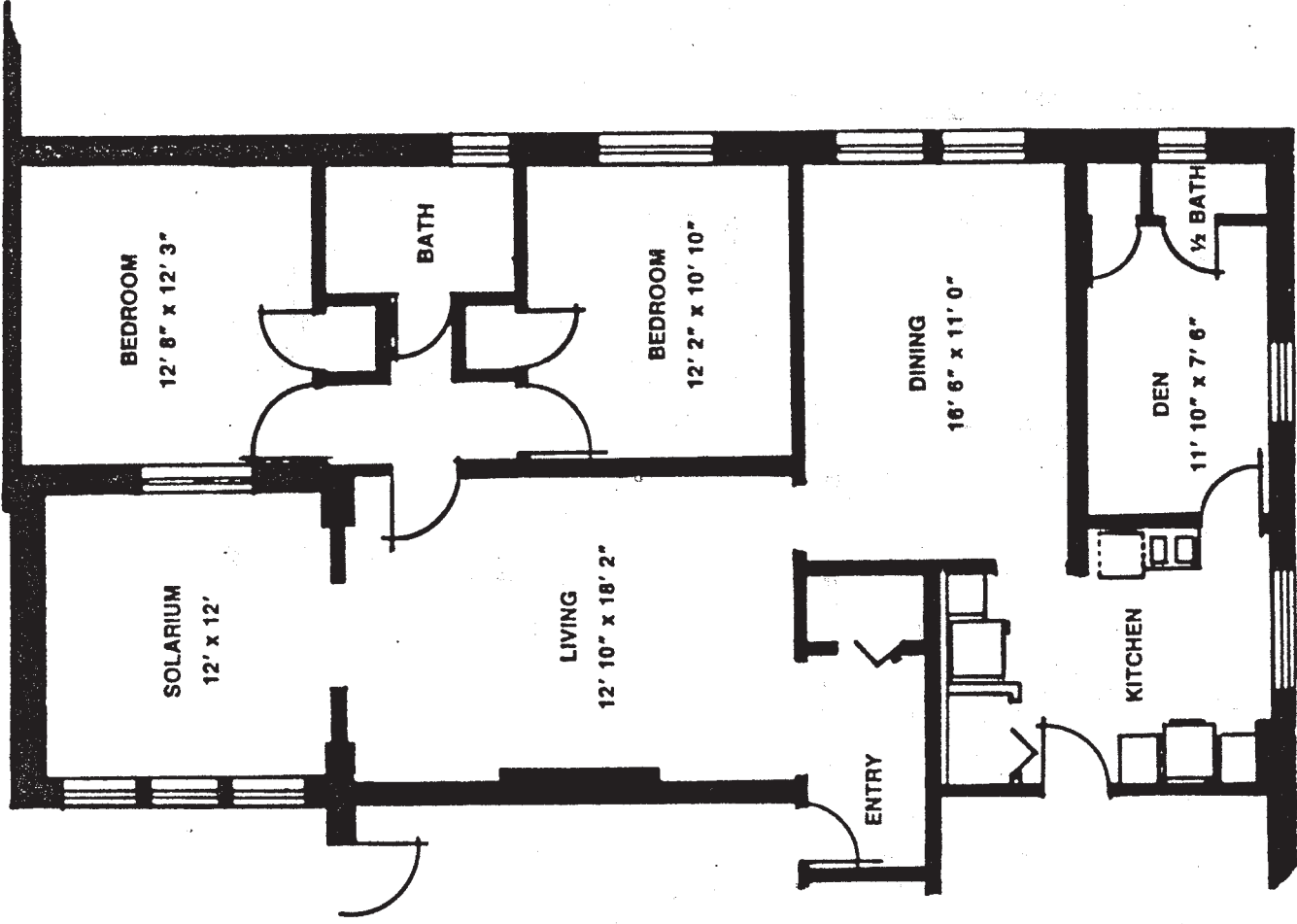

BUCKINGHAM
2 BEDROOM/DEN/1½ BATH
1349 sq. ft.

Units A, C, E 3107 North Meridian
Units B, D, F 3113 North Meridian

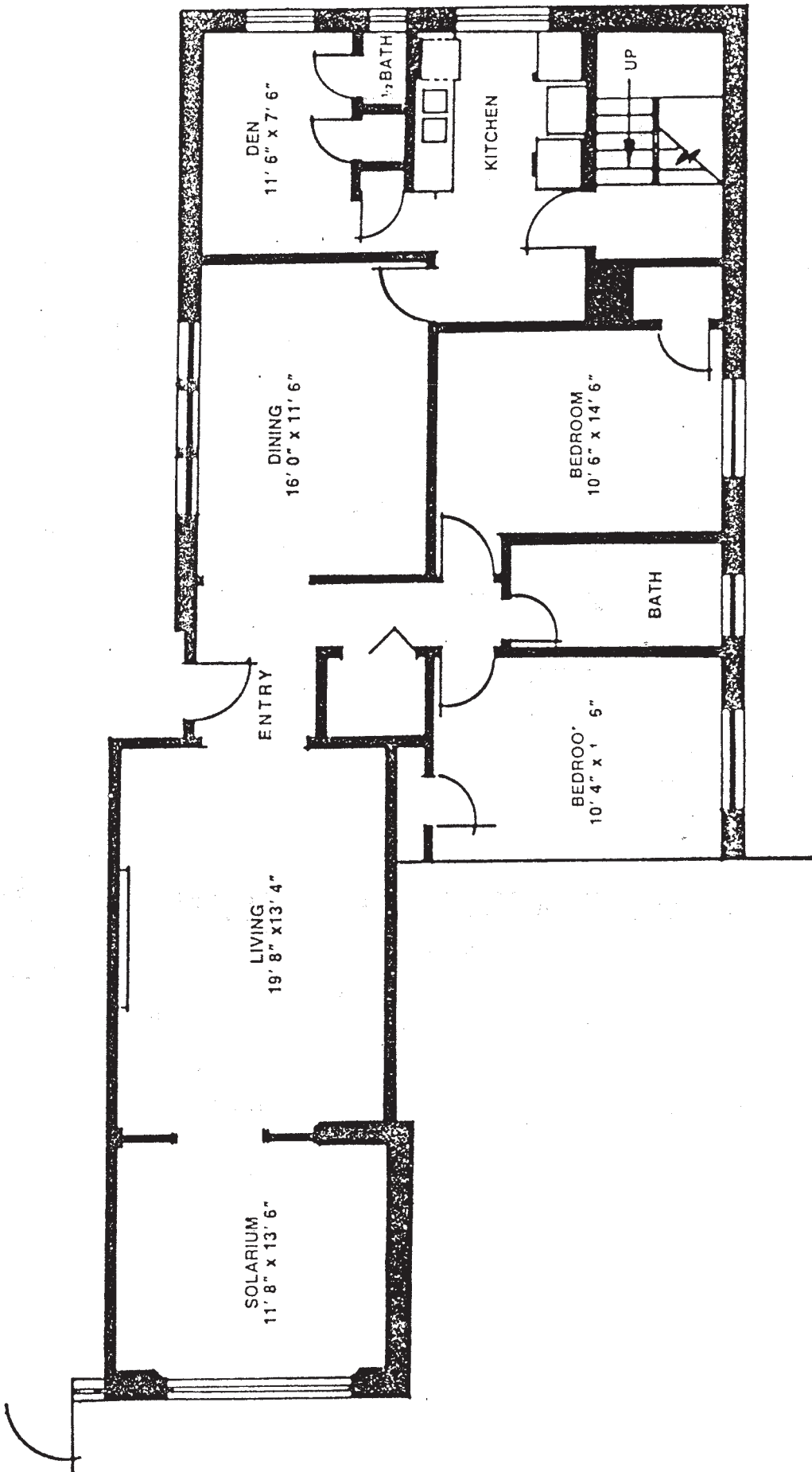

BUCKINGHAM
2 BEDROOM/DEN/1½ BATH
1519 sq. ft.
Units B, D, F 3109 North Meridian
Units A, C, E 3111 North Meridian

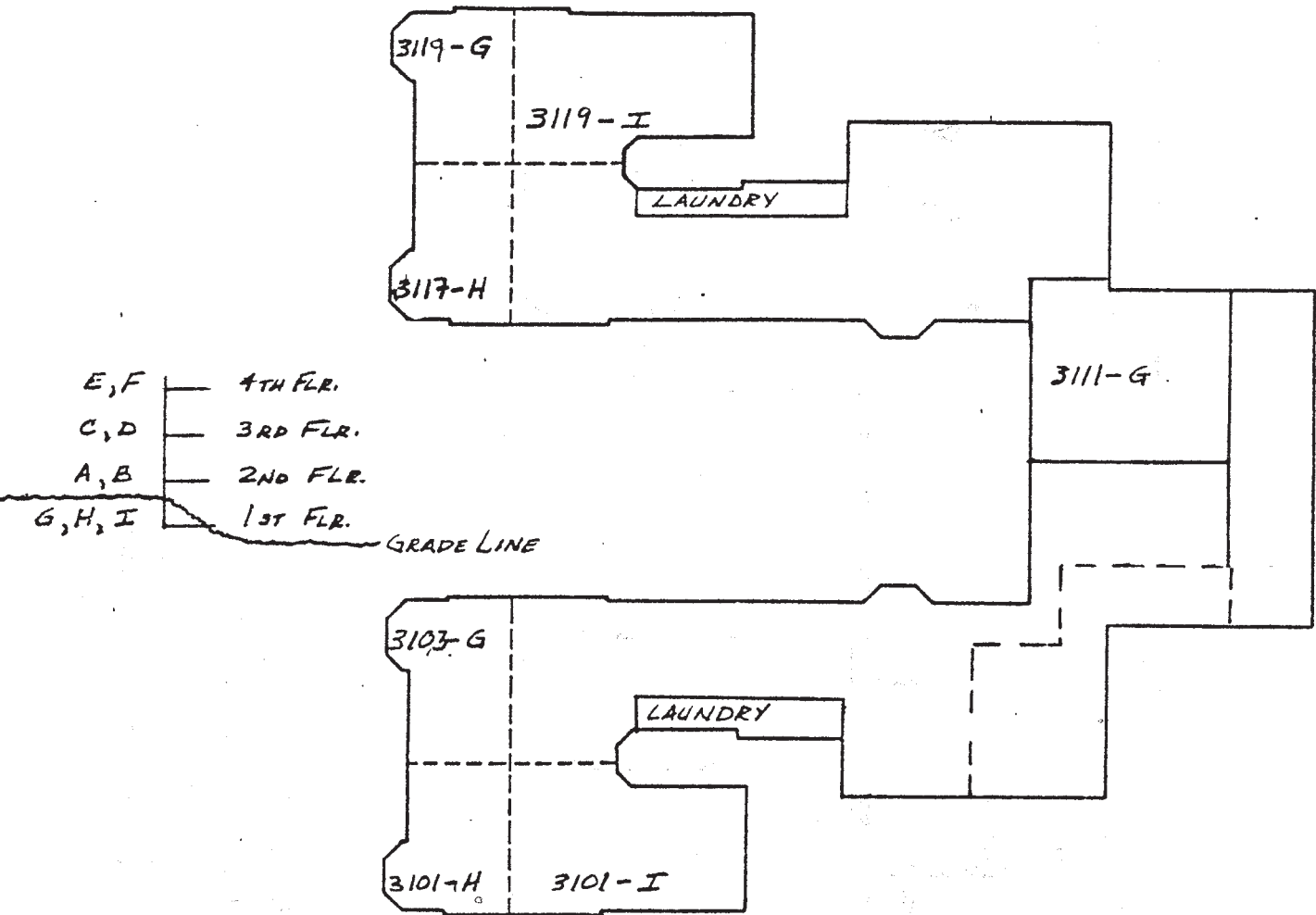

BUCKINGHAM APARTMENTS KEYPLAN

3101 - 3119 N. MERIDIAN ST. INDPLS.



FIRST FLOOR
(BASEMENT LEVEL)

- Unit 5 - Studio Apartments.....700 s.f.
- Unit 6 - Studio Apartments.....818 s.f.

6 Units Total

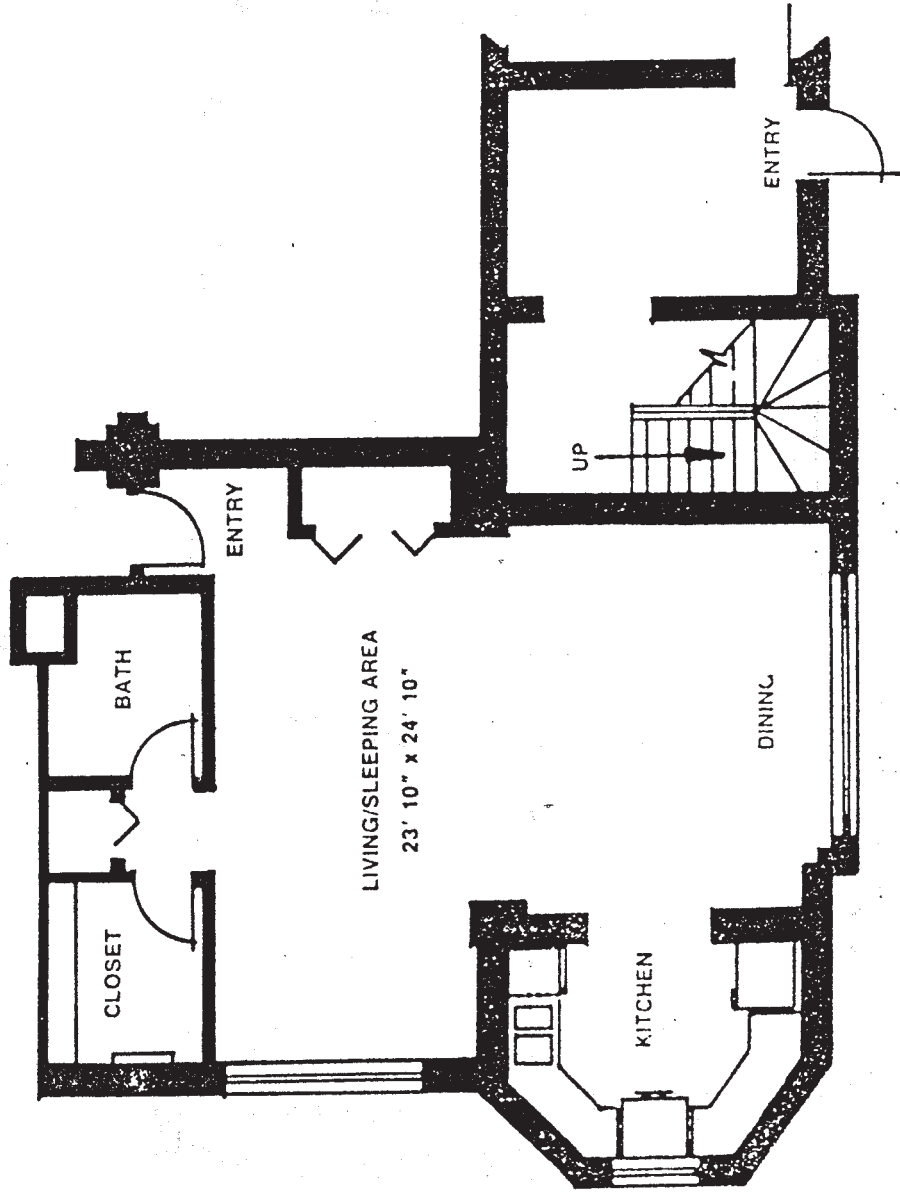

**BUCKINGHAM
STUDIO**

700 sq. ft.

Basement Units H 3101, 3117 North Meridian
Units G 3103, 3119 North Meridian

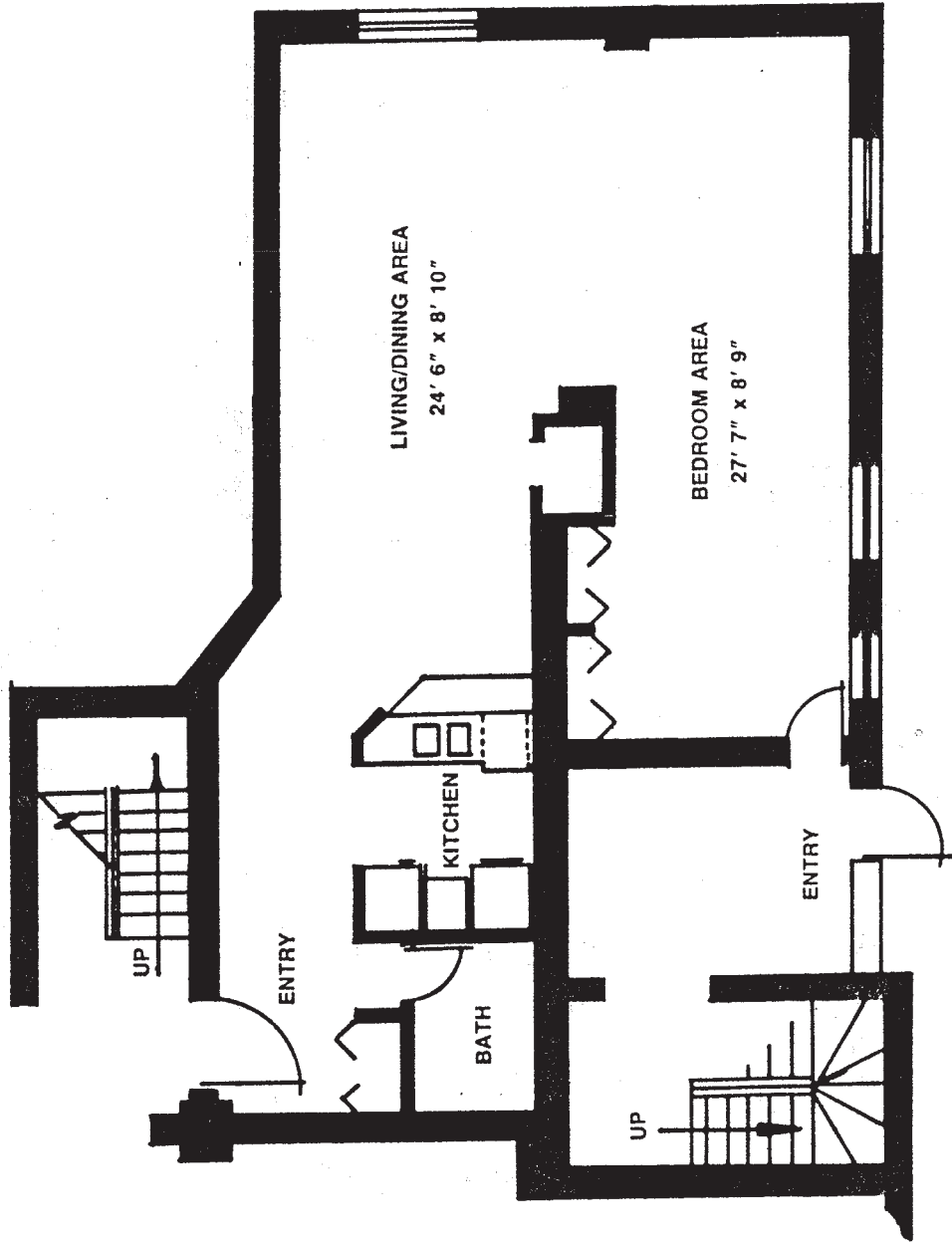

BUCKINGHAM
STUDIO

818 sq. ft.

Basement Units I 3101 and 3119 North Meridian